



**MJ31-280, MJ30-420DW, MJ30-560 &
MJ30-630 CYCLONE HD CUTTER**

**Operator's Manual
and Parts List**



WARNING

Read this instruction manual thoroughly before using your machine and follow all safety precautions.

www.major-equipment.com

Head Office

Major Equipment Intl. Ltd.
Ballyhaunis,
Co. Mayo,
Ireland.

Tel.: +353 (0) 9496 30572
Fax: +353 (0) 9496 30788
Email: info@major-equipment.com

UK Office

Major Equipment Ltd.
Major Industrial Estate,
Middleton Rd.,
Heysham,
Lancs.
LA3 3JJ

Tel.: +44 (0) 1524 850 501
Fax: +44 (0) 1524 850 502
Email: ukinfo@major-equipment.com

NETHERLANDS & GERMANY OFFICE

Major Equipment Intl. Ltd.
Postbus 29,
NL-7700 AA ,
Dedemsvaart,
Nederland.

Tel: +31 (0) 6389 19585
Email: euinfo@major-equipment.com

Web: www.major-equipment.com

@MAJOREQUIPMENT



Disclaimer

While every effort has been made in the production of this manual to ensure that the information contained herein is full and correct, Major assumes no responsibility for errors or omissions.

Major reserves the right to modify the machinery and the technical data contained within the manual without prior notice.

Further to this, Major assumes no liability for any damages which may result from the use of the information contained within this manual.

Contents

Introduction

Thank you	1
Safety Aspects	1
Intended use	1
Register Your Product and Warranty Online	1
Tractor Requirements	2

Safety

Hazards associated with operating Grass Cutting Machinery	2
Operating Safely	3
Workstation	4
Regulations for use of the transmission	4
PTO Shaft Safety	4
Driving Safely on Public Roads	5
Inspections before Use	6
Starting Regulations	6

Product Identification

Machine Serial Numbers	7
Product Specifications	7
	7
EEC certificate of conformity for machines	8
Machine Safety Labels	9
Key to Main Parts	10
Blade Rotation	11
Blade system	12
Drive-line gearboxes	12

Operating the Machine

Attaching machine to the Tractor	13
Transport Position	14
Operating the Machine/Mowing	15
Top Link position (flotation restrictor)	15
Additional adjustments	16
Roller and skid setup	16

Maintenance

Machine storage	17
PTO Shaft Maintenance	17
Transmission Bolts	18
Roller	18
Replacement of wear parts	18
Clearing out a blockage	18
Wing shafts alignment	18
Troubleshooting	19
Lubrication schedule	21

Spare Parts - CYCLONE

MJ30-630 Overview	22
MJ30-560 Overview	22
MJ30-420DW Overview	22
MJ30-630 Body - General Assembly	23
MJ30-630 Body - Linkage and Drivetrain assembly	24
MJ30-560/420DW Body - General Assembly	26
MJ30-560/420DW Body - Linkage and Drivetrain assembly	27
MJ30-560/630 Wing - General assembly and Drivetrain	29
MJ30-420DW Wing Assembly	31
Front Guards assembly (MJ30-560/630/420DW)	33
MJ31-280 General assembly	34
Roller Assembly (All models)	38
PTO shafts	39
MJ30-420DW/560/630 Wing PTO assembly (CYC-WDR01)	39
PTO shaft (607399) 1-3/8”(21)	40
PTO shaft (607400) 1-3/4”(20)	41
PTO shaft (604324)	42
Chain strap	43
MJ30 A-frame buffer (AFB-GA1)	43
Hydraulics setup	44
CAT 2 & 3 Quick hitch linkage setup (MJ30-630-BDGA1)	45
Wheel mounting bracket set (CYC-CW-WGKIT)	46
Wheel kit assembly (CYC-CW-01)	46
Blades	47
JJ.03499 (1.9 3W)	50
MJ40T11 (347.805) (1)	51
MJ40T (347.801) (1.47)	52
MJ40T-S (347.801) (1.47 SHORT)	52
266.207 (1.47 3W)	53
266.207-S (1.47 3W SHORT)	53
266.209 (1.47 4W)	54

Introduction

Thank you

We appreciate having you as a customer and wish you many years of safe and satisfied use of your machine.

Safety Aspects

This manual is an important part of your machine and should remain with the machine when you buy it. Reading your operator's manual will help you and others avoid personal injury or damage to the machine. Information given in this manual will provide the operator with the safest and most effective use of the machine. Only competent and skilled persons who have fully read and understood this operator's manual are allowed to operate this machine.

Sections in your operator's manual are placed in a specific order to help you understand all the safety messages so you can operate this machine safely. You can also use this manual to answer any specific operating or servicing questions.

Your manual contains special messages to bring attention to potential safety concerns, machine damage as well as helpful operating and servicing information. Please read all the information carefully to avoid injury and machine damage. Should any questions arise regarding the information given in this booklet, please contact your local MAJOR dealer or MAJOR.

The operator is solely responsible for the safe use and maintenance of the machine. The machine must only be operated by a competent and skilled person. Setting up and adjustment must only be carried by the operator. Do not let a third party person to adjust or modify the machine in any way.

Intended use

This machine is a grass cutting machine and designed for cutting grass. Moreover, it must only be used with a suitable tractor (see "Product Specifications" section of this booklet) and driven by an adequate drive-line of the tractor PTO. All other use is strictly prohibited. Major will not be held responsible for any loss or damage caused due to a misuse of the machine.

Register Your Product and Warranty Online

To register your product through the Internet, simply go to the Support section on www.major-equipment.com. Completing the information, either online or with the product warranty card, will ensure the customer that their product receives all post sales service and important product information.

This machine is warranted for 12 months. No warranty is given where the machine is being used as a hire machine. Warranty is against faulty workmanship or parts.

Warranty covers parts only. All parts must be returned to the manufacturer. No warranty can be considered unless parts are returned. All replacement parts will be supplied on a chargeable basis until warranty has been accepted.

Tractor Requirements



Attaching the machine to the tractor will influence the stability and manoeuvrability of the tractor. Please consult your tractor manual for limitations on weight and towing ability of the tractor.

It is the operator's responsibility to ensure that the tractor is suitable for the machine. Always consult your tractor's manual for any further information required.

Recommended Horse Power requirements for the particular models are provided in the "Product Specification" section of this booklet. Using excessive power can affect the quality of cut and/or may damage the machine.

Tractors which are not suitable for the operation can sustain damage due to the weight and power requirements of the machine. Always observe the weight of machine provided in the "Product Specification" section of this booklet, compare this with the guidelines from the tractor manual and ensure that the tractor can lift the machine safely.

The machine is designed to be attached by means of a 3 point linkage connection or can be trailed (specific models). The position of the machine can be adjusted by manual or hydraulic top link.

Winged models require at least one hydraulic spool with 1/2" female quick release connection for a single acting ram/rams.

Road light kit requires a 12V 7 pin socket.

Safety

The operator's manual also explains any potential safety hazards whenever necessary in special safety messages that are identified with the word, CAUTION, and the safety-alert symbol .

Hazards associated with operating Grass Cutting Machinery

Shear Hazard

Shear hazards are created when the edges of two objects move toward or next to each other closely enough to cut relatively soft material. This can include the parts of the machine under hydraulic control when operating from transport to mowing position. Note, the wing units are designed to float independently of the centre deck & are free to move within operating limits.

Crush Hazard

Bystanders can be injured when machine is lowered into mowing position. Winged machines have crush points around the hinge areas & between the wing & main body. Always use transport locking bars when not in use (winged models only).

Rotating Blade Hazard

All persons are at risk if they place their hands or feet under the machine when it is raised from the ground when the blades are in motion.

Pinch Hazard

Pinch points are created when two objects move together, with at least one of them moving in a circle. This hazard is common in power transmission devices such as Belt Drives, Gear Drives & Rollers. Ensure all guarding is present.

Wrap Hazard

Any exposed, rotating machine component is a potential wrap point. Injuries usually occur when loose clothing or long hair catch on and wrap around rotating parts such as PTO shafts or Drive shafts on the machine. Ensure all guarding is present.

Free-wheeling parts Hazard

The heavier a revolving part is, the longer it will continue to rotate after power is shut off. This characteristic is called 'free-wheeling.' Blades, and various other components, drive shafts etc., will continue to move after power is shut off - often for several minutes. Injuries occur when:

- Operators shut off equipment, and attempt to clean or adjust a machine before components have completely stopped moving.
- Shear bolt protection device in PTO shaft shears & the mowing parts are still spinning but the primary PTO shaft is stationary. Operator awareness is the key to safety around freewheeling parts. Never raise the machine while the blades are still rotating.

Thrown objects Hazard

Machines throw material as a natural part of doing their job. Foreign objects, such as stones, sticks and other debris, may be taken into this equipment and expelled at tremendous speed. These objects are contained by the sides of the machine and by the rear/front rollers / guards / chain guards / rubber skirts depending on model of your machine. Ensure bystanders are clear from the machine & cannot be hit with debris expelled from the machine. Bystanders or animals in the path of thrown objects could be seriously injured. Never operate machine with decks raised from the ground as this makes the front/rear protection redundant.

Hydraulic Hazard (if applicable)

Hydraulic systems store considerable energy. Careless servicing, adjustment, or replacement of parts can result in serious injury. High pressure blasts of hydraulic oil can injure eyes or other body parts. The following precautions are crucial:

- Make certain the hydraulic pump is turned off.
- Lower attached equipment to the ground.
- Confirm that load pressure is off the system.

A pinhole leak in an hydraulic hose is a serious hazard. A leak may not be visible, and the only sign may be a few drops of fluid. Never inspect hydraulic hoses with your hands, because a fine jet of hydraulic fluid can pierce the skin.

Slips, Trips and Falls Hazard

Slips and falls often result from:

1. Slippery footing on the ground
2. Cluttered steps and work platforms.

The potential for slips and falls can be greatly reduced by using good judgement and practicing good housekeeping on and around equipment.

Noise Hazard

Please note that the machine is normally used outdoors and that the position of the operator is seated in the driving seat of the tractor. It is advisable to consult the prescriptions listed in tractor operator and maintenance manuals.

The acoustic pressure at a distance of 2.6m from the centre of the machine and at a height of 2.0m, with the implement operating in a no load condition can reach 90 dBA. In a loaded condition & a PTO rate of 540 (1000) rpm the value can reach 97dBA. Higher rate of PTO input will result in in higher noise levels. Always wear hearing protection.

Operating Safely

This MAJOR machine is designed to operate at a PTO rate which is stated in the Product Specifications part of this booklet. Ensure tractor PTO output is set at a correct RPM rate. This MAJOR machine must only be used for purposes outlined in the Intended Use section of this booklet. All other use is strictly prohibited.



Users should become thoroughly familiar with the contents of this manual before using, servicing and mounting the implement to the tractor and all other pertinent operations. Never wear jewellery, loose clothing such as ties, scarves, belts, unbuttoned jackets or dungarees with open zips which could become caught up in moving parts.



Always wear approved garments complying with accident prevention provisions such as non-slip shoes, ear muffs, goggles and gauntlets. Wear a jacket with reflecting stickers if the implement is used near public highways.



Consult your retailer, the Labour Health Service or your nearest equivalent authority for the information about the current safety provisions and specific regulations with in order to ensure personal safety.



ALWAYS DISENGAGE PTO, SWITCH OFF THE TRACTOR ENGINE AND ENGAGE THE PARKING BRAKE BEFORE MAKING ADJUSTMENT TO THE MACHINE.



NEVER PLACE LIMBS UNDER THE MACHINE WHILE ROTOR(S) ARE TURNING. ROTOR(S) CAN REMAIN TURNING FOR UP TO 1 MINUTE AFTER DISENGAGING PTO.

Workstation

The operator must remain seated while working the machine. If the machine is a winged unit and the wings need to be raised/lowered the operator must not leave the tractor. Always ensure the PTO has been turned off and the parking brake applied before leaving the tractor cab or carrying out maintenance.



NEVER OPERATE THE HYDRAULICS WITH THE TRACTOR SWITCHED OFF

Regulations for use of the transmission

The transmission to the gearboxes is protected throughout the machine by both PTO shafts and bolt down covers. All guarding should be kept efficient and in good condition. If the condition is poor, the guarding should be renewed before the implement is used.



UNLESS IT IS CORRECTLY PROTECTED THE TRANSMISSION COULD CAUSE DEATH SINCE IT CAN CATCH ON PARTS OF THE BODY OR CLOTHING

Ensure retaining chains are correctly anchored on all PTO shafts, preventing them from turning. Ensure drive line can turn easily within the shield. Keep spline grooves clean and greased so that PTO shaft can connect easily. Besides being described in this booklet, the method by which the PTO shaft is connected to the tractor must be checked out with the instructions in the tractor manufacturer's manual.

PTO Shaft Safety

Maximum PTO input is specified in the Product Specifications section of this booklet. Contact your nearest dealer or a specialised retail outlet if the PTO must be replaced with a longer one, since this must belong to the same power category and possess the same characteristics. An unsuitable PTO could easily break.

The tractor PTO shaft length may be altered to suit the individual tractor model. When the machine is in operation, the PTO shaft should have a minimum 1/3 engagement as shown in the diagrams. After the machine has been hitched to the tractor, it should be checked in various positions that the drive line is the correct length. If the PTO is too short and tends to slip out of place, it must be replaced with a longer one.

If the PTO shaft is too long, it should be shortened in the following way:

- Set the machine at a minimum distance from the tractor, then brake the tractor and switch off the engine.
- Separate the two halves of the PTO. Insert the female part into the tractor PTO and the male part into the machine PTO, checking that the position is correct by means of the fixing pins.
- Line up the two halves of the PTO together, keeping them parallel.
- Using a felt tip pen, match mark the place where the two halves must be shortened as shown.
- First cut shield "1" and use part "2" as a reference to cut the splined shaft.
- Proceed in the same way for the second half.
- Trim and chamfer the two cut ends of the PTO and clean off all swarf and shavings.
- Grease the two profiles and join the two halves of the PTO together.
- Mount the PTO shaft and check that its length is correct as before.

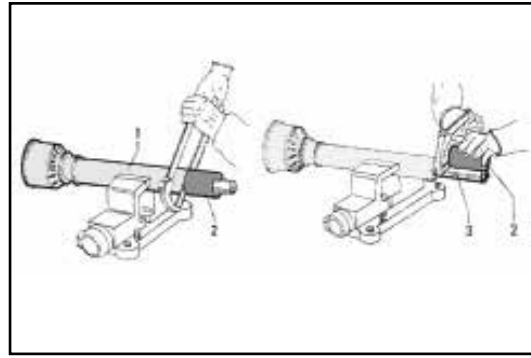
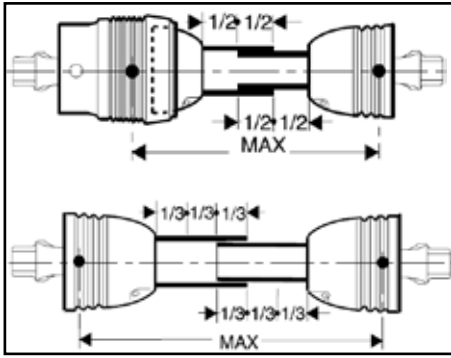

Driving Safely on Public Roads

Check the local Highway Code regulations before driving the tractor on public highways with an implement attached. Check the reflectors, hazard flashers and/or projecting load indicators are installed when required and efficient. These indicators must be installed correctly and easily seen by the drivers of other vehicles.

Bystanders must not be allowed to lean against or climb onto the machine during transport or while working. Do not allow bystanders to ride on the machine.



Maximum transport speed of the implement is limited to 25-30km/h depending on the model of the machine (observe safety labels on the machine).

Trailed Machines only

The shaft must not reach the end of the tube or project from this. Ensure the PTO does not bottom when turning

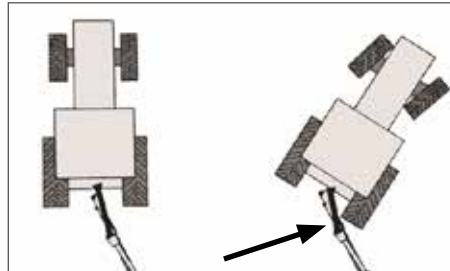

General safety instructions

Precautions to be taken while working with the machine:

1. Do not operate the machine when you are tired or under the influence of alcohol or any other intoxicant;
2. Before starting mowing, make sure that the area is clear of people or animals.
3. Before starting adjusting the machine, it is mandatory to disconnect the PTO, to turn off the engine of the tractor, apply handbrake and wait for the turning parts to become still and placed on the ground.
4. It is mandatory to read all the safety requirements and the operator's manual of the machine.
5. If you are not sure how to use the machine, please contact the manufacturer or the dealer.

Inspections before Use



Always disengage PTO, Switch off tractor engine and engage the parking brake before making adjustments to the machine.

1. With the whole machine as level as possible, check the oil level in all gearboxes. Top up if required through the oil filler plug. The correct level is at the oil level plug.
2. Grease all lubrication points as outlined in the Maintenance section of this booklet.
3. Check parts for wear.
4. Check the blade mounting bolts are tight.
5. Ensure the gearbox shaft nuts are tight and retained in place by split pin.
6. Check tightness of all nuts, bolts and pins.
7. Ensure safety guards and flaps are in place at all times where fitted. If these become worn or missing, replace them immediately with new ones.
8. Due to the corrosive nature of grass when cut, wash down the machine when finished mowing, especially when the machine is being stored for a long period of time.

Starting Regulations



Always check that any imminently dangerous conditions have been eliminated before using the machine. Ensure all guarding is present & the operator is fully aware of the operations of the machine.



Always ensure the pins lock the PTO shaft yoke ends onto the spline shafts on both the tractor and the implement. An unlocked shaft could slip out of position, causing notable mechanical damage and serious injury to both operator and bystanders.

Product Identification

Machine Serial Numbers

If you need to contact MAJOR or your MAJOR dealer for information on servicing or spare parts, always provide the product model and serial numbers. Model and Serial number can be found on the Serial Plate located on the machine.

We suggest that you record your machine details below:

Model No: _____

Serial No: _____

Date of Purchase: _____

Dealer Name: _____

Dealer Telephone: _____

MAJOR EQUIPMENT INTL. LTD. BALLYHAUNIS, CO. MAYO, IRELAND TEL: +353 (0) 9496 30572 EMAIL: info@major-equipment.com		
MAJOR EQUIPMENT LTD (UK) MAJOR IND. ESTATE, HEYSHAM, LANCS, LA3 3JJ, UK TEL: +44 (0) 1524 850501 EMAIL: ukinfo@major-equipment.com	Serial Number/Seriennummer <input type="text"/>	
MAJOR EQUIPMENT INTL LTD POSTBUS 29, NL-7700 AA DEDEMSVAART, NEDERLAND TEL: + 31 (0) 6389 19585 EMAIL: euinfo@major-equipment.com	Model/Modell <input type="text"/>	
	Year of manufacture/Baujahr <input type="text"/>	

Product Specifications

Model	MJ30-630	MJ30-560	MJ30-420DW	MJ31-280
Overall Width	21' 4½"	5.82m (19' 1")	4.43m (14' 6")	3.00m (9' 9")
Cut Width	20' 8"	5.6m (18' 4.5")	4.22m (13'10")	2.79m (9' 2")
Transport Width	9' 1¾"	2.54m (8' 4")	2.54m (8' 4")	3.00m (9' 9")
No. of Blades	36	32	24	16
No. of Rotors	9	8	6	4
Power (HP)	140-190	100-150	100-150	60-110
PTO (rpm)	1000	1000	1000	540
Blade Speed	58m/s 11400FPM	58m/s 11400FPM	58m/s 11400FPM	58m/s 11400FPM
Cutting Height	2" to 6¾"	2" to 6¾"	2" to 6¾"	1" to 9¾"
Weight	1900 kg 4190 lbs.	1700 kg 3750 lbs	1400 kg 3090 lbs	945 kg 2085 lbs

EEC certificate of conformity for machines

(conforming to Directive 2006/42/EC)

Name of Manufacturer: Major Equipment Ltd
Address: Coolnaha, Ballyhaunis, Co. Mayo, Rep of Ireland

Tel. +353949630572
Fax +353949630788

declares in sole responsibility that the product:

Machine description and function: Rotary mower with vertical axes cutting heads which cuts grass so it can be subsequently picked up.

Model: Cyclone heavy duty mower (MJ30 & MJ31)

Type: _____

Serial number: _____

Technical file compiled by: Alex Kolchanov (c/o Major Equipment Ltd)

- **THE SUPPLY OF MACHINERY (SAFETY) REGULATIONS 2008.**
- **S.I. No. 299 of 2007**, Safety, Health and Welfare at Work (General Application) Regulations 2007 (Ireland).
- **Health & Safety at Work, etc. Act 1974 (c.37) (UK).**
- **EN ISO 14121-1: 2007** 'Safety of machinery. Principles for risk assessment'.
- **EN 745** - Agricultural Machinery - Rotary Mowers and Flail Mowers - Safety.
- **EN ISO 13857** - Safety of machinery: Safety distances to prevent hazard zones being reached by upper and lower limbs.

I hereby certify on behalf of Major Equipment Int. Ltd., that this machine when properly installed and operated correctly, complies with all the essential Health & Safety requirements of all legislation referred to above.

Signed: 
Date: 14/11/2018
Name: John Murphy
Position: Managing Director

Place: Coolnaha, Ballyhaunis, Co. Mayo, Rep of Ireland

Machine Safety Labels

The machine safety labels shown in this section are placed in important areas on your machine to draw attention to potential safety hazards.

On your machine safety labels, the words DANGER, WARNING, and CAUTION are used with this safety alert symbol. DANGER identifies the most serious hazards.

To prevent Serious Injury or Death

- Avoid unsafe operation or maintenance.
- Do not operate or work on this machine without reading and understanding the operator's manual.
- If manual is lost, contact your nearest dealer for a new manual.



To avoid injury, read the manual

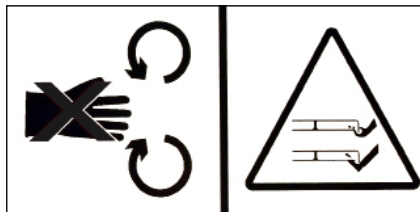

Rotating blade hazard



PTO entanglement hazard - keep clear of PTO drives.

WARNING



DO NOT GO NEAR LEAKS

- High pressure oil easily punctures skin causing serious injury, gangrene or death.
- If injured, seek emergency medical help. Immediate surgery is required to remove oil.
- Do not use finger or skin to check for leaks.
- Lower load or relieve hydraulic pressure before loosening fittings.

High oil pressure hazard

ATTENTION!!

CHECK TIGHTNESS OF TRANSMISSION BOLTS AT EVERY SERVICE.

Check tightness of the transmission bolts

PTO TUBES MUST BE GREASED EVERY 10 HOURS

Grease PTO tubes

CHECK TIGHTNESS OF TRANSMISSION BOLTS AFTER FIRST 8 HOURS OF WORK

Check bolts



Grease points

<p>MAX PTO INPUT 540 RPM</p> <p>© MAX. DREHZAHL 540 U/MIN © MAX. TOERENTAL 540 TPM © MAX. PRISE DE FORCE 540 TOURS/MIN</p>	<p>MAX PTO INPUT 1000 RPM</p> <p>© MAX. DREHZAHL 1000 U/MIN © MAX. TOERENTAL 1000 TPM © MAX. PRISE DE FORCE 1000 TOURS/MIN</p>
---	---

Maximum PTO input

ATTENTION!

Do not engage drive while in transport position

Do not engage drive while in transport position



Moving parts

ATTENTION

DURING THE OPERATION THE FRONT OF THE MACHINE MUST BE SET HIGHER THAN THE REAR

Machine setup

Key to Main Parts

Please see page 42 for CAT 2 & 3 Quick hitch setup

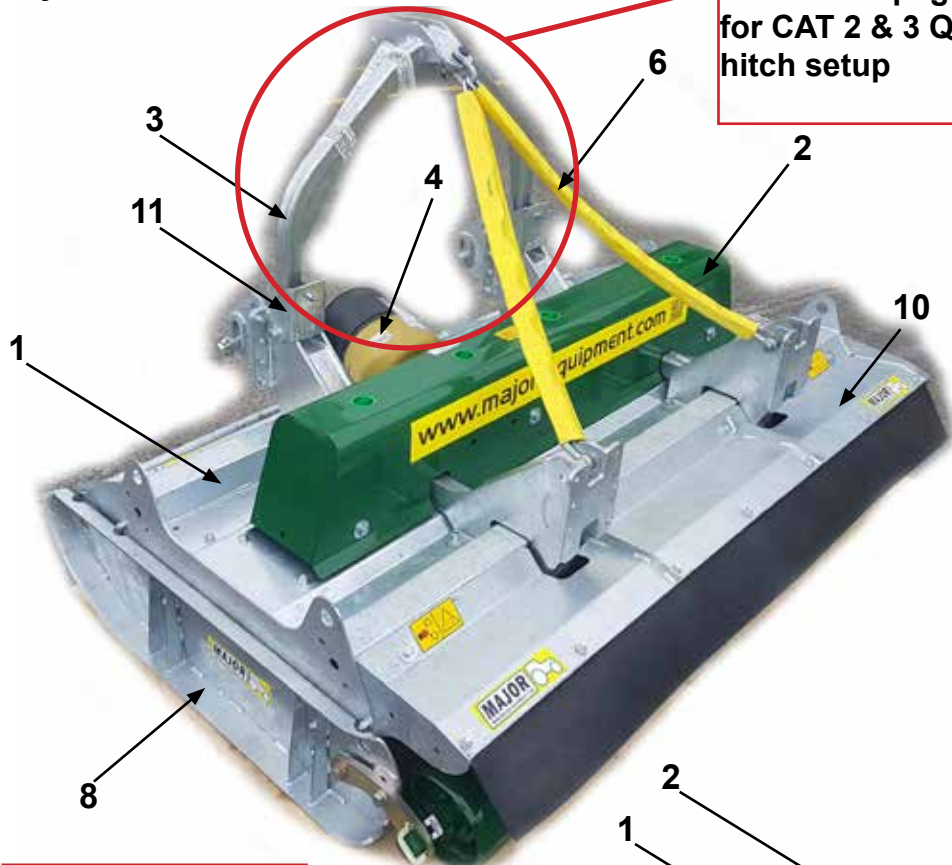

Please see page 42 for CAT 2 & 3 Quick hitch setup

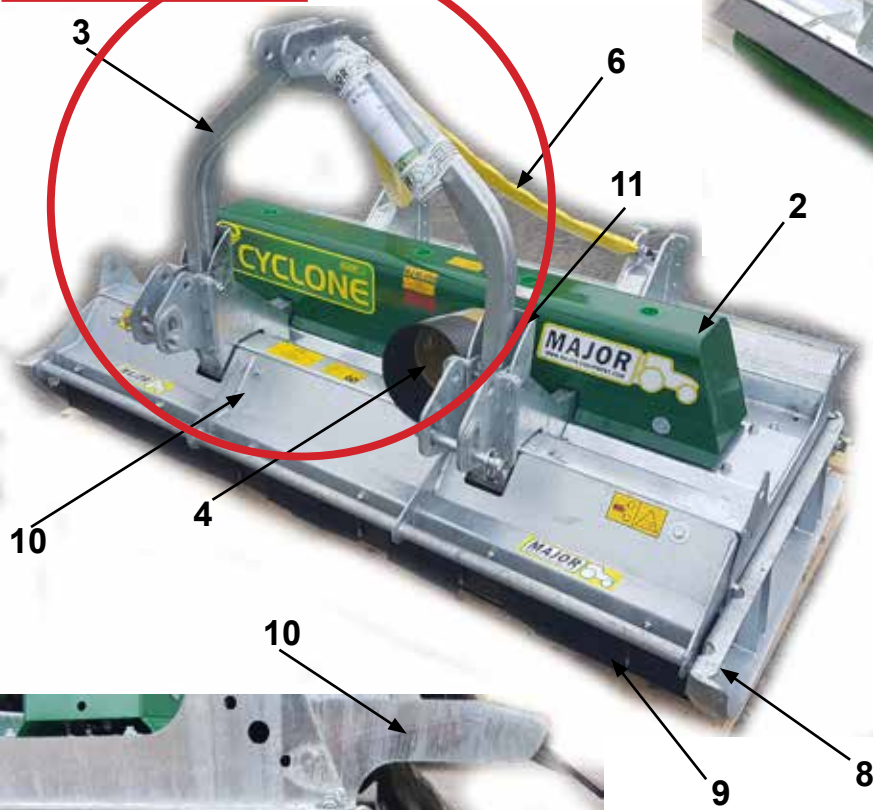

1	Body
2	Transmission cover
3	A-Frame (Please see page 42 for CAT 2 & 3 Quick hitch setup)
4	Gearbox PTO cover
5	Rear roller
6	Strap/Chain
7	Roller height indicator
8	Skid
9	Rubber skirt
10	Guards
11	A-Frame buffer stop
12	Wing
13	Blade

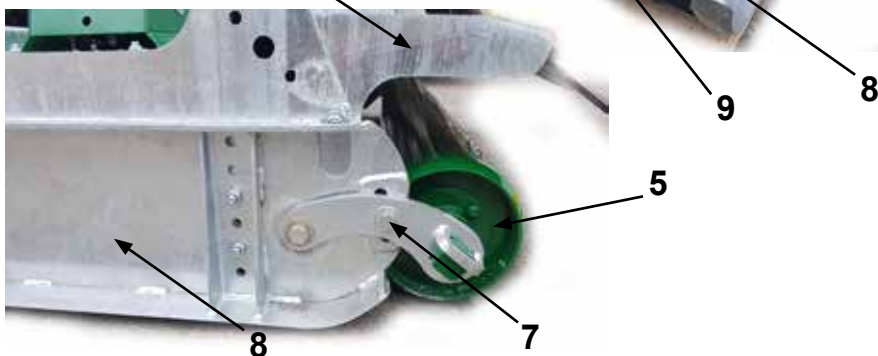

Blade Rotation

Blade rotation viewed from underside

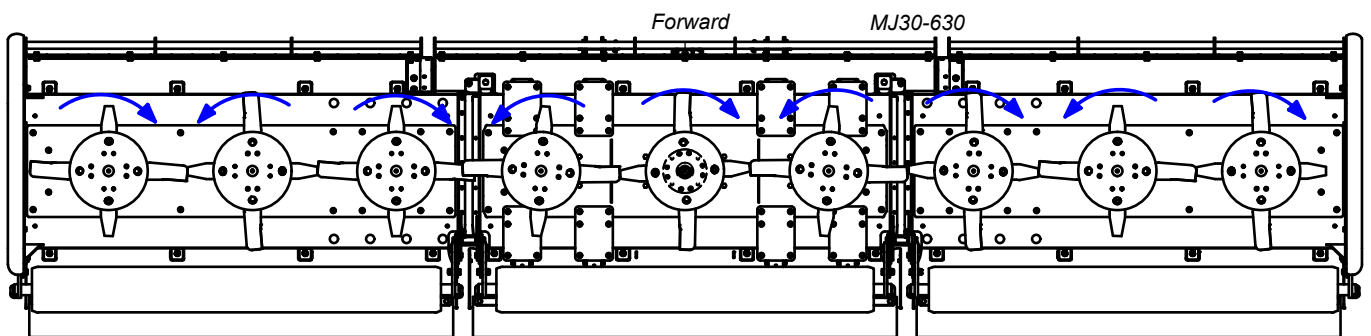
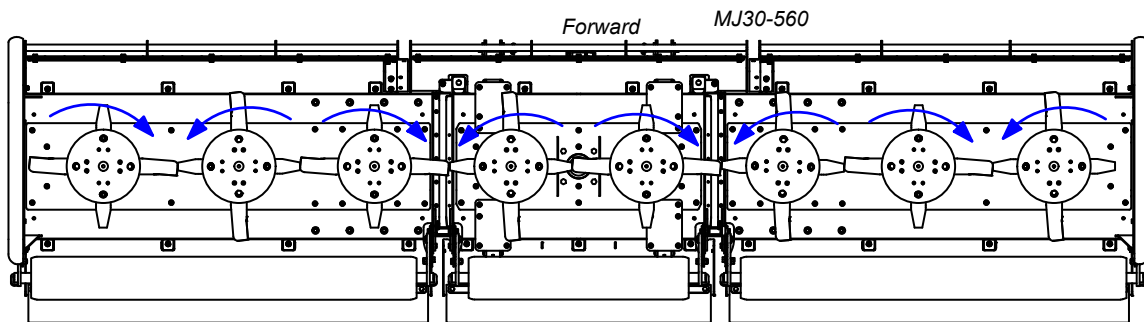
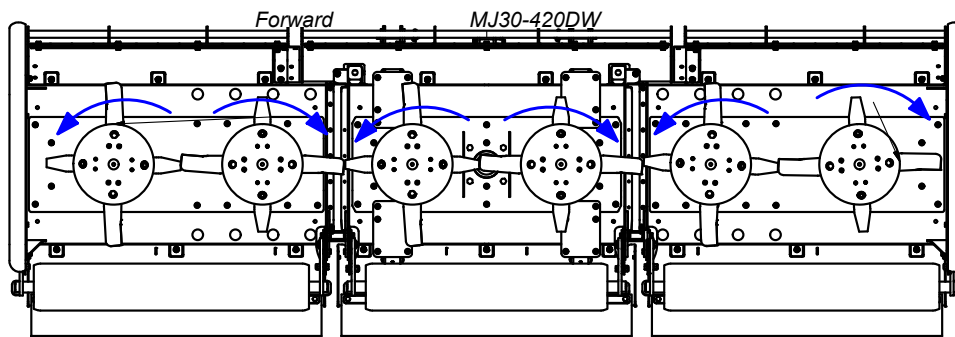
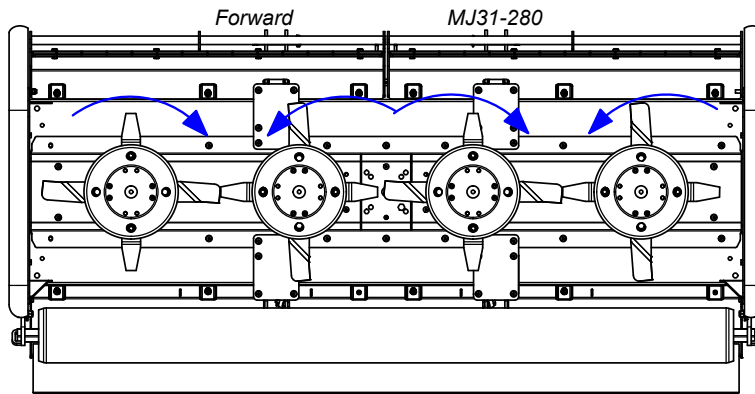

Blade system

Full breakdown of the blade assembly is provided in the Spare Parts section of this booklet

1 Blade mount	7 Blade pivot bolt
2 Gearbox output shaft	8 Blade pivot bush
3 Gearbox split pin	9 Blade
4 Blade back	10 Undersole disk
5 Blade back bolt	11 Overlap Blade
6 Blade back spacer	

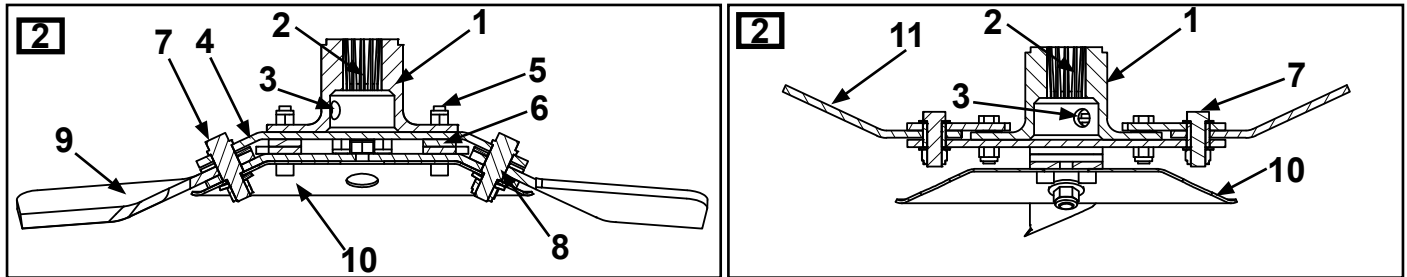

Drive-line gearboxes

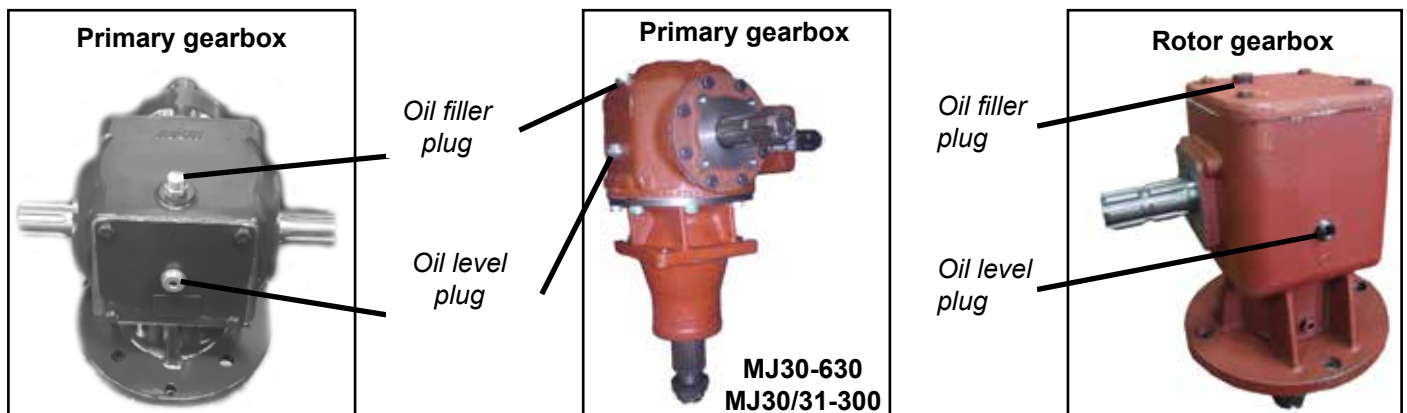

Operating the Machine

Attaching machine to the Tractor



ALWAYS OPERATE ON LEVEL GROUND WHEN HITCHING/UNHITCHING THE IMPLEMENT. THIS WILL PREVENT DANGEROUS MOVEMENT. NEVER ALLOW ANYONE TO STAND BETWEEN THE TRACTOR AND THE MACHINE.

Three Point Linkage Models

1. Adjust both lift arms of the tractor until they are level in relation to each other.
2. Hitch the lower linkage arms to the Machine and connect the top link and PTO shaft. Ensure that the locking pins are secure.
3. With the Machine lowered in its operating position, adjust the top link until the strap is slack, allowing the Machine to produce a uniform finish in varying ground conditions.
4. Check the PTO shaft for length as described previously. Connect the PTO shaft. Ensure PTO check chains are anchored to prevent PTO guarding from rotating.
5. Connect the hydraulic hoses to the appropriate connections (selected models only).

Trailed Models

1. Adjust the tractor hitch pin so that the hitch pin is approximately 400 mm (16") from the end of the tractor PTO shaft.
2. Adjust the machine hitch eye to suit the tractor drawbar height paying particular attention to keep both height adjusting bolts as far as possible on the adjusting bracket. Careful adjustment of the hitch eye height at this stage is necessary in order to allow the machine to function safely and correctly.
3. Connect the machine to the tractor. Ensure no one is standing between the tractor and the Machine.
4. Check the PTO shaft for length as described previously. Connect the PTO shaft. Ensure PTO check chains are anchored to prevent PTO guarding from rotating.
5. Connect the hydraulic hoses to the appropriate connections (selected models only).

Transport Position



Before raising the machine wait until the transmission and the blades are completely still.
During the transport of the machine it is recommended that the PTO shaft is disconnected.

1. Check machine is hitched to the tractor as described. Ensure the tractor parking brake is applied
2. Ensure moving parts become still then transform the machine into transport position by hydraulic control
3. During the transport and any time the machine shall be raised, the raising device shall be adjusted to assure that the machine is at least 250mm over the ground.

Transport Position (Winged models only)



The transport locking bars, transport pin and axle ram stopper should always be slotted into place while transporting the machine. Doing this removes pressure from the hydraulic system. Failure to use the safety equipment can cause mechanical as well as physical damage.



Transport Speed of Trailed models should not exceed 25 km/h.

Top Link Position



Operating the Machine/Mowing



Never place limbs under the machine while rotors are turning. Rotors can remain turning for up to 1 minute after disengaging PTO.



While operating this machine the PTO input rate should not exceed the RPM stated in the Product Specifications section of this booklet. Always operate on level ground when connecting/disconnecting the implement. This will prevent dangerous movement.



Never allow anyone to stand between the tractor and the machine. Ensure the machine is attached correctly to the tractor as previously described. Always start up the tractor PTO at a low RPM. Build up to operating speed, select a suitable forward gear & proceed to cut grass.

1. Hitch the machine as outlined in the previous section. Ensure bystanders are clear from the machine & cannot be hit with debris expelled from the machine.
2. Locate the Parking Jack on its side under the PTO shaft on the stub provided (Trailed models only)
3. Ensure the PTO stand is flipped down. (Trailed models only)
4. Check PTO shaft is fully engaged on tractor PTO splines.
5. Raise the machine by hydraulic control. (Trailed models only)
6. Flip back axle and drawbar ram stoppers. (Trailed models only)
7. Lower the machine by hydraulic control to the ground or use tractor linkage controls.
8. After clearing the vicinity of bystanders, relocate the Wing Transport Locking Bars. Lower the wings by hydraulic control. Ensure hydraulic ram is fully closed. (Winged mowers only).
9. Start up the tractor PTO at a low RPM.
10. Build up to operating speed, select a suitable forward gear & proceed to cut grass.

Top Link position (flotation restrictor)

To set the top links into mowing position lower the wings on level ground. Adjust the top link so the pin (1) is located in the middle of the slot (2). Lock the position by tightening the lock nut (3).

Top links limit the wing lift and prevent damage to wing PTO shafts and gearboxes.

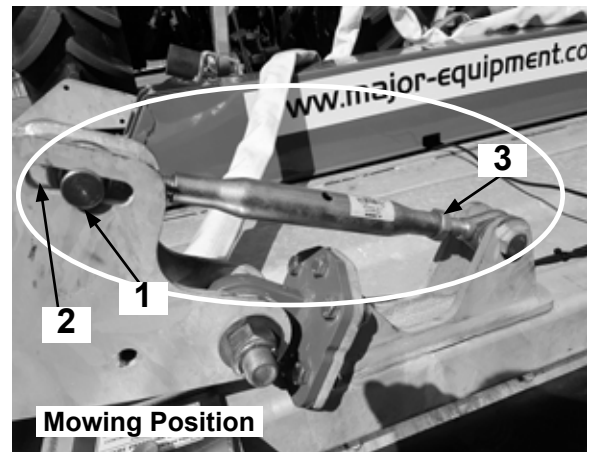

Additional adjustments

Parking stand leg must be fitted and secured with the pin before detaching machine from the tractor.

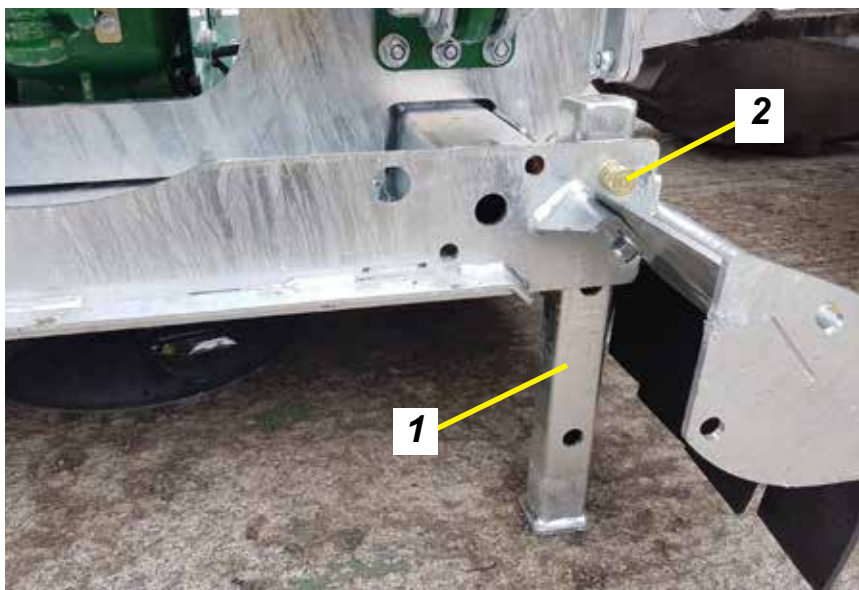

- | | |
|---|--------------------------|
| 1 | <i>Parking stand</i> |
| 2 | <i>Parking stand pin</i> |

Roller and skid setup



Always perform the adjustments on a level ground with the PTO disconnected.
Roller and skids must not become detached from the machine.

1. Skid height can be changed by locating the skid in different skid adjustment slots.
2. Roller position must be adjusted to suit the working conditions.
3. The front of the machine should always be higher than the back.
4. Set the wing hydraulics In float when cutting.
5. At the turn-row lock wing rams and lift the machine. After the turn is complete drop the machine down and put the wing hydraulics in float again.

NOTE: For cutting crops over 2 foot high:

- Set the wings down and the centre body on level ground.
- Lift the tractors arms about 3 to 4 inches upwards so the front of the deck is at a higher pitch than the rear.

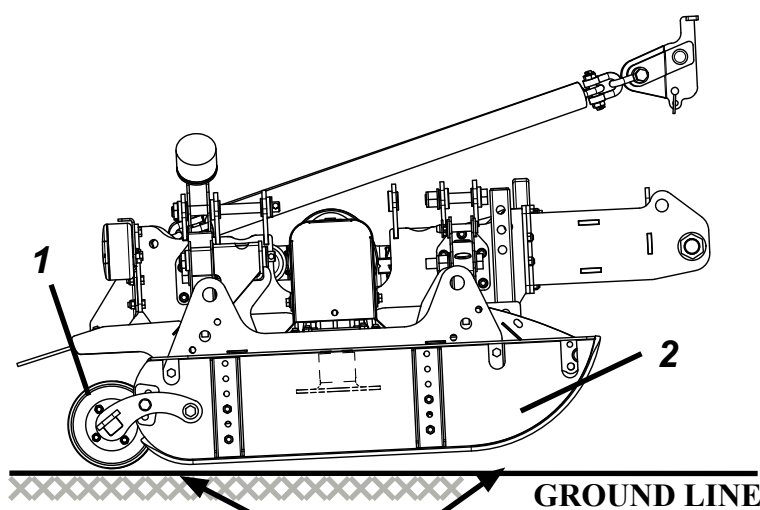

NOTE:
Front of the machine
must be at a higher
pitch than the rear.

- | | |
|---|---------------------------------------|
| 1 | <i>Roller</i> |
| 2 | <i>Skid</i> |
| 3 | <i>Skid adjustment slots</i> |
| 4 | <i>Roller height adjustment slots</i> |
| 5 | <i>Roller pivot arm</i> |

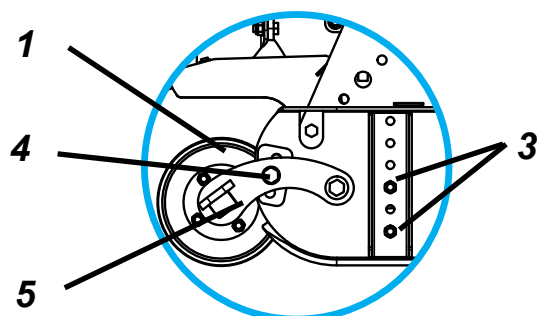

Maintenance

In order to keep your Major machine in a good working order it is necessary to conduct maintenance on a regular basis. Only competent and skilled persons who have fully read and understood this operator's manual are allowed to carry out maintenance on this machine. It is important to replace worn parts immediately with genuine Major spare parts. These parts are manufactured to the same specification as the machine and will provide the best result. Genuine Major spares can be obtained from MAJOR or your local MAJOR dealer.

All maintenance checks and operations must be carried on a firm level ground. The machine must always be disconnected from the tractor before any cleaning, lubricating and servicing operations can be carried out. If works must be carried out under the machine, ensure that the props, jacks, stands, hoists or cranes are capable of supporting the machine securely.

If emergency operations are required whilst the machine is connected to the tractor, switch off the engine of the tractor, remove the key from the ignition, engage the parking brake and disengage the PTO. An example of such emergency situation is the complete blockage of the machine in the field. To clear out the blockage follow the safety steps described above and clear out the blockage. Ensure there are no ropes, twines or wires wrapped around the rotors.

Machine storage

To prolong the life of your machine it is recommended to store it in a dry environment. Prior to parking the machine for storage, wash the machine thoroughly, especially underneath, and ensure that there is no grass or debris left on the machine. Lubricate all pivot points with EP2 type grease. Check for oil leaks and fix these if required. Any parts of the machine with damaged paint/galvanised surface must be painted.

PTO Shaft Maintenance

Guard Removal and Yoke End Greasing

1. Prise back locking tabs
2. Pull back PTO Guard
3. Grease points as shown
4. Push Guard into position
5. Click into place
6. Tie check chain

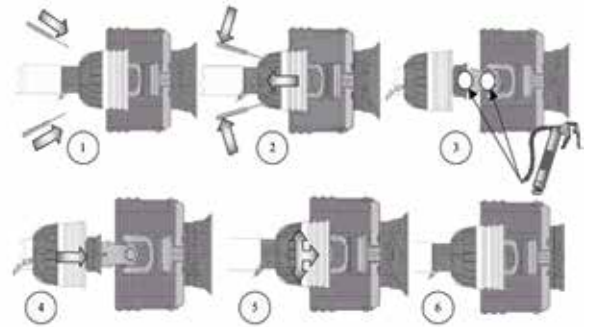

PTO Greasing Intervals

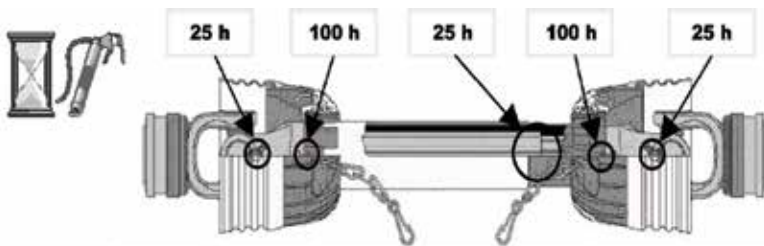

Shearbolt Replacement (if applicable)

1. Slide yoke shield back.
2. Drive out sheared bolt with hammer and punch.
3. Align holes and install new shear bolt. (Use only genuine MAJOR replacement shear bolts)
4. Slide yoke shield securely in place



Always fit PTO shaft with the shearbolt/slip-clutch end connected to the machine as directed on the PTO guarding.

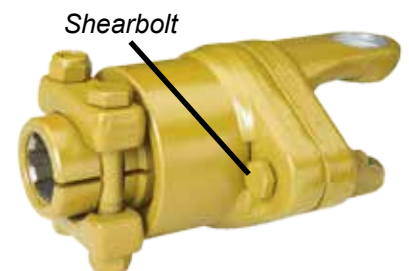

Transmission Bolts

All nuts and bolts in the transmission including Rubber couplings, Star Drives, PTO Shafts and Gearboxes should be checked for tightness after mowing at the following intervals:

1st 50 Acres

1st 100 Acres

1st 250 Acres

And every 250 acres thereafter.

Roller

Check the condition of the rollerend (stub axle) at the end of every season. Roller shaft (stub) must be able to rotate freely and without excessive play. If necessary, remove the roller assembly and adjust the tightness of the bearings.

Replacement of wear parts

Blades, blade backs, blade bushing, blade bolts and nuts must be checked on a regular basis for wear and deflection. MAJOR recommends to visually check the blade assemblies every 40 hours of operation. This interval may change depending on the operational conditions.

Replace any damaged or worn parts immediately, failure to do so can result in blade breakages and can cause damage to the equipment or injuries to the operator and others nearby.

Blunt blades must be sharpened or replaced, failure to do so will result in a poor quality cut and excessive use of power from your tractor.



ENSURE BLADE ROTATION AND TIMING IS CORRECT AFTER SERVICING TRANSMISSION.



Pay attention when servicing or detaching components from the machine. Subassemblies and parts e.g. blade assemblies, gearboxes, rollers, guards, skids, wheels etc. can weigh up to 100 kilograms individually and must be supported adequately before fully detaching from the machine.

Clearing out a blockage



Always wear appropriate PPE when clearing out blockages.

If blockage of blades occurs proceed as follows:

1. Set the machine into transport position (including the top links);
2. Park the tractor on level ground, switch off the engine and remove the key from the ignition;
3. Apply a handbrake and disconnect the PTO shaft;
4. Using a pressure washer clear out the excess material built up around the blades. If the pressure washer is not available use your hand to remove the grass from around the blades, bearing in mind that there might be wires wrapped up around the rotors.

Wing shafts alignment

Ensure that after servicing the transmission, the wing pto shaft yokes are correctly aligned as shown in the diagram below – winged models only. If the shaft journals are fitted incorrectly the damage will only occur when the wings are raised into transport position.

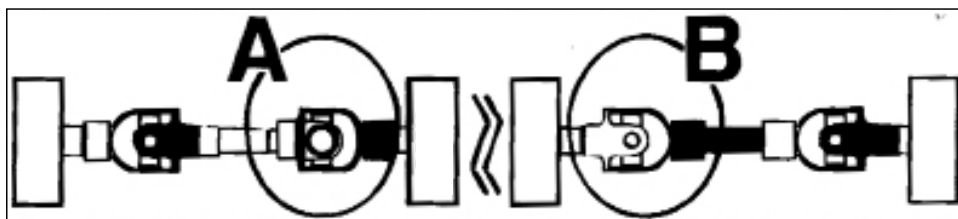

Troubleshooting

Fault	Cause	Remedy	
Machine is getting blocked	Material too high or too much material	Reduce the ground speed but maintain required rpm from the PTO input	
	Grass is too wet	Stop and wait until grass is dried	
	Worn or dull blades	Sharpen or replace blades	
Leaves a streak of uncut or partially cut grass	Blades dull or bent	Sharpen or replace blades	
	Carrier RPM too low	Use correct PTO speed	
	Field conditions are so wet that the tractor tyre is pushing grass into mud	Too wet to mow. Stop operation and wait until grass is drier	
	Ground speed too fast	Reduce ground speed by shifting to a lower gear	
	Possible build-up materials under mower	Clean mower	
	Blades mounted incorrectly (cutting edge against direction rotation)	Change blades so that cutting edge is facing correct rotation.	
Material discharges from mower unevenly; bunches of material along with swath	Material too high and/or too much material	Reduce ground speed but maintain 540RPM or 1000RPM (model dependant) at tractor PTO or make two passes over material. Raise mower for the first pass and lower to desired height for the second and cut a 90 degree angle to first pass.	
Gearbox overheating	Low on lubricant	Fill to proper level	
	Improper type lubricant	Replace with proper lubricant	
	Excessive grass / debris build-up around gearbox	Remove grass, etc from machine	
Blade/bullets is scalping ground	Mower too low	Raise mower-reset wheels	
	Field is ridged	Cut field at a different angle	
	Field is too wet	Stop and wait until it is dried	
Mower will not cut.	Shear bolt sheared	Install new shear bolt	
Blades/bullets wear too fast	Cutting in sandy conditions	Increase cutting height	
	Cutting in rocky conditions	Increase cutting height	
	Blades hitting ground	Increase cutting height	
Mower seems to require excessive power	Advancing into grass too rapidly	Reduce forward travel speed	
	Hitting ground	Raise mower and reset wheels	
	Worn or dull blades	Sharpen or replace blades	
	Tractor not large enough	Use larger horsepower tractor	
Excessive vibration	Check gearbox bolts	Tighten if loose	
	Check for loose nuts on blades	Tighten if loose	
	Blade broken	Replace blades, in set	
	New blade or bolts matched with worn blade or bolts	Replace blades or bolts in sets	
	Drivelines not phased correctly. Implement and tractor yokes must be in line	Phase the driveline. Replace if necessary	
Noisy machine	Worn bearing	Replace bearings	
	Low oil in gearbox	Check level and add oil	
	Loose Parts	Check all bolts are fully tightened	
	Wrong PTO rpm rate	Check PTO rate & adjust as necessary	
	Rotors bent / broken	Replace bent or missing blades	
	Bent PTO shaft		Check PTO shafts are aligned correctly
			Check output shaft on gearboxes are not bent
		Check driveline between gearboxes is aligned.	

Gearbox leaking	Damaged oil seal	Replace seal
	Bent shaft	Replace oil seal and shaft
	Shaft rough in oil seal area	Replace or repair shaft
	Oil seal installed incorrectly	Replace seal
	Oil seal not sealing in the housing	Replace seal or use a sealant on outside diameter of seal
	Oil level too high	Drain oil to proper level
	Hole in gearbox	Replace the gearbox
	Gasket damaged	Replace gasket
	Bolts loose	Tighten bolts

Lubrication schedule

Use EP2 type grease or equivalent.

Use oil which conforms to 85W/140 standards.

	Grease points	Initially	25 hours	40 hours	80 hours	400 hours
All PTO Shaft Yoke Ends		●	●			
PTO tubes		●	●			
Wing eye pivot	0/4	●		●		
Hydraulic Ram	0/2	●		●		
Roller stub axles *	2/6	●		●		
Castor wheel pivot	0/4				●	
Castor wheel axle	0/4				●	
Check oil levels in the gearboxes					●	
Replace oil in gearboxes						●

* - Grease roller stub axles daily if working in row crops or dusty conditions

Spare Parts - CYCLONE

MJ30-560 (HR20617+)

MJ30-630

MJ30-420DW

MJ30-630 Overview

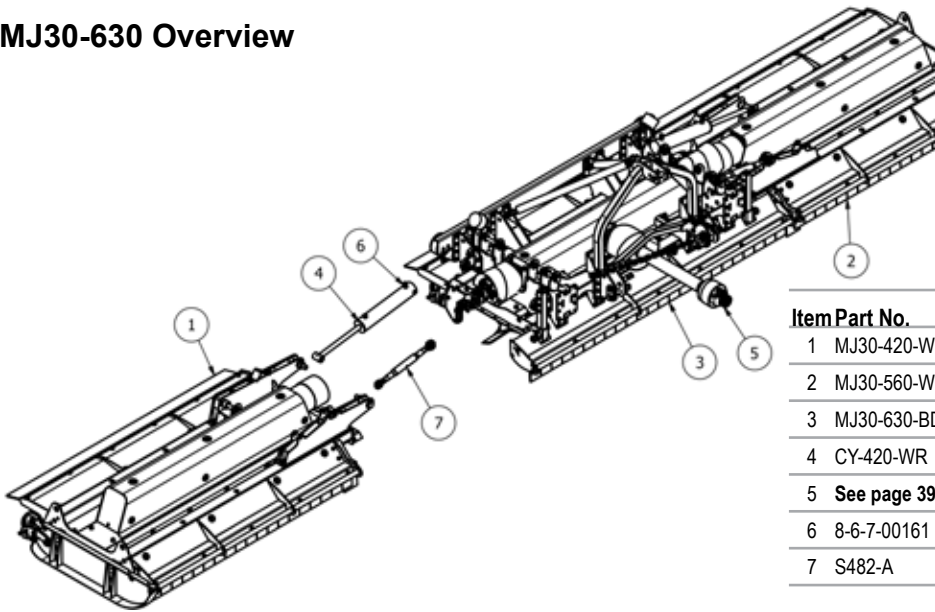

Item	Part No.	Description	Qty
1	MJ30-420-WGGA1	420 CYCLONE WING ASSY	1
2	MJ30-560-WGGA1LH	560 CYCLONE WING (LH)	1
3	MJ30-630-BDGA1	630 CYCLONE BODY ASSY	1
4	CY-420-WR	CYCLONE WING RAM	2
5	See page 39	PTO SHAFT	1
6	8-6-7-00161	3/8" BREATHER PLUG (68085600)	2
7	S482-A	CAT 1-2 TOP LINK	2

MJ30-560 Overview

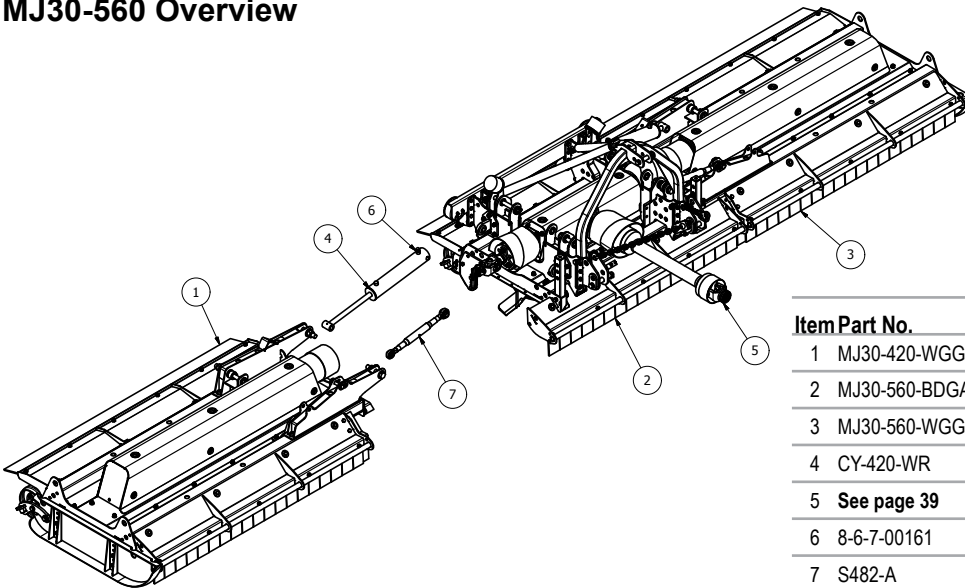

Item	Part No.	Description	Qty
1	MJ30-420-WGGA1	420 CYCLONE WING ASSY	1
2	MJ30-560-BDGA1	560 CYCLONE BODY ASSY	1
3	MJ30-560-WGGA1LH	560 CYCLONE WING (LH)	1
4	CY-420-WR	CYCLONE WING RAM	2
5	See page 39	PTO SHAFT	1
6	8-6-7-00161	3/8" BREATHER PLUG (68085600)	2
7	S482-A	CAT 1-2 TOP LINK	2

MJ30-420DW Overview

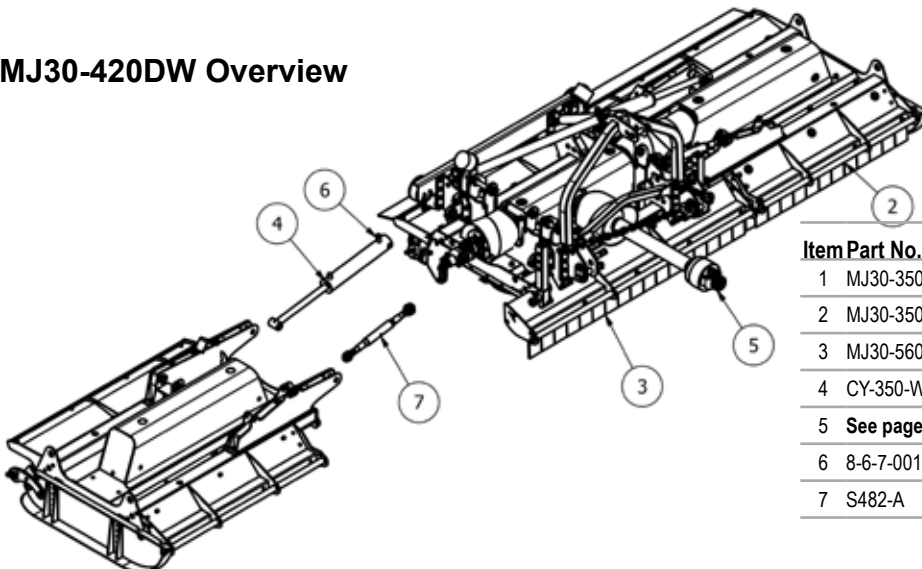

Item	Part No.	Description	Qty
1	MJ30-350-WGGA1	350 CYCLONE WING ASSY	1
2	MJ30-350-WGGA1LH	350 CYCLONE LEFT WING ASSY	1
3	MJ30-560-BDGA1	560 CYCLONE BODY ASSY	1
4	CY-350-WR	CYCLONE WING RAM	2
5	See page 39	PTO SHAFT	1
6	8-6-7-00161	3/8" BREATHER PLUG (68085600)	2
7	S482-A	CAT 1-2 TOP LINK	2

MJ30-630 Body - Linkage and Drivetrain assembly

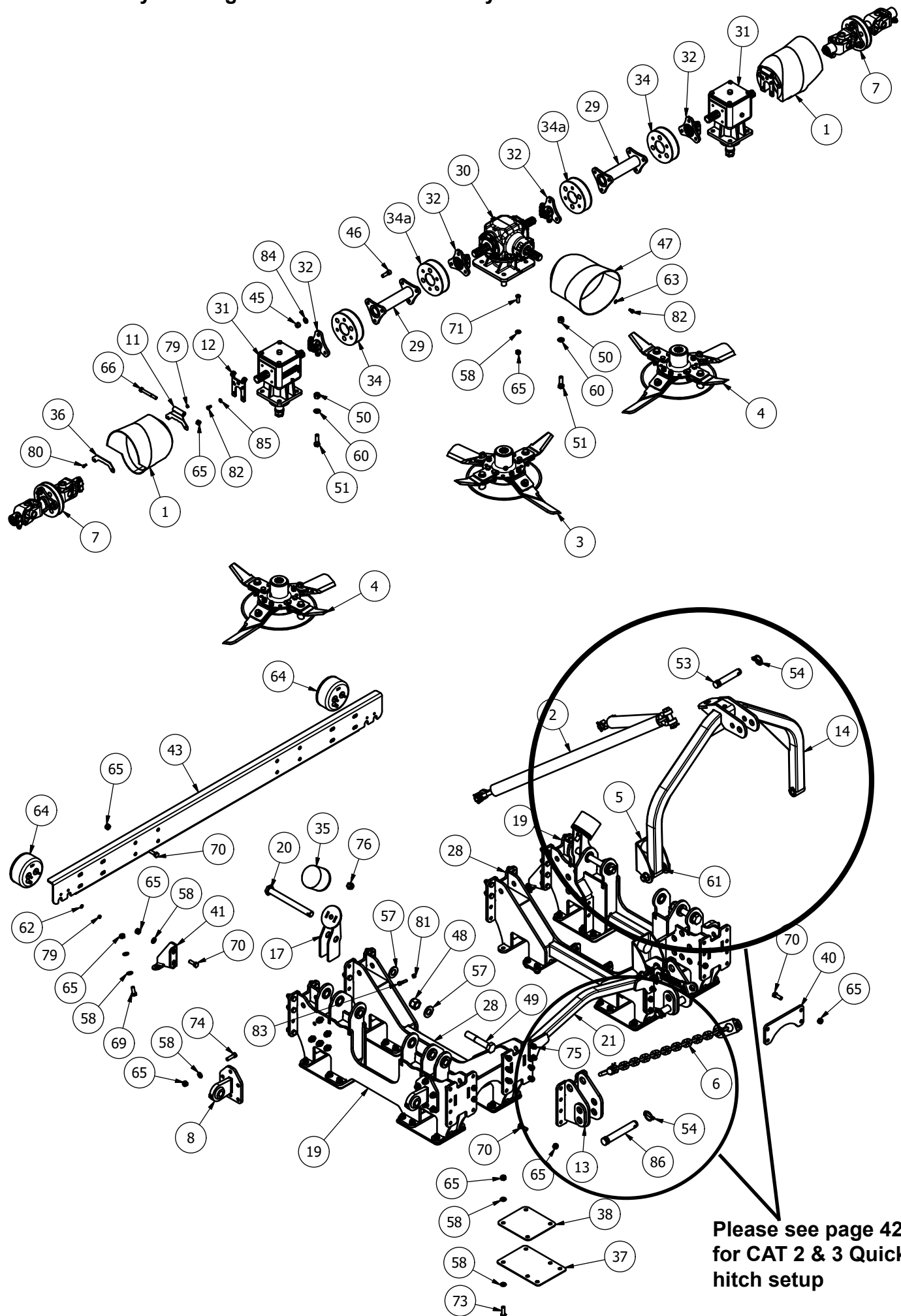

MJ30-630 Body - Parts list

Item Part No.	Description	Qty
1 MJ30-350-CVR30	MODIFIED OVAL GUARD	2
2* CYC-USLK40	HEAVY CHAIN SLING	2
3* 755-DCBLDHX2-L	755 BLADE (Anti_Cik)	1
4* 755-DCBLDHX2-R	755 BLADE (Cik)	2
5* AFB-GA1	A' FRAME BUFFER	2
6* CYC-CCHN01	CHECK CHAIN ASSY	2
7* CYC-WDR01	WING DRIVE ASSY	2
8 MJ30-350-PVE01	WING PIVOT EYE	4
9* MJ30-630-GRD20	630 BODY GUARD	1
10* MJ30-630-ROLB01	630 BODY ROLLER	1
11 11RM-C10	COVER PIVOT	2
12 11RM-C11	COVER PIVOT	2
13 2800CM-LK	LOWER LINK MOUNT	2
14 3000T-AF-01	3000T A-FRAME	1
15 3000T-RPV01	ROLLER ADJUSTER	1
16 3000T-RPV01-H	ROLLER ADJUSTER	1
17 MJ30-350-BF01	BUFFER STAND	2
18 MJ30-350-CVR20	GUARD BASE MOUNT	2
19 MJ30-350-LK01	LINKAGE/WING MOUNT	2
20 MJ30-350-LK30	PIVOT PIN	2
21 MJ30-350-LK40	LINKAGE TIE	1
22 MJ30-350-SD01	PARK STAND	2
23 MJ30-350-SKR01	CYCLONE REAR SKID	1
24 MJ30-350-SKR01H	REAR SKID	1
25 MJ30-630-BD01	630 CYCLONE BODY	1
26 MJ30-630-GRB01	TROUGH REINF' PANEL	1
27 MJ30-630-GRD01	630 BODY REAR GUARD	1
28 MJ30-630-LK01	LINKAGE MOUNT	2
29 0940B026001	254mm DRIVE	2
30 266.209	TF26A '4 WAY' RATIO 1:1.47	1
31 MJ40T11	6 SPLINE 'T' BOX RATIO 1:1 347805	2
32 DRV-6S-52DC	6 SPLINE 50mm DRIVE	4
33 MJ30-420-GRD35	REAR RUBBER FLAP	1
34 MJRC-113	113 PCD RUBBER COUPLING	2
34a MJRC-113-920	113 PCD HD RUBBER COUPLING	2
35 MOT75	DIA 100x75 BUFFER	2
36 11RM-C14	COVER MOUNT	2
37 2500CM-LK03	LINKAGE TIE	8
38 2500CM-LK09	UNDERSIDE SHIM	8
39 MJ30-420-GRD36	REAR RUBBER CLAMP	1
40 MJ30-630-LK41	LINKAGE TIE BASE	2
41 MJ30-350-GRD05	REAR GUARD SUPPORT	2
42 MJ30-630-CVR02	630 BODY COVER	1
43 MJ30-630-LK20	LINKAGE BRACE	1
44 3000T-SKD06	ROLLER PIVOT STUB	2
45 1/2HEX10.9	1/2F HEX 10.9	24
46 12x112FSKS	1/2"x1 1/2" FINE SOCKET HEAD 12.9	24
47 190.000.535	PTO GUARD OVAL WITH SLOT	1
48 1F	1" FINE NYLOC NUT	2
49 1x512FBZP	1"x5 1/2" FINE BOLT	2
50 5/8F	5/8" FINE NYLOC NUT	12
51 58x2FBZP	5/8"x2" FINE BOLT	12
52 73	CAT 1 PIN DIA 19x76mm	2
53 81	CAT 2 PIN DIA 25.4x110mm	1
54 AN099/10	LINCH PIN DIA 9.5	5
55 CP176-181MG1	45mm INSERT	2
56 CW39174	DISC SPRING 39x17x4 (YELLOW)	2
57 FW1	DIA 1" FLAT WASHER	4
58 FWM12	M12 FLAT WASHER	167
59 FWM12XL	M12 FLAT WASHER (EX-LARGE)	12
60 FWM16	M16 FLAT WASHER	16
61 FWM20	M20 FLAT WASHER	4
62 FWM6	M6 FLAT WASHER	4
63 FWM8	M8 FLAT WASHER	4
64 LALK017	LED LIGHT KIT	1
65 M12	M12 NYLOC NUT	155
66 M12x100BZP	M12x100 BOLT	2
67 M12x20SZP	M12x20 SET BOLT	8
68 M12x30SKBH	M12x30 SOCKET BUTTON HEAD 10.9	14
69 M12x30SZP	M12x30 SET BOLT	12
70 M12x35BZP	M12x35 BOLT	40
71 M12x35SKBH	M12x35 SOCKET BUTTON HEAD 10.9	2
72 M12x40BZP	M12x40 BOLT	5
73 M12x40SKBH	M12x40 SOCKET BUTTON HEAD 10.9	48
74 M12x40SKS	M12x40 SOCKET HEAD SCREW	24
75 M12x50BZP	M12x50 BOLT	8
76 M16	M16 NYLOC NUT	4
77 M16x30SZP	M16x30 SET BOLT	2
78 M16x50BZP	M16x50 BOLT	2
79 M6	M6 NYLOC NUT	8
80 M6x16SZP	M6x16 SET BOLT	4
81 M8	M8 NYLOC NUT	2
82 M8x16SZP	M8x16 SET BOLT	12
83 M8x40BZP	M8x40 BOLT	2
84 NL12SP	M12 SP NORDLOCK	32
85 NL8SP	M8 SP NORDLOCK	8
86 S112	CAT 2 PIN DIA 28.5x159mm	2
87 SP220-SIN	WELD CLAMP 20 ODx3/8" ID	3

*** - further breakdown provided**

MJ30-560/420DW Body - General Assembly

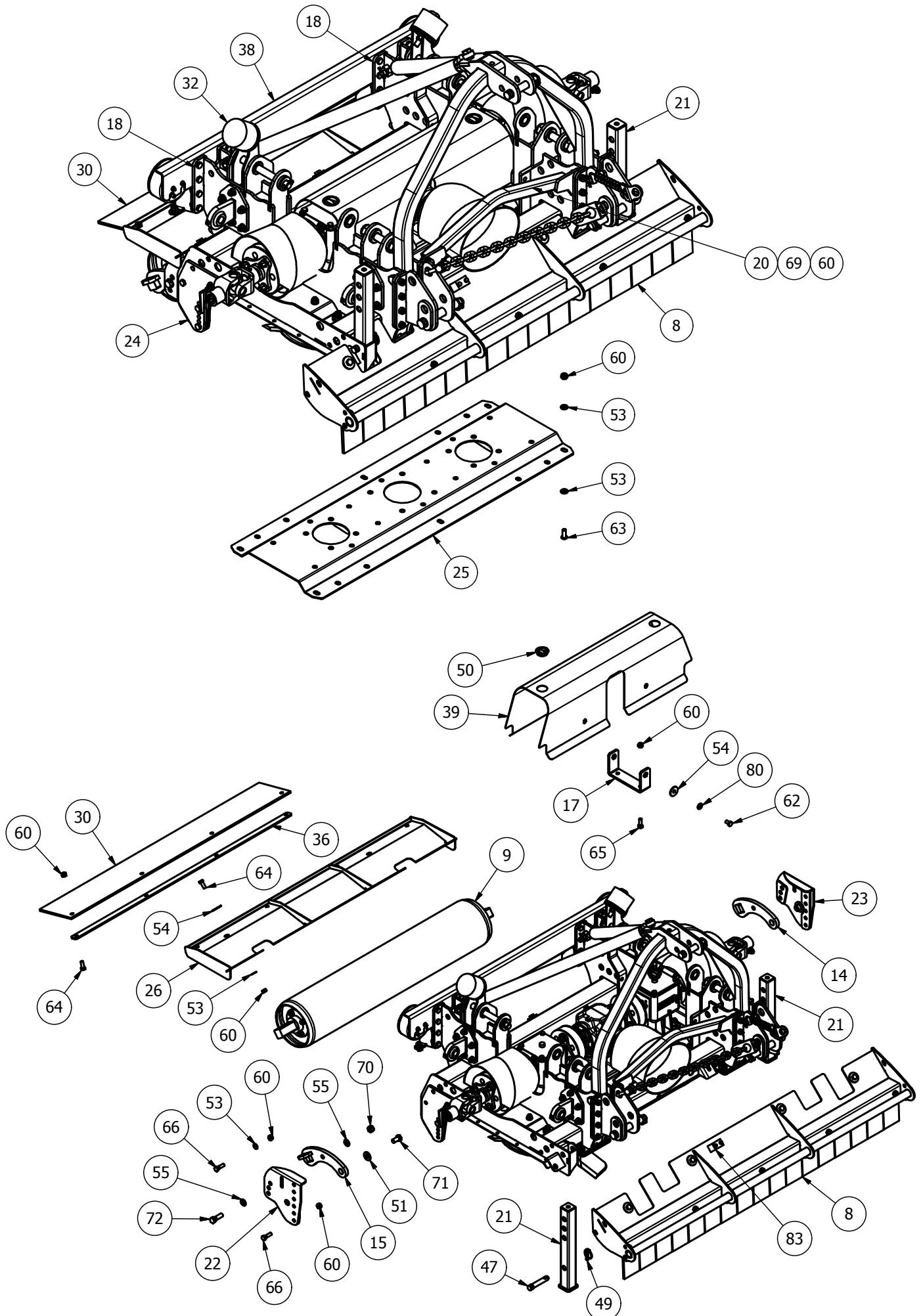

MJ30-560/420DW Body - Linkage and Drivetrain assembly

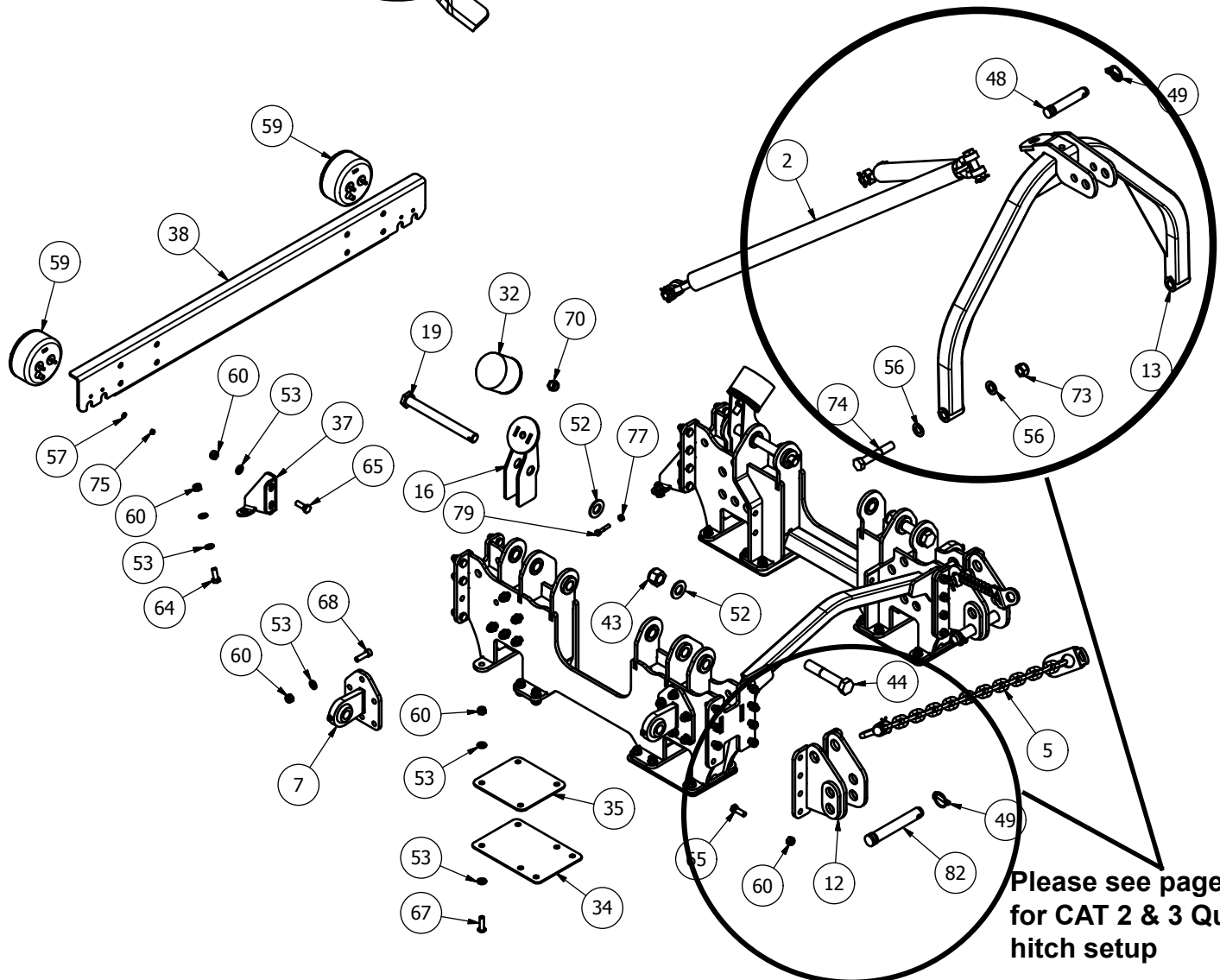
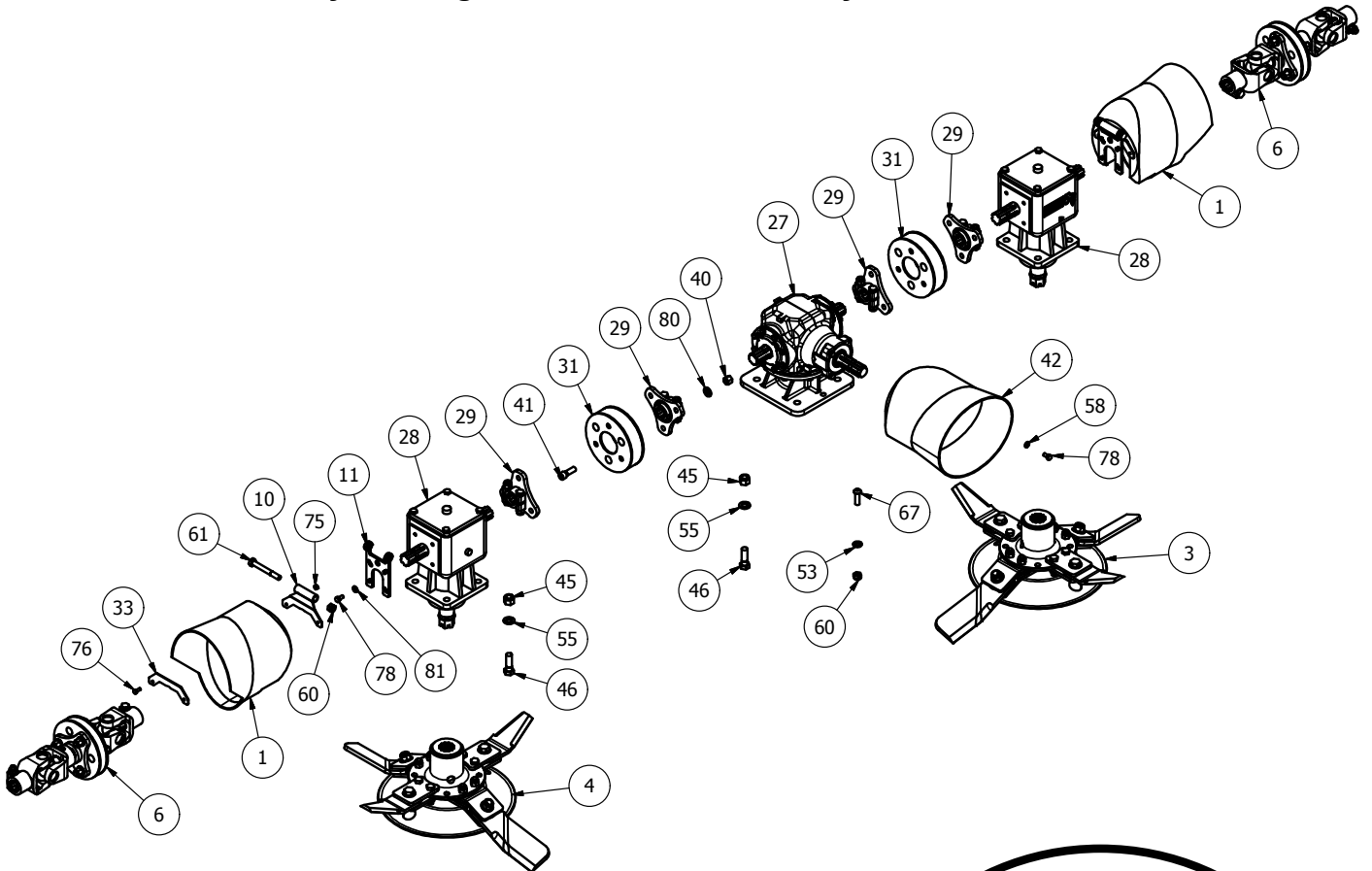

Please see page 42 for CAT 2 & 3 Quick hitch setup

MJ30-560/420DW Body - Parts list

Item Part No.	Description	Qty
1 MJ30-350-CVR30	MODIFIED OVAL GUARD	2
2* CYC-USLK40	HEAVY CHAIN SLING	2
3* 755-DCBLDHX2-L	755 BLADE (Anti Cik)	1
4* 755-DCBLDHX2-R	755 BLADE (Cik)	1
5* CYC-CCHN01	CHECK CHAIN ASSY	2
6* CYC-WDR01	WING DRIVE ASSY	2
7 MJ30-350-PVE01	WING PIVOT EYE	4
8* MJ30-560-GRD20	560 BODY GUARD	1
9* MJ30-560-ROLB01	560 BODY ROLLER	1
10 11RM-C10	COVER PIVOT	2
11 11RM-C11	COVER PIVOT	2
12 2800CM-LK	LOWER LINK MOUNT	2
13 3000T-AF-01	3000T A-FRAME	1
14 3000T-RPV01	ROLLER ADJUSTER	1
15 3000T-RPV01-H	ROLLER ADJUSTER	1
16 MJ30-350-BF01	BUFFER STAND	2
17 MJ30-350-CVR20	GUARD BASE MOUNT	2
18 MJ30-350-LK01	LINKAGE/WING MOUNT	2
19 MJ30-350-LK30	PIVOT PIN	2
20 MJ30-350-LK40	LINKAGE TIE	1
21 MJ30-350-SD01	PARK STAND	2
22 MJ30-350-SKR01	CYCLONE REAR SKID	1
23 MJ30-350-SKR01H	REAR SKID	1
24 MJ30-560-BD01	560 CYCLONE BODY	1
25 MJ30-560-GRB01	TROUGH REINF' PANEL	1
26 MJ30-560-GRD01	BODY REAR GUARD	1
27 266.207-S	TF26A 'T' 1:1.47 3 WAY SHORT	1
28 MJ40T11	6 SPLINE 'T' BOX RATIO 1:1	2
29 CM25-DRV	6 SPLINE STAR DRIVE	4
30 MJ30-350-GRD35	REAR RUBBER FLAP	1
31 MJRC-113 (MJ30-420DW only)	113 PCD RUBBER COUPLING	2
31 MJRC-113-920 (MJ30-560 only)	113 PCD HD RUBBER COUPLING	2
32 MOT75	DIA 100x75 BUFFER	2
33 11RM-C14	COVER MOUNT	2
34 2500CM-LK03	LINKAGE TIE	4
35 2500CM-LK09	UNDERSIDE SHIM	4
36 MJ30-350-GRD36	REAR RUBBER CLAMP	1
37 MJ30-350-GRD05	REAR GUARD SUPPORT	2
38 MJ30-350-LK20	LINKAGE BRACE	1
39 MJ30-560-CVR02	560 BODY COVER	1
40 1/2HEX10.9	1/2F HEX 10.9	12
41 12x112FSKS	1/2"x1 1/2" FINE SKT HEAD 12.9	12
42 190.000.535	PTO GUARD OVAL WITH SLOT	1
43 1F	1" FINE NYLOC NUT	2
44 1x512FBZP	1"x5 1/2" FINE BOLT	2
45 5/8F	5/8" FINE NYLOC NUT	12
46 58x2FBZP	5/8"x2" FINE BOLT	12
47 73	CAT 1 PIN DIA 19x76mm	2
48 81	CAT 2 PIN DIA 25.4x110mm	1
49 AN099/10	LINCH PIN DIA 9.5	5
50 CP176-181MG1	45mm INSERT	2
51 CW39174	DISC SPRING 39x17x4 (YELLOW)	2
52 FW1	DIA 1" FLAT WASHER	4
53 FWM12	M12 FLAT WASHER	114
54 FWM12XL	M12 FLAT WASHER (EX-LARGE)	7
55 FWM16	M16 FLAT WASHER	16
56 FWM20	M20 FLAT WASHER	6
57 FWM6	M6 FLAT WASHER	4
58 FWM8	M8 FLAT WASHER	4
59 LALK027	LED LIGHT KIT	1
60 M12	M12 NYLOC NUT	112
61 M12x100BZP	M12x100 BOLT	2
62 M12x20SZP	M12x20 SET BOLT	4
63 M12x30SKBH	M12x30 SKT BUTTON HEAD 10.9	14
64 M12x30SZP	M12x30 SET BOLT	9
65 M12x35BZP	M12x35 BOLT	28
66 M12x40BZP	M12x40 BOLT	5
67 M12x40SKBH	M12x40 SKT BUTTON HEAD 10.9	26
68 M12x40SKS	M12x40 SOCKET HEAD SCREW	24
69 M12x50BZP	M12x50 BOLT	4
70 M16	M16 NYLOC NUT	4
71 M16x30SZP	M16x30 SET BOLT	2
72 M16x50BZP	M16x50 BOLT	2
73 M20	M20 NYLOC NUT	2
74 M20x120BZP	M20x120 BOLT	2
75 M6	M6 NYLOC NUT	8
76 M6x16SZP	M6x16 SET BOLT	4
77 M8	M8 NYLOC NUT	2
78 M8x16SZP	M8x16 SET BOLT	12
79 M8x40BZP	M8x40 BOLT	2
80 NL12SP	M12 SP NORDLOCK	16
81 NL8SP	M8 SP NORDLOCK	8
82 S112	CAT 2 PIN DIA 28.5x159mm	2
83 SP220-SIN	WELD CLAMP 20 ODx3/8" ID	3

*** - further breakdown provided**

MJ30-560/630 Wing - General assembly and Drivetrain

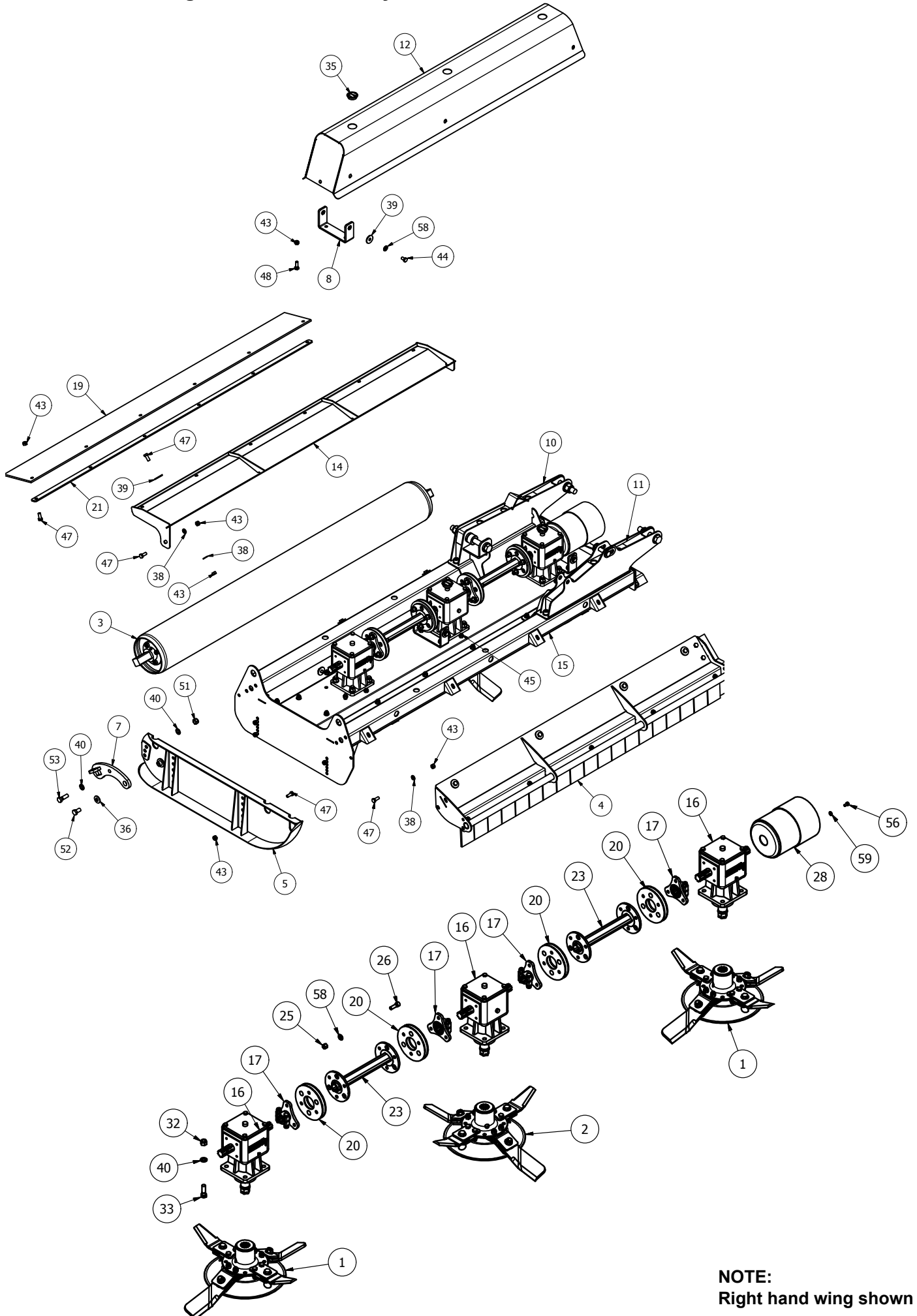

NOTE:
Right hand wing shown

MJ30-560/630 Wing - Parts list

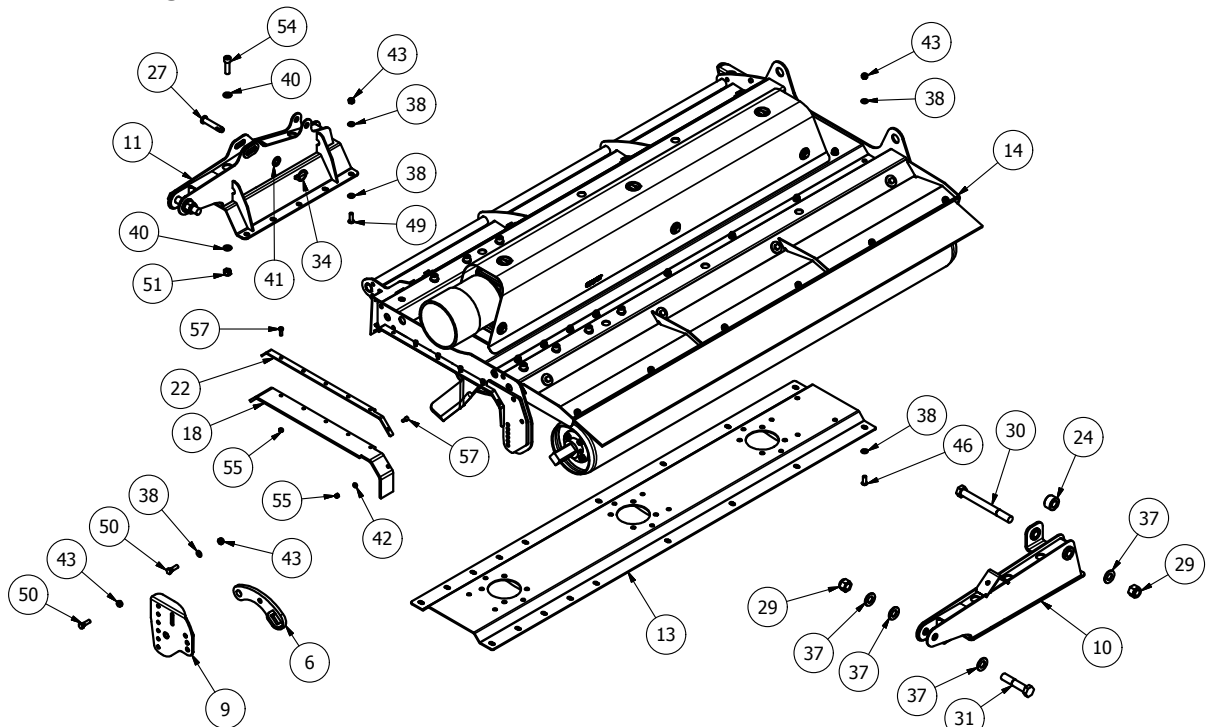

MJ30-420/560 Wing - Parts list

Item Part No.	Description	Qty	27 15012	CAT 1 PIN DIA 19x76mm	1
1* 755-DCBLDX2-L	755 BLADE (Anti_Clk)	2	28 190760	GUARD (COVER 760/BASE 661)	1
2* 755-DCBLDX2-R	755 BLADE (Clk)	1	29 1F	1" FINE NYLOC NUT	3
3* MJ30-350-ROLB01	350 BODY ROLLER	1	30 1x10FBZP	1"x10" FINE BOLT	1
4* MJ30-420-GRD50	420 WING GUARD RH	1	31 1x5FBZP	1"x5" FINE BOLT	2
4* MJ30-420-GRD50H	420 WING GUARD LH	1	32 5/8F	5/8" FINE NYLOC NUT	12
5 2500CM-SKDR	2500CM R/HAND SKID	1	33 5/8x2FBZP	5/8"x2" FINE BOLT	12
5 2500CM-SKDL	2500CM L/HAND SKID	1	34 AN099/10	LINCH PIN DIA 9.5	1
6 3000T-RPV01	ROLLER ADJUSTER	1	35 CP176-181MG1	45mm INSERT	3
7 3000T-RPV01-H	ROLLER ADJUSTER	1	36 CW39174	DISC SPRING 39x17x4 (YELLOW)	2
8 MJ30-350-CVR20	GUARD BASE MOUNT	3	37 FW1	DIA 1" FLAT WASHER	7
9 MJ30-350-SKR01	REAR SKID	1	38 FWM12	M12 FLAT WASHER	47
9 MJ30-350-SKR01H	REAR SKID	1	39 FWM12XL	M12 FLAT WASHER (EX-LARGE)	10
10 MJ30-350-WA01	WING ARM	1	40 FWM16	M16 FLAT WASHER	32
10 MJ30-350-WA01H	WING ARM	1	41 FWM20	M20 FLAT WASHER	1
11 MJ30-350-WA20	WING ARM (LINKAGE)	1	42 FWM8	M8 FLAT WASHER	2
11 MJ30-350-WA20H	WING ARM (LINKAGE)	1	43 M12	M12 NYLOC NUT	51
12 MJ30-420-CVR10	420 WING COVER	1	44 M12x20SZP	M12x20 SET BOLT	6
13 MJ30-420-GRB20	TROUGH REINF' PANEL	1	45 M12x25SZP	M12x25 SET BOLT	6
14 MJ30-420-GRD30	WING REAR GUARD RH	1	46 M12x30SKBH	M12x30 SKT BUTTON HEAD 10.9	10
14 MJ30-420-GRD30H	WING REAR GUARD LH	1	47 M12x30SZP	M12x30 SET BOLT	16
15 MJ30-420-WG01	420 WING RH	1	48 M12x35BZP	M12x35 BOLT	6
15 MJ30-420-WG01H	420 WING LH	1	49 M12x35SKBH	M12x35 SKT BUTTON HEAD 10.9	10
16 MJ40T11	6 SPLINE 'T' BOX RATIO 1:1	3	50 M12x40BZP	M12x40 BOLT	3
17 DRV-6S-52DC	6 SPLINE 50mm DRIVE	4	51 M16	M16 NYLOC NUT	10
18 MJ30-350-GRD41H	WING RUBBER	1	52 M16x30SZP	M16x30 SET BOLT	2
19 MJ30-420-GRD35	REAR RUBBER FLAP	1	53 M16x50BZP	M16x50 BOLT	2
20 MJRC-23	113 PCD COUPLING 4mm PLT	4	54 M16x55SKZP129	M16x55 SOCKET HEAD 12.9	8
21 MJ30-420-GRD36	REAR RUBBER CLAMP	1	55 M8	M8 NYLOC NUT	7
22 MJ30-350-GRD40	WING CLAMP RH	1	56 M8x16SZP	M8x16 SET BOLT	4
22 MJ30-350-GRD40H	WING CLAMP LH	1	57 M8x25BZP	M8x25 BOLT	7
23 DRV-RC-SWT410	MJ70-410 DRIVE	2	58 NL12SP	M12 SP NORDLOCK	30
24 MJ30-350-WA11	RAM SPACER	1	59 NL8SP	M8 SP NORDLOCK	4
25 1/2HEX10.9	1/2F HEX 10.9	24			
26 12x112FSKS	1/2"x1 1/2" FINE SKT HEAD 12.9	24			

* - further breakdown provided

MJ30-420DW Wing Assembly

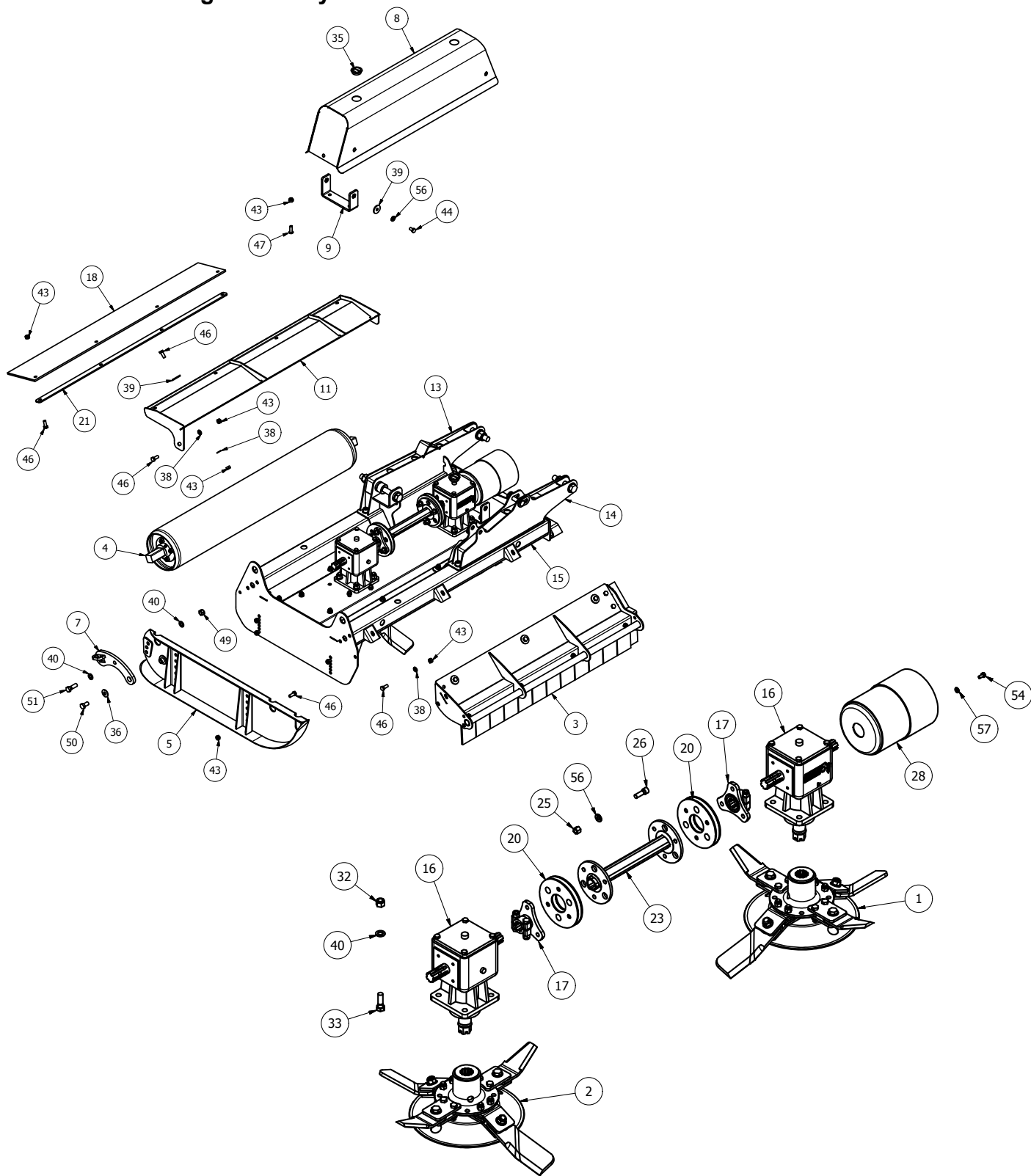

MJ30-420DW Wing Assembly

Item	Part No.	Description	Qty	Part No.	Description	Qty
	8	MJ30-350-CVR10	350 WING COVER	1	1	
	9	MJ30-350-CVR20	GUARD BASE MOUNT	2	2	
	10	MJ30-350-GRB20	TROUGH REINF' PANEL	1	1	
	11	MJ30-350-GRD30	WING REAR GUARD RH	1	1	
	11	MJ30-350-GRD30H	WING REAR GUARD LH	1	1	
	12	MJ30-350-SKR01	REAR SKID	1	1	
	12	MJ30-350-SKR01H	REAR SKID	1	1	
	13	MJ30-350-WA01	WING ARM	1	1	
	13	MJ30-350-WA01H	WING ARM	1	1	
	14	MJ30-350-WA20	WING ARM (LINKAGE)	1	1	
1*	755-DCBLDHX2-L	755 BLADE (Anti_Clk)	1			
2*	755-DCBLDHX2-R	755 BLADE (Clk)	1			
3*	MJ30-350-GRD50	350 WING GUARD	1			
3*	MJ30-350-GRD50H	350 WING GUARD	1			
4*	MJ30-350-ROLW01	350 WING ROLLER	1			
5	2500CM-SKDR	2500CM R/HAND SKID RH	1			
5	2500CM-SKDL	2500CM R/HAND SKID LH	1			
6	3000T-RPV01	ROLLER ADJUSTER	1			
7	3000T-RPV01-H	ROLLER ADJUSTER	1			

MJ30-420DW Wing Assembly

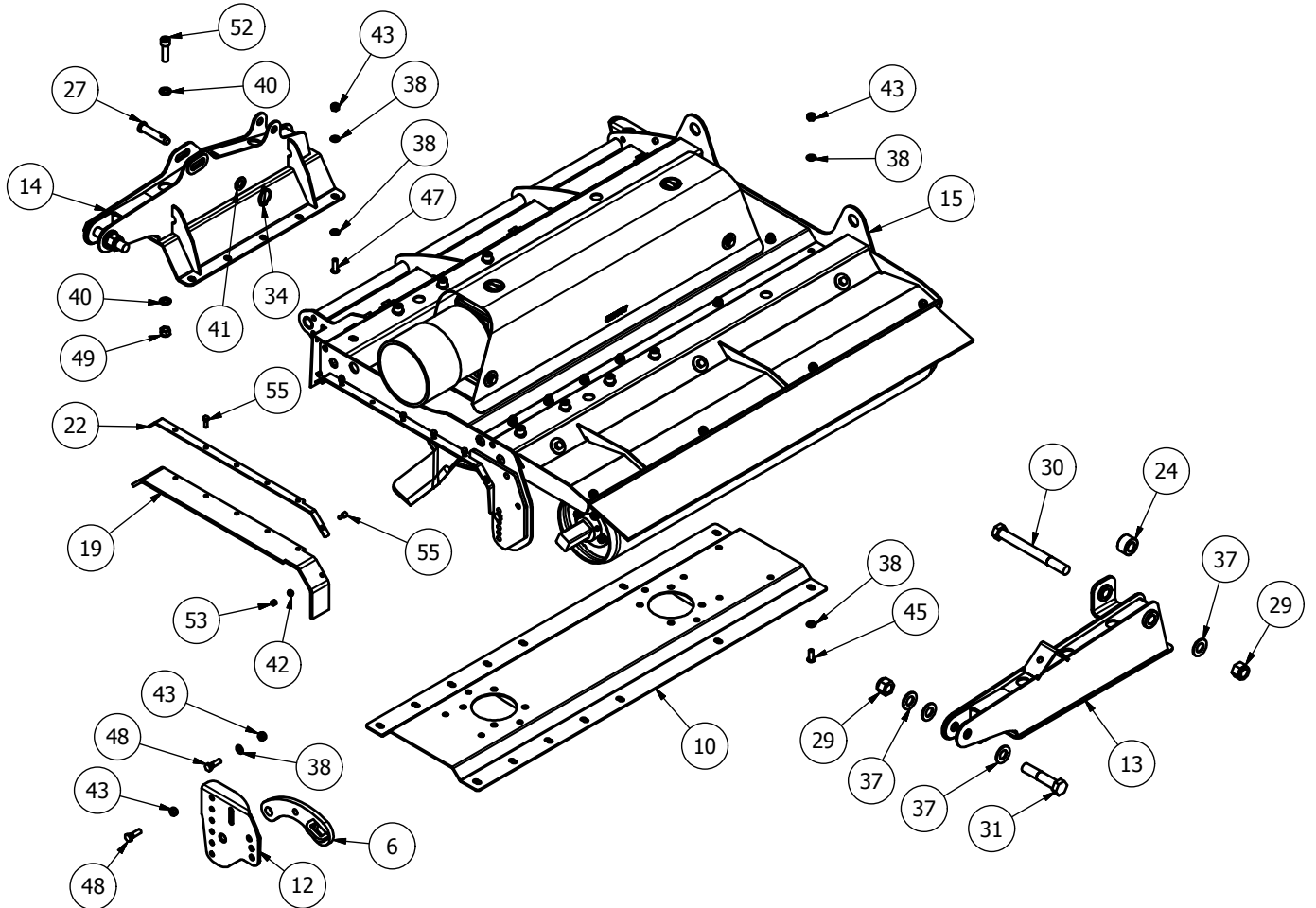

MJ30-420DW Wing Assembly - Parts List

14	MJ30-350-WA20H	WING ARM (LINKAGE)	1	38	FWM12	M12 FLAT WASHER	38
15	MJ30-350-WG01	350 WING	1	39	FWM12XL	M12 FLAT WASHER (EX-LARGE)	7
16	MJ40T11	6 SPLINE 'T' BOX 1:1 (347.805) 1000 RPM (MJ30-420DW)	2	40	FWM16	M16 FLAT WASHER	28
17	DRV-6S-52DC	6 SPLINE 50mm DRIVE	2	41	FWM20	M20 FLAT WASHER	1
18	MJ30-350-GRD35	REAR RUBBER FLAP	1	42	FWM8	M8 FLAT WASHER	2
19	MJ30-350-GRD41H	WING RUBBER	1	43	M12	M12 NYLOC NUT	40
20	MJRC-23	113 PCD COUPLING 4mm PLT	2	44	M12x20SZP	M12x20 SET BOLT	4
21	MJ30-350-GRD36	REAR RUBBER CLAMP	1	45	M12x30SKBH	M12x30 SOCKET BUTTON HEAD 10.9	10
22	MJ30-350-GRD40	WING CLAMP RH	1	46	M12x30SZP	M12x30 SET BOLT	13
22	MJ30-350-GRD40H	WING CLAMP LH	1	47	M12x35SKBH	M12x35 SOCKET BUTTON HEAD 10.9	14
23	DRV-RC-SWT410	MJ70-410 DRIVE	1	48	M12x40BZP	M12x40 BOLT	3
24	MJ30-350-WA11	RAM SPACER	1	49	M16	M16 NYLOC NUT	10
25	1/2HEX10.9	1/2F HEX 10.9	12	50	M16x30SZP	M16x30 SET BOLT	2
26	12x112FSKS	1/2"x1 1/2" FINE SOCKET HEAD 12.9	12	51	M16x50BZP	M16x50 BOLT	2
27	15012	CAT 1 PIN DIA 19x76mm	1	52	M16x55SKZP129	M16x55 SOCKET HEAD 12.9	8
28	190760	GUARD (COVER 760/BASE 661)	1	53	M8	M8 NYLOC NUT	7
29	1F	1" FINE NYLOC NUT	3	54	M8x16SZP	M8x16 SET BOLT	4
30	1x10FBZP	1"x10" FINE BOLT	1	55	M8x25BZP	M8x25 BOLT	7
31	1x5FBZP	1"x5" FINE BOLT	2	56	NL12SP	M12 SP NORDLOCK	16
32	5/8F	5/8" FINE NYLOC NUT	8	57	NL8SP	M8 SP NORDLOCK	4
33	58x2FBZP	5/8"x2" FINE BOLT	8	* - further breakdown provided			
34	AN099/10	LINCH PIN DIA 9.5	1				
35	CP176-181MG1	45mm INSERT	2				
36	CW39174	DISC SPRING 39x17x4 (YELLOW)	2				
37	FW1	DIA 1" FLAT WASHER	7				

Front Guards assembly (MJ30-560/630/420DW)

MJ30-560/630 Wing

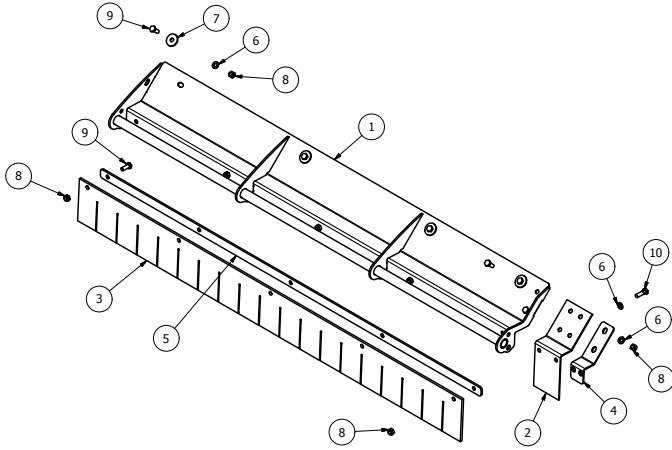

Item	Part No.	Description	Qty
1	MJ30-420-GRD51	FLAP GUARD MOUNT RH	1
1	MJ30-420-GRD51H	FLAP GUARD MOUNT LH	1
2	MJ30-350-GRD56	WING RUBBER FLAP	1
3	MJ30-420-GRD60	GUARD RUBBER (WING)	1
4	MJ30-350-GRD57	WING GUARD PLATE	1
5	MJ30-420-GRD61	WING RUBBER CLAMP	1
6	FWM12	M12 FLAT WASHER	7
7	FWM12XL	M12 FLAT WASHER (EX-LARGE)	4
8	M12	M12 NYLOC NUT	11
9	M12x30SZP	M12x30 SET BOLT	10
10	M12x40BZP	M12x40 BOLT	1

MJ30-420DW Wing

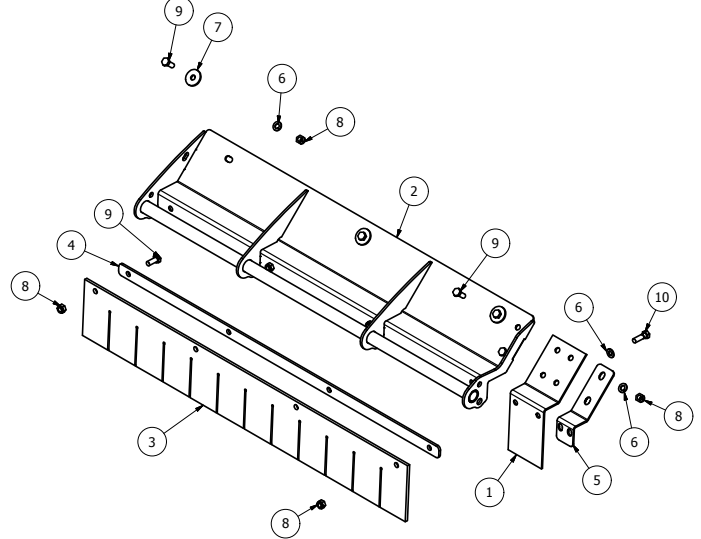

Item	Part No.	Description	Qty
1	MJ30-350-GRD56	WING RUBBER FLAP	1
2	MJ30-350-GRD51	FLAP GUARD MOUNT RH	1
2	MJ30-350-GRD51H	FLAP GUARD MOUNT LH	1
3	MJ30-350-GRD16	GUARD RUBBER (WING)	1
4	MJ30-350-GRD17	WING RUBBER CLAMP	1
5	MJ30-350-GRD57	WING GUARD PLATE	1
6	FWM12	M12 FLAT WASHER	6
7	FWM12XL	M12 FLAT WASHER (X-LRG)	3
8	M12	M12 NYLOC NUT	9
9	M12x30SZP	M12x30 SET BOLT	8
10	M12x40BZP	M12x40 BOLT	1

MJ30-630 Body (MJ30-630-GRD20)

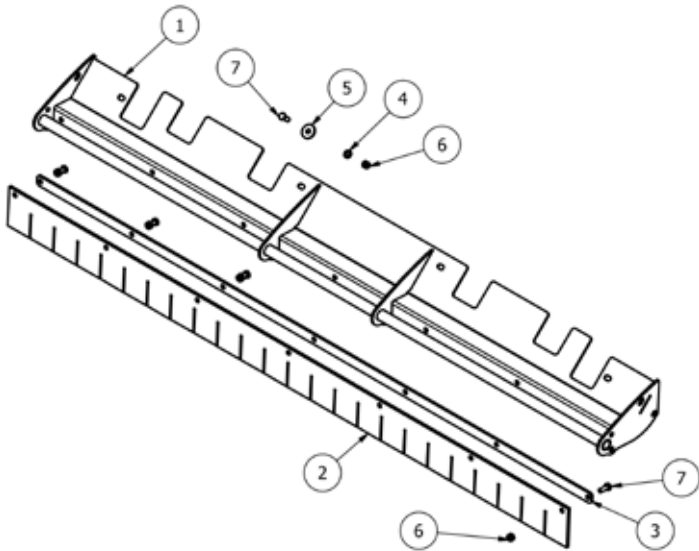

Item	Part No.	Description	Qty
1	MJ30-630-GRD21	FLAP GUARD MOUNT	1
2	MJ30-630-GRD60	GUARD RUBBER (BODY)	1
3	MJ30-630-GRD61	BODY RUBBER CLAMP	1
4	FWM12	M12 FLAT WASHER	4
5	FWM12XL	M12 FLAT WASHER (EX-LARGE)	4
6	M12	M12 NYLOC NUT	11
7	M12x30SZP	M12x30 SET BOLT	11

MJ30-560/420DW Body

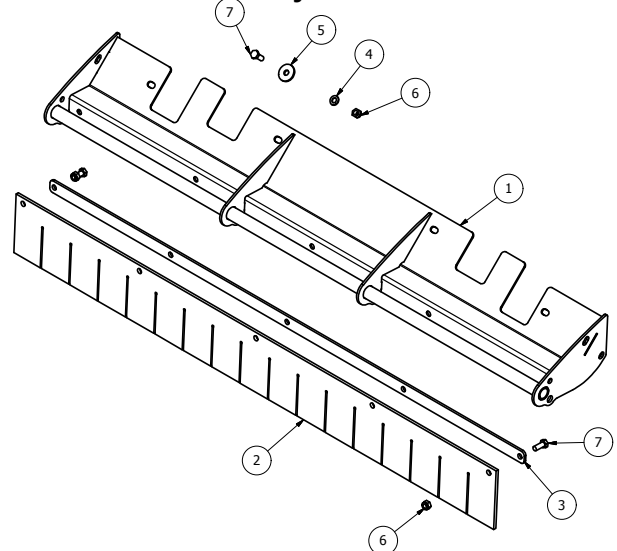

Item	Part No.	Description	Qty
1	MJ30-560-GRD21	FLAP GUARD MOUNT	1
2	MJ30-560-GRD60	GUARD RUBBER (WING)	1
3	MJ30-560-GRD61	BODY RUBBER CLAMP	1
4	FWM12	M12 FLAT WASHER	4
5	FWM12XL	M12 FLAT WASHER EX-LARGE	4
6	M12	M12 NYLOC NUT	9
7	M12x30SZP	M12x30 SET BOLT	9

MJ31-280 General assembly

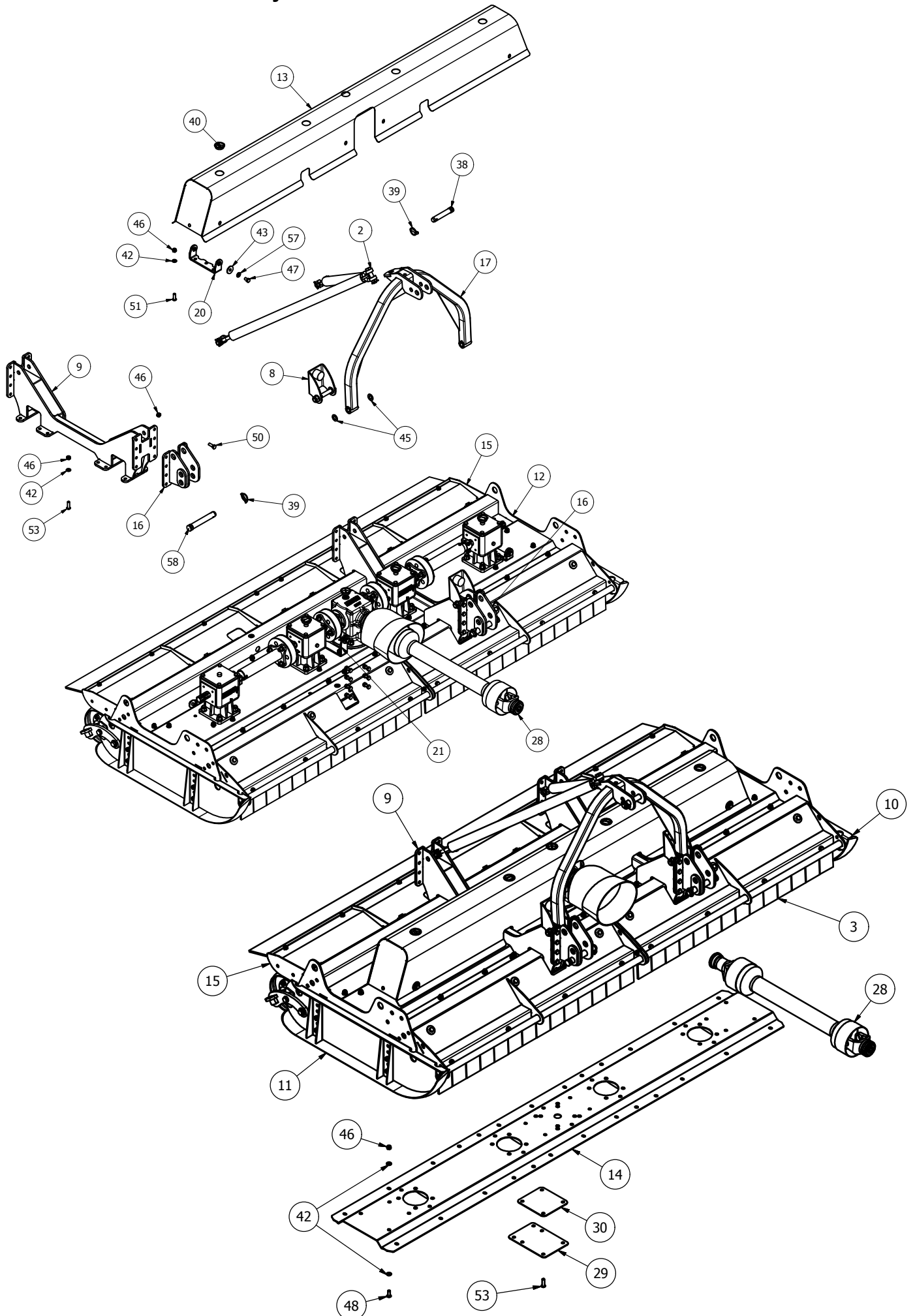

MJ31-280 General assembly

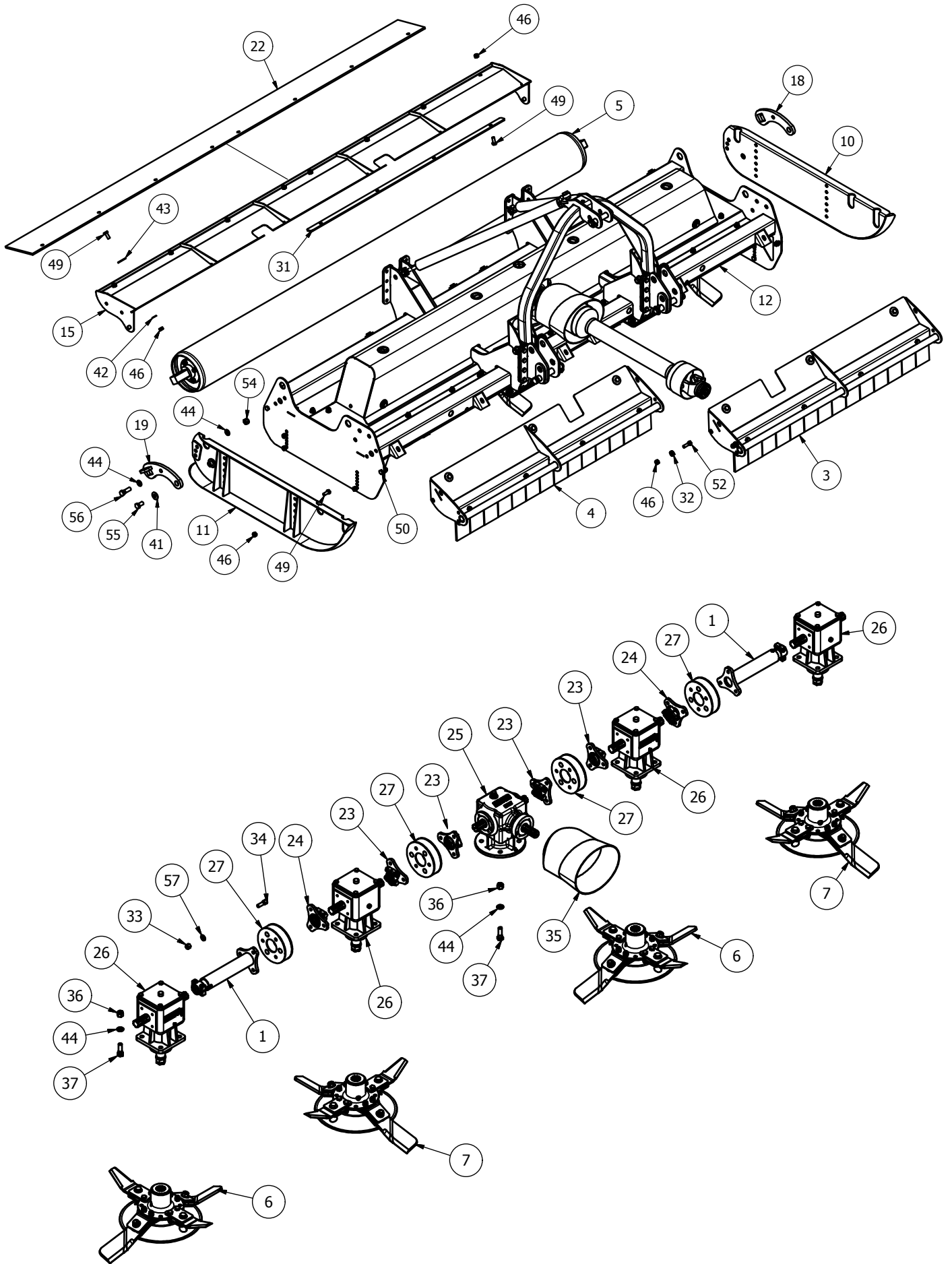

MJ31-280 Parts

Item Part No.	Description	Qty					
1	15GM-WDT	DRIVE TUBE (355mm)	2	32	8SM9-3	BLADE BACK SPACER	2
2*	2500CM-STRP01	2500 CHAIN SLING	1	33	1/2HEX10.9	1/2F HEX 10.9	24
3*	280-CYC-GRD-FLPL2	280 CYC FLAP GUARD	1	34	12x112FSKS	1/2"x1 1/2" FINE SOCKET HEAD 12.9	24
4*	280-CYC-GRD-FLPR	280 CYC FLAP GUARD	1	35	190.000.545	PTO GUARD (EXTENDED OVAL)	1
5*	2800CM-ROL01	280 CYCLONE ROLLER	1	36	5/8F	5/8" FINE NYLOC NUT	20
6*	755-DCBLDHTX5-L	755 BLADE (Anti_Clk)	2	37	58x2FBZP	5/8"x2" FINE BOLT	20
7*	755-DCBLDHTX5-R	755 BLADE (Clk)	2	38	81	CAT 2 PIN DIA 25.4x110mm	1
8*	AFB-GA1	A' FRAME BUFFER	2	39	AN099/10	LINCH PIN DIA 9.5	3
9	2500CM-LK20	LINKAGE MOUNT	2	40	CP176-181MG1	45mm INSERT	5
10	2500CM-SKDL	2500T L/HAND SKID	1	41	CW39174	DISC SPRING 39x17x4 (YELLOW)	2
11	2500CM-SKDR	2500CM R/HAND SKID	1	42	FWM12	M12 FLAT WASHER	112
12	2800CM-B4R10	280 CYCLONE BODY	1	43	FWM12XL	M12 FLAT WASHER (EX-LARGE)	14
13	2800CM-CVR2	GEARBOX COVER	1	44	FWM16	M16 FLAT WASHER	24
14	2800CM-GR	TROUGH REINFORCER PANEL	1	45	FWM20	M20 FLAT WASHER	4
15	2800CM-GRD01	ROLLER GUARD	1	46	M12	M12 NYLOC NUT	108
16	2800CM-LK	LOWER LINK MOUNT	2	47	M12x20SZP	M12x20 SET BOLT	8
17	3000T-AF-01	3000T A-FRAME	1	48	M12x30SKBH	M12x30 SOCKET BUTTON HEAD 10.9	30
18	3000T-RPV01	ROLLER ADJUSTER	1	49	M12x30SZP	M12x30 SET BOLT	24
19	3000T-RPV01-H	ROLLER ADJUSTER	1	50	M12x35BZP	M12x35 BOLT	18
20	8400RM-CV14	GUARD BASE MOUNT	2	51	M12x35SKBH	M12x35 SOCKET BUTTON HEAD 10.9	10
21	8400RM-CV20	GUARD BASE MOUNT	2	52	M12x40BZP	M12x40 BOLT	2
22	2800CM-GRD20	REAR RUBBER FLAP	1	53	M12x40SKBH	M12x40 SOCKET BUTTON HEAD 10.9	24
23	CM25-DRV	6 SPLINE STAR DRIVE	4	54	M16	M16 NYLOC NUT	2
24	DRV-6S-52DC	6 SPLINE 50mm DRIVE	2	55	M16x30SZP	M16x30 SET BOLT	2
25	JJ.03499	6 SPLINE 'T' BOX 1:1.9	1	56	M16x50BZP	M16x50 BOLT	2
26	MJ40T (347801)	6 SPLINE 'T' BOX RATIO 1.47	4	57	NL12SP	M12 SP NORDLOCK	32
27	MJRC-113	113 PCD RUBBER COUPLING	4	58	S112	CAT 2 PIN DIA 28.5x159mm	2
28	See page 39	PTO SHAFT	1	* - further breakdown provided			
29	2500CM-LK03	LINKAGE TIE	4				
30	2500CM-LK09	UNDERSIDE SHIM	4				
31	2800CM-GRD-FLP03	GUARD RUBBER CLAMP	2				

MJ31-280 - Front Guard Assembly

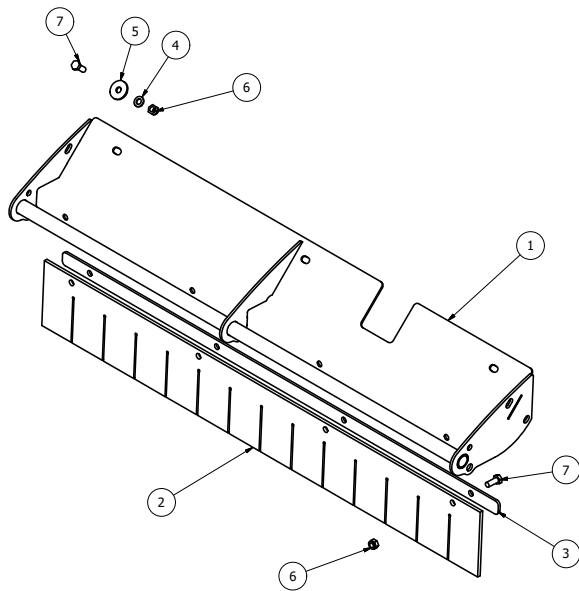

Item	Part No.	Description	Qty
1	2800CM-GRD-FLR	FLAP GUARD MOUNT (SHOWN)	1
1	2800CM-GRD-FLL2	FLAP GUARD MOUNT	1
2	280-CYC-GRD-FLP04	FRONT GUARD RUBBER	1
3	2800CM-GRD-FLP03	GUARD RUBBER CLAMP	1
4	FWM12	M12 FLAT WASHER	3
5	FWM12XL	M12 FLAT WASHER (EX-LARGE)	3
6	M12	M12 NYLOC NUT	7
7	M12x30SZP	M12x30 SET BOLT	7

Roller Assembly (All models)

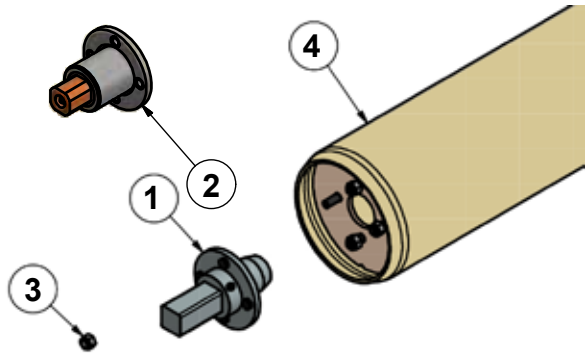

Item	Part No.	Description	Qty per Machine
1	3000T-ROL07	ROLLER AXLE STUB	2 per roller
2	CYC-AXH2-01	AXLE HOUSING	2 per roller
3	22204 57312B1	M12 FINE WHEEL NUT	8 per roller
4	MJ30-350-ROLB02	350 BODY ROLLER	2 per MJ30-560 (Wing) 2 per MJ30-630 (Wing)
4	MJ30-560-ROLB02	560 BODY ROLLER	1 per MJ30-560/420DW (Body)
4	MJ30-630-ROLB02	630 BODY ROLLER	1 per MJ30-630 (Body)
4	MJ30-350-ROLW02	350 WING ROLLER	2 per MJ30-420DW (Wing)
4	2800CM-ROL02	2800CM ROLLER	1 per MJ31-280

Roller axle stub assembly (3000T-ROL07)

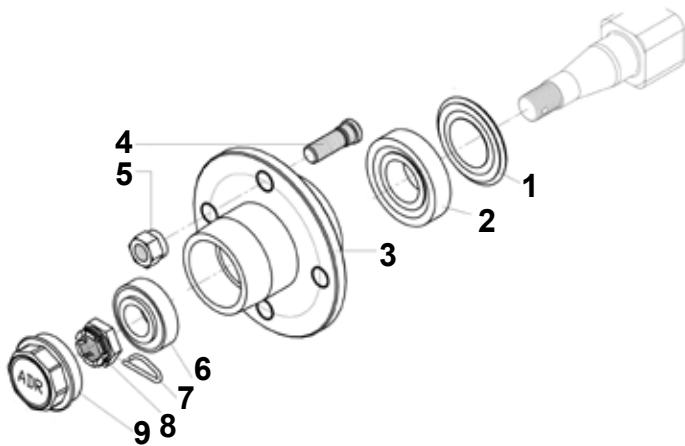

Item	Part No.	Description	Qty
1	30X62	SEAL	1
2	30206	BEARING	1
3	TWA-052	HUB	1
4	22205	STUD	4
5	22206	NUT	4
6	30204	BEARING	1
7	1500	SPLIT PIN	1
8	20033	CASTLE NUT	1
9	20040/1	DUST CAP	1

Axle housing (CYC-AXH2-01)

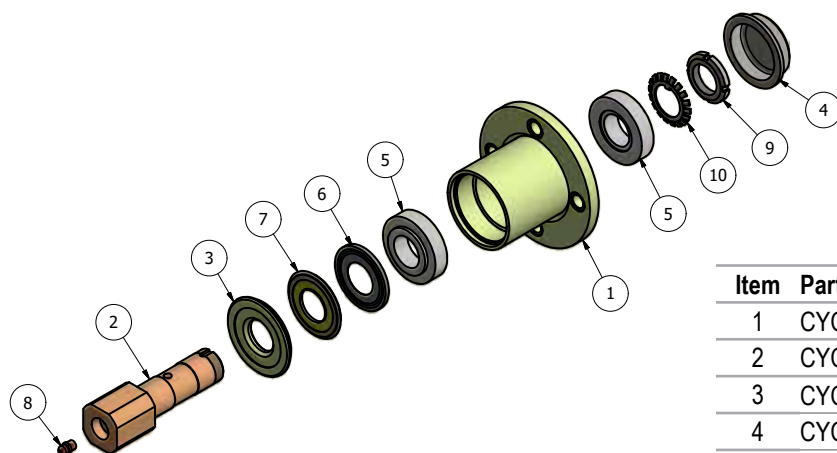

Item	Part No.	Description	Qty
1	CYC-AXH2-10	AXLE HOUSING	1
2	CYC-AXH2-21	AXLE SHAFT	1
3	CYC-AXH2-22	SEAL SPACER	1
4	CYC-AXH2-23	END CAP	1
5	30206	TAPER BRG 62x30x17.25	2
6	30206-AV	NILOS RING 62x30	1
7	5410621	DIA 30xDIA 62.3mm WIPE SEAL	1
8	851	GREASE NIPPLE M8x1.25 STR	1
9	KM6	M30x1.5P LOCK NUT	1
10	MB6	DIA 30mm LOCK TAB	1

PTO shafts

Item	Part No.	Description	Machines	Safety
1	604324	Rear mount Walterscheid 2500 (greased)	MJ31-280, MJ30-420DW	SB/OR M10x60 8.8 (2920Nm)
2	607400	Rear mount Walsterscheid (1 3/4" 20 spline)	MJ30-420DW/560/630	SB/OR M10x60 8.8 (2920Nm)
	607399	Rear mount Walsterscheid (1 3/8" 21 spline)	MJ30-420DW/560/630	SB/OR M10x60 8.8 (2920Nm)

MJ30-420DW/560/630 Wing PTO assembly (CYC-WDR01)

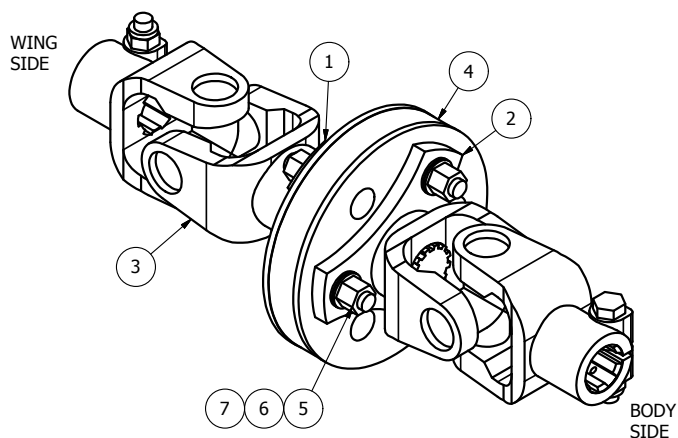

Item Part No.	Description	Qty
1	CYC-WDR10 SPLINE BUSH DRIVE	1
2	CYC-WDR20 SPLINE YOKE DRIVE	1
3	CYC-WDR30 Z12 SHAFT YOKE	1
4	MJRC-23-5 113 PCD COUPLING 5mm PLT	1
5	1/2HEX10.9 1/2F HEX 10.9	6
6	12x112FSKS 1/2"x1 1/2" FINE SOCKET HEAD 12.9	6
7	NL12SP M12 SP NORDLOCK	6

**YOKE ENDS MUST BE
ALIGNED AS SHOWN.**

PTO shaft (607399) 1-3/8”(21)

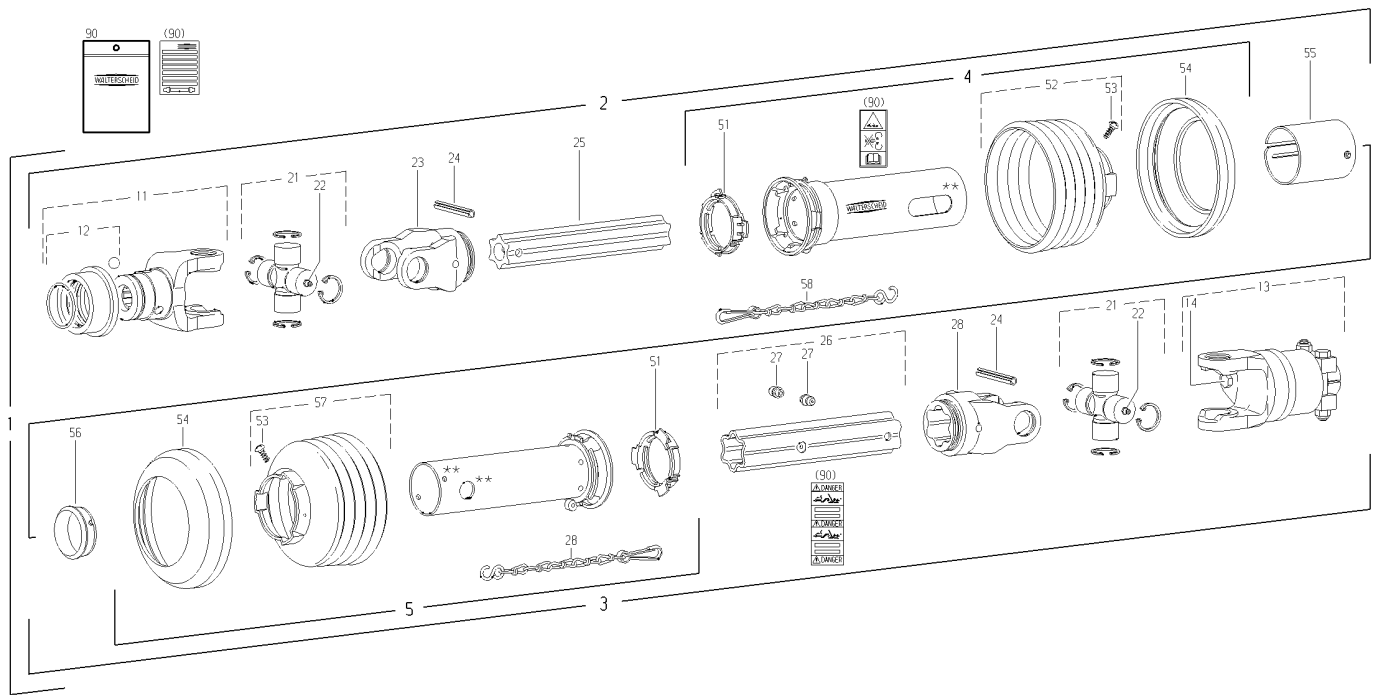

Item	Part No.	Description	Qty
1	607399	PTO drive shaft with guard	1
2		Inner PTO drive shaft half with outer guard half	1
3		Outer PTO drive shaft half with inner guard half	1
4	375627	Outer guard half	1
-		Shorten SC tube by 130 mm	
-		Shorten SC cone by 2 rib(s)	
5	375626	Inner guard half	1
-		Shorten SC tube by 325 mm	
-		Shorten SC cone by 1 rib(s)	
11	366800 (368302)	QSG-yoke complete QSG2500-1 3/8”(21)	1
12	376106	QSG-lock complete; size C	1
13	603849	Shear bolt clutch; right-hand rotation Shearing radius 56 mm	1
14	020454	Hexagon bolt	1
21	116405	Cross and bearing kit complete	2
22	153207	Drive-in type lubrication fitting	2
23	097133	Inboard yoke	1
24	304046	Spring-type straight pin	2
25	134941	Profile tube	1
-		Shorten tube by 35 mm	
26	696700	Profile tube with lubrication fitting	1
27	380371	Drive-in type lubrication fitting	2
28	097140	Inboard yoke	1
51	087276	Bearing ring	2
52	365388	Guard cone; n= Number of ribs	1
-		Shorten SC cone by 2 rib(s)	
53	365305	Screw	2
54	359471	Reinforcing collar	2
55	188064	Cover	1
56	158845	Bearing ring	1
57	365388	Guard cone; n= Number of ribs	1
-		Shorten SC cone by 1 rib(s)	
58	044321	Safety chain	2
90	118745	Instruction manual and WARNING decal	1
-			

PTO shaft (607400) 1-3/4"(20)

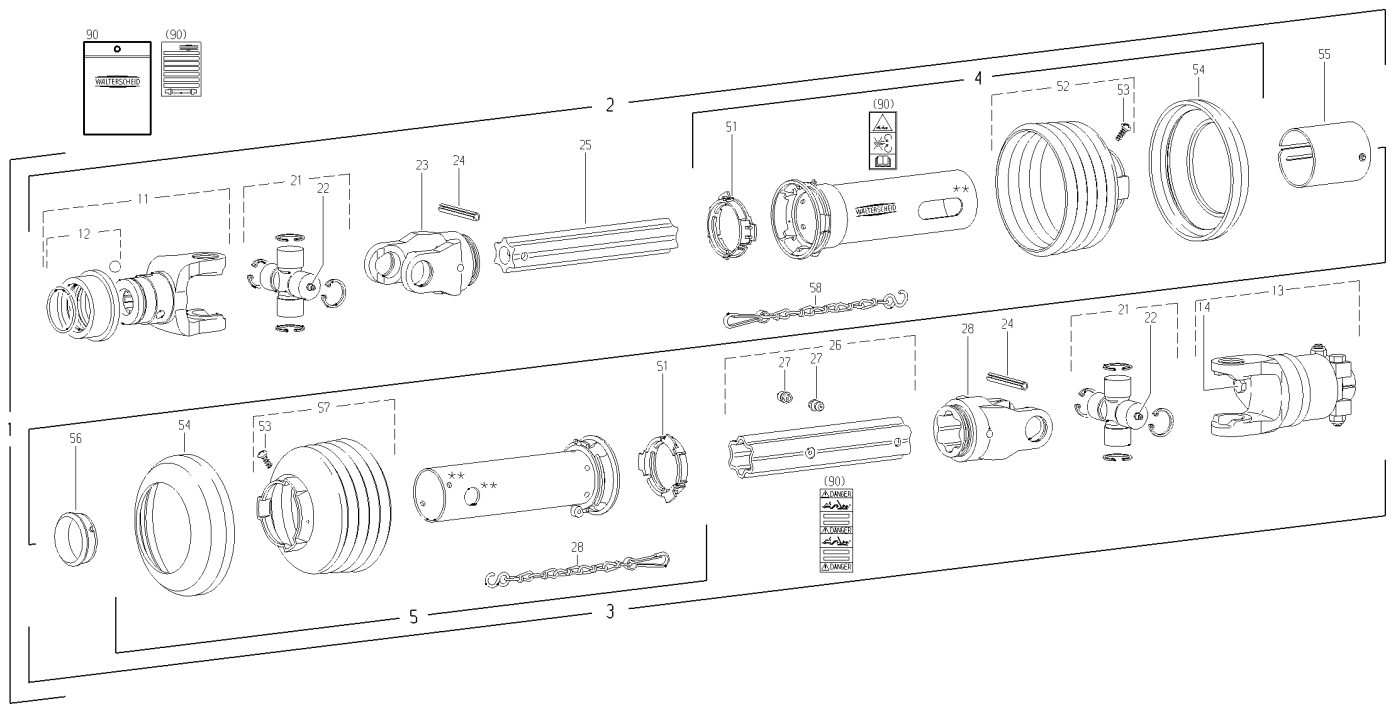

Item	Part No.	Description	Qty
1	607400	PTO drive shaft with guard	1
2		Inner PTO drive shaft half with outer guard half	1
3		Outer PTO drive shaft half with inner guard half	1
4	375627	Outer guard half	1
-		Shorten SC tube by 130 mm	
-		Shorten SC cone by 2 rib(s)	
5	375626	Inner guard half	1
-		Shorten SC tube by 325 mm	
-		Shorten SC cone by 1 rib(s)	
11	366808 (361802)	QSG-yoke complete QSG2500-1 3/4"(20)	1
12	376107	QSG-lock complete; size C	1
13	603849	Shear bolt clutch; right-hand rotation Shearing radius 56 mm	1
14	020454	Hexagon bolt	1
21	116405	Cross and bearing kit complete	2
22	153207	Drive-in type lubrication fitting	2
23	097133	Inboard yoke	1
24	304046	Spring-type straight pin	2
25	134941	Profile tube	1
-		Shorten tube by 35 mm	
26	696700	Profile tube with lubrication fitting	1
27	380371	Drive-in type lubrication fitting	2
28	097140	Inboard yoke	1
51	087276	Bearing ring	2
52	365388	Guard cone; n= Number of ribs	1
-		Shorten SC cone by 2 rib(s)	
53	365305	Screw	2
54	359471	Reinforcing collar	2
55	188064	Cover	1
56	158845	Bearing ring	1
57	365388	Guard cone; n= Number of ribs	1
-		Shorten SC cone by 1 rib(s)	
58	044321	Safety chain	2
90	118745	Instruction manual and WARNING decal	1
-		WARNING decal	

PTO shaft (604324)

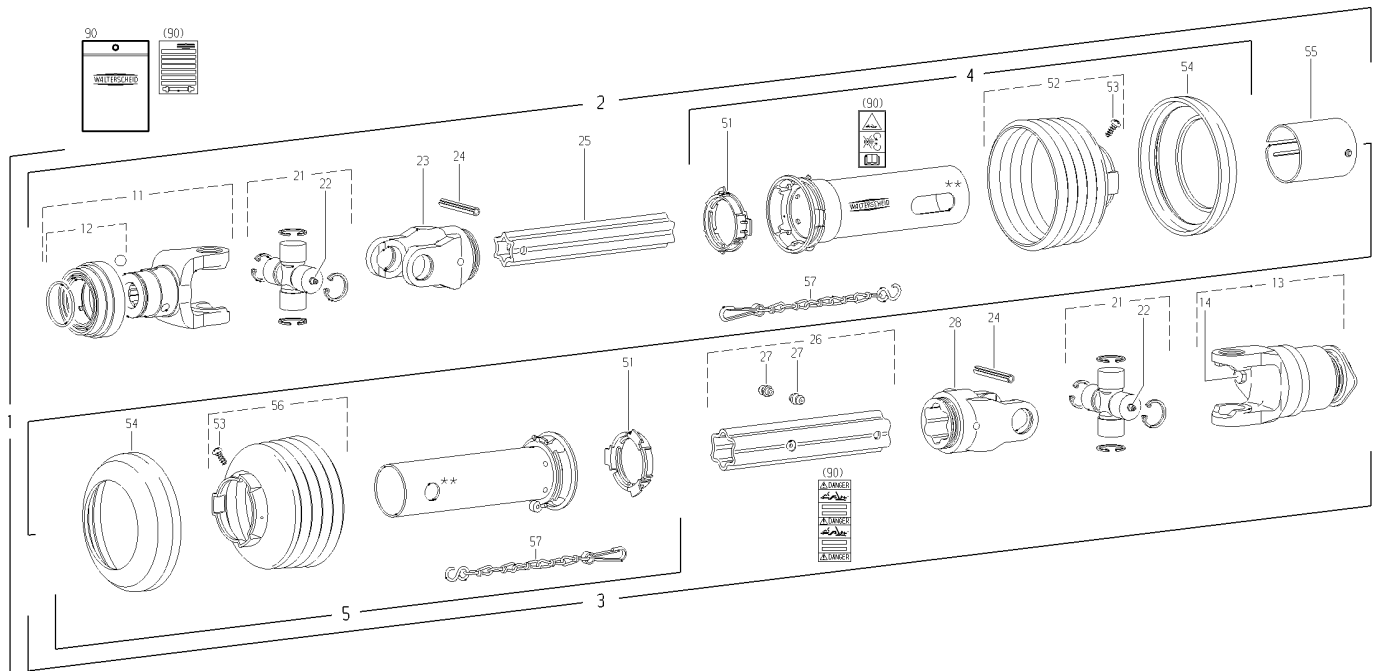

Item	Part No.	Description	Qty
1	604324	PTO drive shaft with guard	1
-			
2		Inner PTO drive shaft half with outer guard half	1
-			
3		Outer PTO drive shaft half with inner guard half	1
-			
4	375627	Outer guard half	1
-		Shorten SC tube by 430 mm	
-		Shorten SC cone by 2 rib(s)	
5	375626	Inner guard half	1
-		Shorten SC tube by 440 mm	
-		Shorten SC cone by 1 rib(s)	
11	366798	QSG-yoke complete	1
12	376105	QSG-lock complete; size B	1
13	121616	Shear bolt clutch;	1
-		right-hand rotation	
-		Shearing radius 56 mm	
14	020454	Hexagon bolt	1
21	116405	Cross and bearing kit complete	2
22	153207	Drive-in type lubrication fitting	2
23	097133	Inboard yoke	1
24	304046	Spring-type straight pin	2
25	134940	Profile tube	1
-		Shorten tube by 20 mm	
26	693676	Profile tube with lubrication fitting	1
27	380371	Drive-in type lubrication fitting	2
28	0974140	Inboard yoke	1
51	087276	Bearing ring	2
52	365388	Guard cone; n= Number of ribs	1
-		Shorten SC cone by 2 rib(s)	
53	365305	Screw	2
54	359471	Reinforcing collar	2
55	188064	Cover	1
56	365388	Guard cone; n= Number of ribs	1
-		Shorten SC cone by 1 rib(s)	
57	044321	Safety chain	2
90	118745	Instruction manual and warning	1

Chain strap

MJ30-630/560 (CYC-USLK40) (2 per machine)

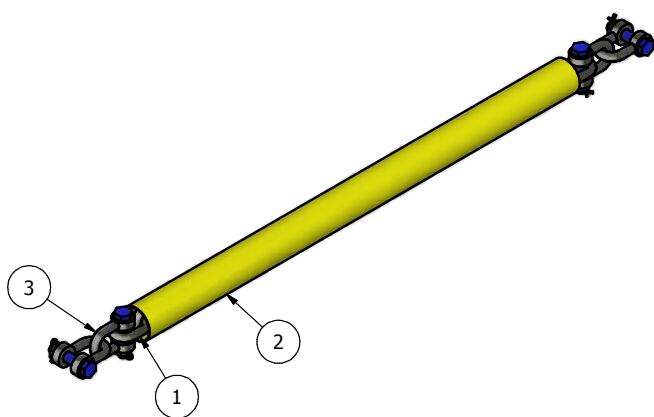

Item Part No.	Description	Qty
1 CYC-USLK42	16x48GR80 CHAIN	1
2 CYC-USLK43	COVER (50004025) YELLOW	1
3 DSR-5-8	5/8" RATED 'D' SHACKLE	4

2500CM-STRP01 (MJ30/31-420DW/280)

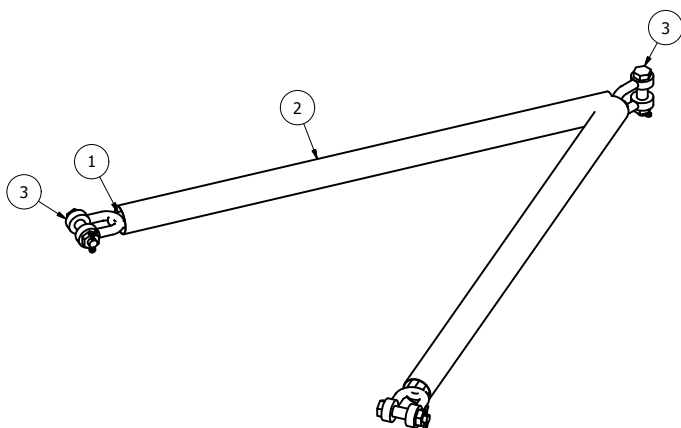

Item Part No.	Description	Qty
1 2500CM-STRP03	11mm LONG LINK CHAIN	2
2 2500CM-STRP02	COVER	2
3 DSR-5-8	5/8" RATED 'D' SHACKLE	3

MJ30 A-frame buffer (AFB-GA1)

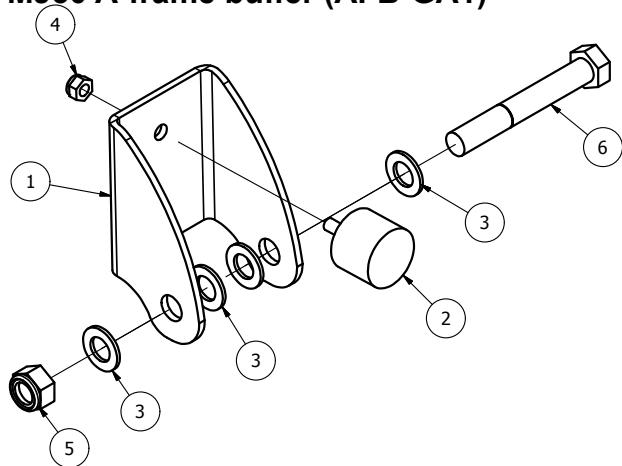

Item	Part No.	Description	Qty
1	AFB-MP	BUFFER MOUNT PLATE	1
2	53005802	DIA 50x40xM10 BUFFER	1
3	FWM20	M20 FLAT WASHER	4
4	M10	M10 NYLOC NUT	1
5	M20	M20 NYLOC NUT	1
6	M20x140BZP	M20x140 BOLT	1
7	M20x150BZP	M20x150 BOLT	1

Hydraulics setup MJ30-630/560/420DW

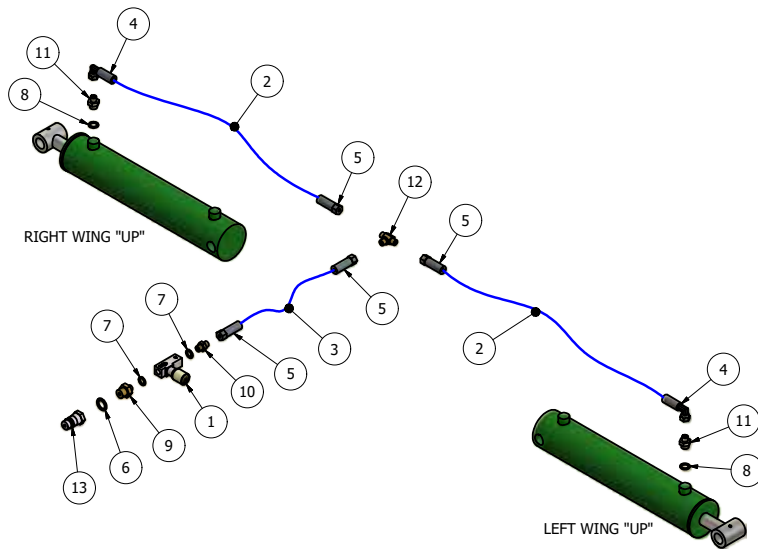

Item	Part No.	Description	Qty
1	1251-5-14	1/4" RESTRICTOR (BLACK) 204010V	1
2	350-HOSE A	1/4"x 1140mm Str to Block 90 (MJ30-560/420DW model)	2
2	350-HOSE A	1/4"x 1440mm Str to Block 90 (MJ30-630 model)	2
3	350-HOSE-B	1/4"x 2200mm Str to Str	1
4	CRP-1490B	1/4" CRIMP BLOCK 90	2
5	CRP1400	1/4" CRIMP (STRAIGHT)	4
6	EDOW12	1/2" DOWTY WASHER	1
7	EDOW14	1/4" DOWTY WASHER	2
8	EDOW38	3/8" DOWTY WASHER	2
9	EMM12-14	1/2"-1/4" M/M CONNECTOR	1
10	EMM14	1/4" M/M CONNECTOR	1
11	EMM3814	3/8-1/4" M/M CONNECTOR	2
12	EMMMT14	1/4" M/M/M CONNECTOR	1
13	QRM12	1/2" QUICK RELEASE MALE	1

Hydraulic Ram spares

Item	Part No.	Description	Qty
1	CY-420-WR-SK	SEAL KIT FOR MJ30-420 RAM	

NOTE: All threads hydraulic fittings and cylinders are BSPP (British Standard Parallel Pipe)

CAT 2 & 3 Quick hitch linkage setup (MJ30-630-BDGA1)

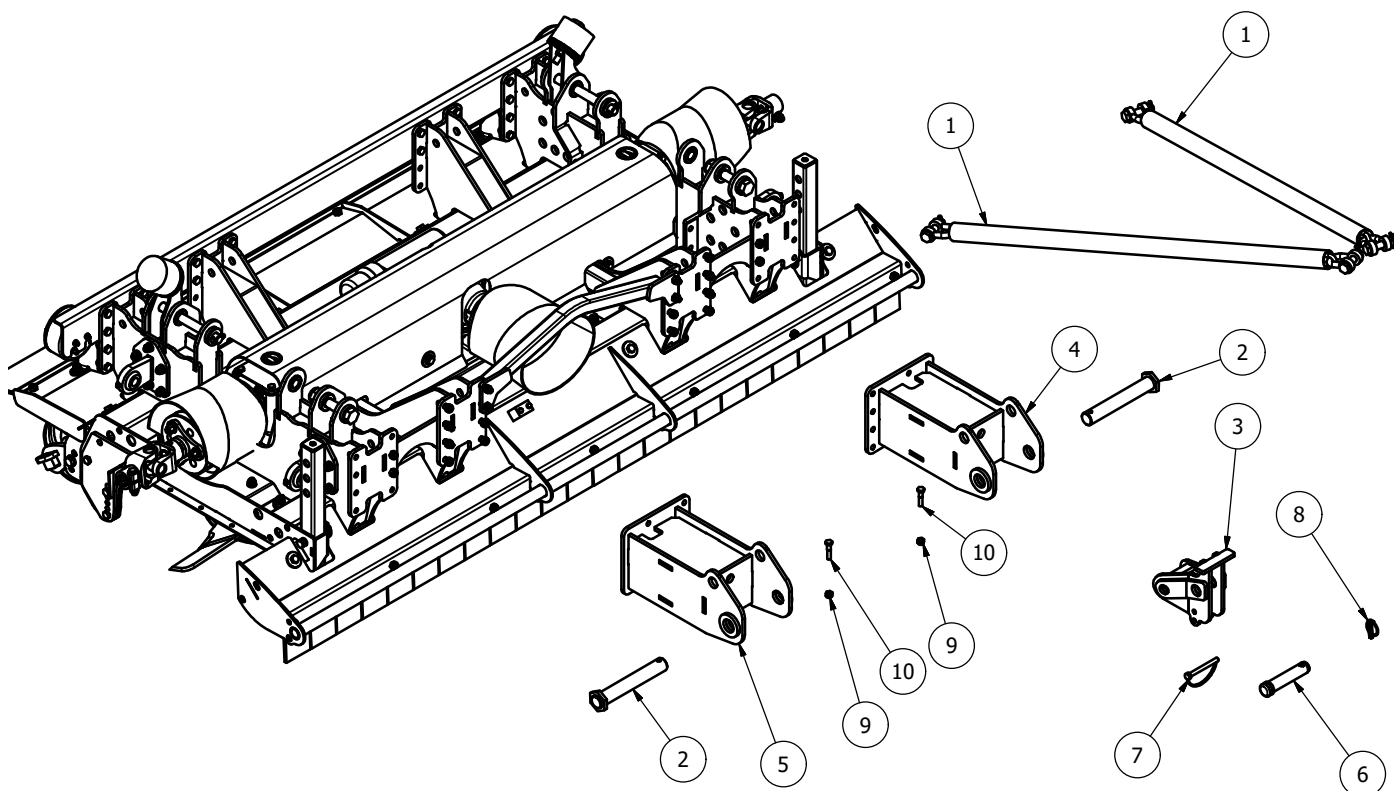

Item	Part No.	Description	Qty
1	CYC-USLK40	EXTENDED CHAIN SLING	2
2	CYC-USLK05	38mm LINKAGE PIN	2
3	CYC-USLK08	CHAIN MOUNT	1
4	CYC-USLK20	EXTENDED CAT 3 LINKAGE	1
5	CYC-USLK21	EXTENDED CAT 3 LINKAGE	1
6	3026	TOP LINK PIN (CAT 3, 32 x 125mm)	1
7	AG272	SHAFT LOCK PIN DIA 11	1
8	AN099/10	LINCH PIN DIA 9.5	1
9	M10	M10 NYLOC NUT	2
10	M10x50BZP	M10x50 BOLT	2

Wheel mounting bracket set (CYC-CW-WGKIT)

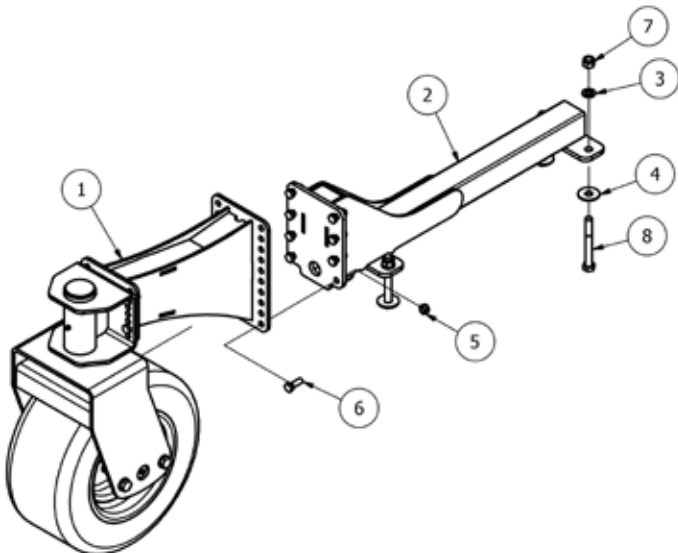

ITEM	PART NUMBER	DESCRIPTION	QTY
1	CYC-CW-01	CYCLONE CASTOR ASSY	1
2	CYC-CW-LK01	WING CASTOR MOUNT	1
3	FWM16	M16 FLAT WASHER	4
4	FWM16L	M16 FLAT WASHER (LARGE)	4
5	M12	M12 NYLOC NUT	8
6	M12x35BZP	M12x35 BOLT	8
7	M16	M16 NYLOC NUT	4
8	M16x130BZP	M16x130 BOLT	4

Wheel kit assembly (CYC-CW-01)

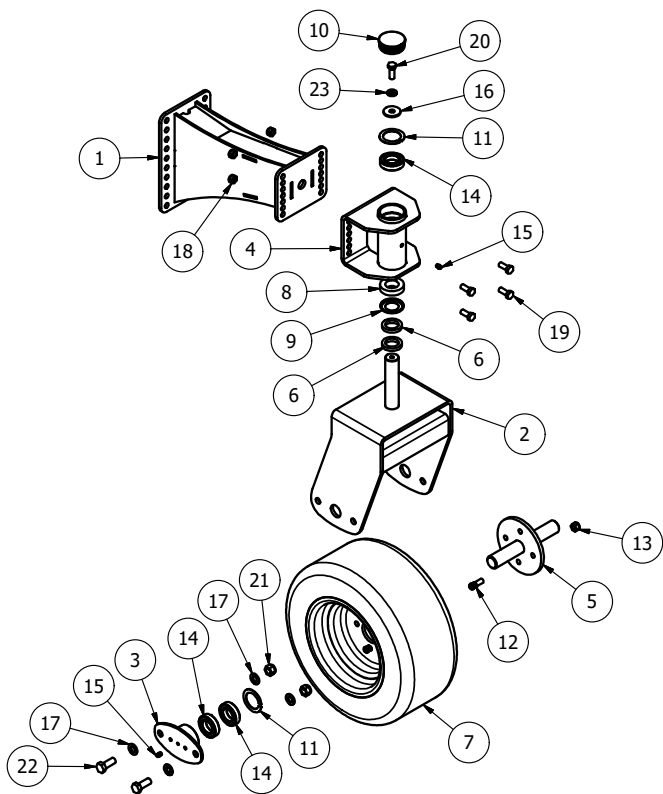

ITEM	PART NUMBER	DESCRIPTION	QTY
1	CYC-CW-10	CASTOR ARM	1
2	CYC-CW-20	CASTOR PIVOT FORK	1
3	CYC-CW-26	WHEEL BEARING HOUSE	2
4	CYC-CW-30	PIVOT BEARING HOUSING	1
5	CYC-CW-40	CASTOR AXLE	1
6	CYC-CW-35	SPACER WASHER	2
7	195/55RT	DIA 460x195mm	1
8	32007	TAPER BRG 62x35x18	1
9	32007XAV	NILOS RING 62x35	1
10	465601	DIA 61-64mm INSERT	1
11	55112	DIA 62 INT CIRCLIP	3
12	57112B1	M12 x 40 AXLE STUD	4
13	57312B1	M12 WHEEL NUT	4
14	6007RS	62x35x14 DEEP GROOVE	5
15	851	GREASE NIPPLE M8x1.25 STR	3
16	FWM12XL	M12 FLAT WASHER (EX-LARGE)	1
17	FWM16	M16 FLAT WASHER	8
18	M12	M12 NYLOC NUT	4
19	M12x30SZP	M12x30 SET BOLT	4
20	M12x35BZP	M12x35 BOLT	1
21	M16	M16 NYLOC NUT	4
22	M16x40SZP	M16x40 SET BOLT	4
23	NL12SP	M12 SP NORDLOCK	1

Blades

755-DCBLDHX2-L

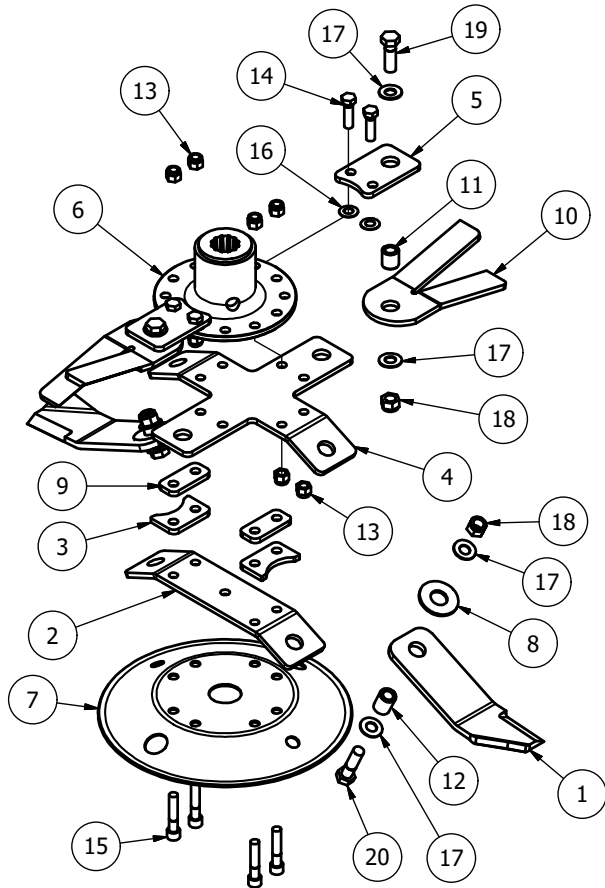

ITEM	PART NUMBER	DESCRIPTION	QTY
1	BLD-27020-10-AC	BLADE 270xDia 20 (Anti-Clk)	2
2	BLDB-294-25	BLADE BACK (294 CTR 25 deg)	1
3	BLDB-315-25-SY-STP1	BLADE STOP SPACER	2
4	BLDBX-315-25	CROSS BLADE BACK (315 CTR 25 deg)	1
5	BLDBXT-315-30	OVERLAPPER MOUNT	2
6	DF-BMP	J205 G/BOX BLADE MOUNT	1
7	DISC-315-25	DISC (315 BLADE 25 deg)	1
8	BLD-25025H-WSR4	4mmxDIA 26 BLADE WASHER	2
9	BLDB-315-25-SY2SP08	8mm SPACER	2
10	BLD-27025-OVL	DOUBLE EDGE OVERLAP BLADE	2
11	BB25-16-26	BLADE BUSH	2
12	BB25-16-32	BLADE BUSH	2
13	1/2F	1/2" FINE NYLOC NUT	8
14	12x134FBZP	1/2"x1 3/4" FINE BOLT	4
15	12x212FSKS	1/2"x2 1/2" FINE SOCKET HEAD 12.9	4
16	D281421	DISC SPRING 28x14.2x1.0	4
17	DSW34	DISC SPRING 34x16.3x2	8
18	M16	M16 NYLOC NUT	4
19	M16x50BZP	M16x50 BOLT	2
20	M16x60BZP	M16x60 BOLT	2

5 off MJ30-630
 4 off MJ30-560
 3 off MJ30-420DW

755-DCBLDHX2-R

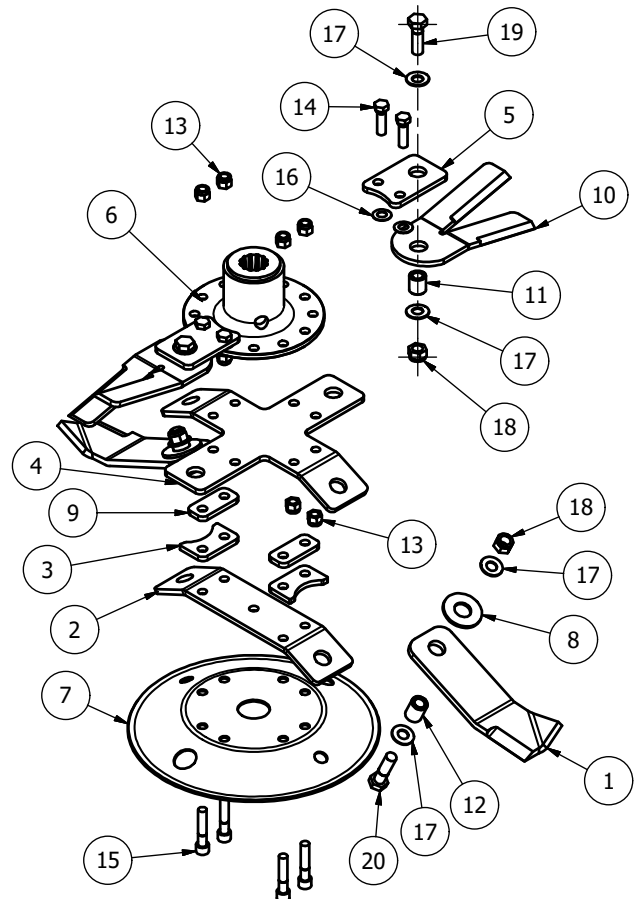

ITEM	PART NUMBER	DESCRIPTION	QTY
1	BLD-27020-10-C	BLADE 270xDia 20 (Clk)	2
2	BLDB-294-25	BLADE BACK (294 CTR 25 deg)	1
3	BLDB-315-25-SY-STP1	BLADE STOP SPACER	2
4	BLDBX-315-25	CROSS BLADE BACK (315 CTR 25 deg)	1
5	BLDBXT-315-30	OVERLAPPER MOUNT	2
6	DF-BMP	J205 G/BOX BLADE MOUNT	1
7	DISC-315-25	DISC (315 BLADE 25 deg)	1
8	BLD-25025H-WSR4	4mmxDIA 26 BLADE WASHER	2
9	BLDB-315-25-SY2SP08	8mm SPACER	2
10	BLD-27025-OVL	DOUBLE EDGE OVERLAP BLADE	2
11	BB25-16-26	BLADE BUSH	2
12	BB25-16-32	BLADE BUSH	2
13	1/2F	1/2" FINE NYLOC NUT	8
14	12x134FBZP	1/2"x1 3/4" FINE BOLT	4
15	12x212FSKS	1/2"x2 1/2" FINE SOCKET HEAD 12.9	4
16	D281421	DISC SPRING 28x14.2x1.0	4
17	DSW34	DISC SPRING 34x16.3x2	8
18	M16	M16 NYLOC NUT	4
19	M16x50BZP	M16x50 BOLT	2
20	M16x60BZP	M16x60 BOLT	2

4 off MJ30-630
 4 off MJ30-560
 3 off MJ30-420DW

755-DCBLDHTX5-L

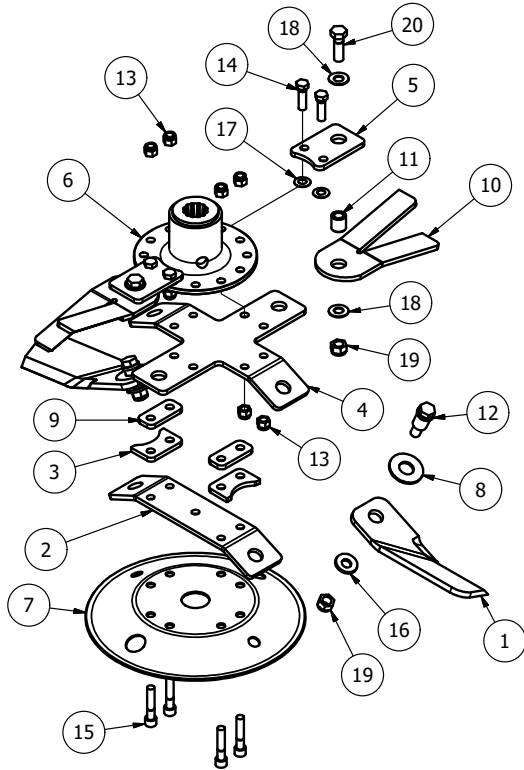

ITEM	PART NUMBER	DESCRIPTION	QTY
1	BLD-27025T-10AC	Twist Blade 270xDia 25 (Anti_Clk)	2
2	BLDB-294-25	BLADE BACK (294 CTR 25 deg)	1
3	BLDB-315-25-SY-STP1	BLADE STOP SPACER	2
4	BLDBX-315-25	CROSS BLADE BACK (315 CTR 25 deg)	1
5	BLDBXT-315-30	OVERLAPPER MOUNT	2
6	DF-BMP	J205 G/BOX BLADE MOUNT	1
7	DISC-315-25	DISC (315 BLADE 25 deg)	1
8	BLD-25025H-WSR4	4mmxDIA 26 BLADE WASHER	2
9	BLDB-315-25-SY2SP08	8mm SPACER	2
10	BLD-27025-OVL	DOUBLE EDGE OVERLAP BLADE	2
11	BB25-16-26	BLADE BUSH	2
12	BS2510-01	THREADED BUSH DIA 25	2
13	1/2F	1/2" FINE NYLOC NUT	8
14	12x134FBZP	1/2"x1 3/4" FINE BOLT	4
15	12x212FSKS	1/2"x2 1/2" FINE SOCKET HEAD 12.9	4
16	CW39174	DISC SPRING 39x17x4 (YELLOW)	2
17	D281421	DISC SPRING 28x14.2x1.0	4
18	DSW34	DISC SPRING 34x16.3x2	4
19	M16	M16 NYLOC NUT	4
20	M16x50BZP	M16x50 BOLT	2

2 off MJ31-280

755-DCBLDHTX5-R

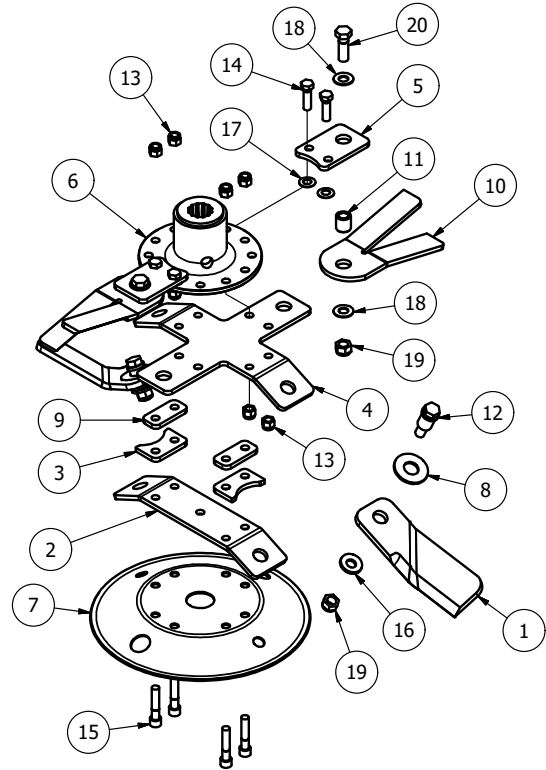

ITEM	PART NUMBER	DESCRIPTION	QTY
1	BLD-27025T-10C	Twist Blade 270xDia 25 (Clk)	2
2	BLDB-294-25	BLADE BACK (294 CTR 25 deg)	1
3	BLDB-315-25-SY-STP1	BLADE STOP SPACER	2
4	BLDBX-315-25	CROSS BLADE BACK (315 CTR 25 deg)	1
5	BLDBXT-315-30	OVERLAPPER MOUNT	2
6	DF-BMP	J205 G/BOX BLADE MOUNT	1
7	DISC-315-25	DISC (315 BLADE 25 deg)	1
8	BLD-25025H-WSR4	4mmxDIA 26 BLADE WASHER	2
9	BLDB-315-25-SY2SP08	8mm SPACER	2
10	BLD-27025-OVL	DOUBLE EDGE OVERLAP BLADE	2
11	BB25-16-26	BLADE BUSH	2
12	BS2510-01	THREADED BUSH DIA 25	2
13	1/2F	1/2" FINE NYLOC NUT	8
14	12x134FBZP	1/2"x1 3/4" FINE BOLT	4
15	12x212FSKS	1/2"x2 1/2" FINE SOCKET HEAD 12.9	4
16	CW39174	DISC SPRING 39x17x4 (YELLOW)	2
17	D281421	DISC SPRING 28x14.2x1.0	4
18	DSW34	DISC SPRING 34x16.3x2	4
19	M16	M16 NYLOC NUT	4
20	M16x50BZP	M16x50 BOLT	2

2 off MJ31-280

755-DCBLDHX5-L

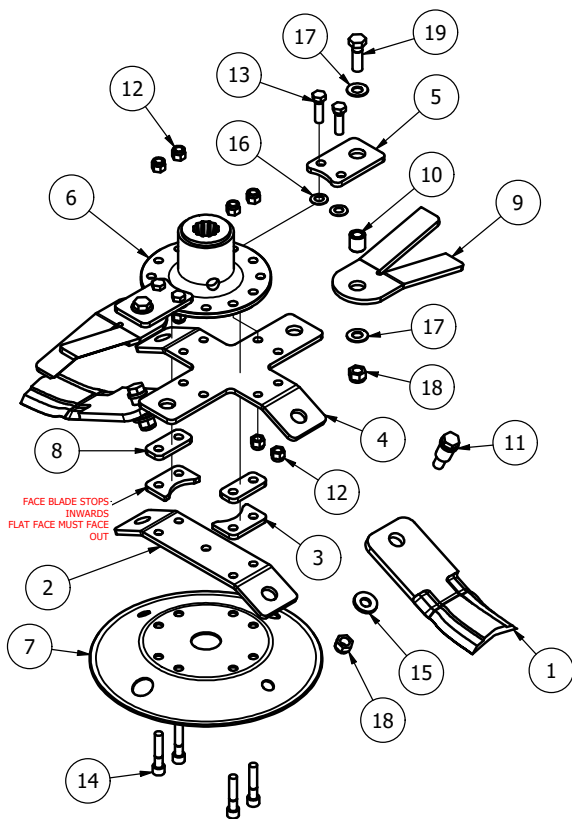

ITEM	PART NUMBER	DESCRIPTION	QTY
1	BLD-2702030DF	DOUBLE FOLD BLADE 270x20-30	2
2	BLDB-294-25	BLADE BACK (294 CTR 25 deg)	1
3	BLDB-315-25-SY-	BLADE STOP SPACER	2
4	BLDBX-315-25	CROSS BLADE BACK (315 CTR 25 deg)	1
5	BLDBXT-315-30	OVERLAPPER MOUNT	2
6	DF-BMP	J205 G/BOX BLADE MOUNT	1
7	DISC-315-25	DISC (315 BLADE 25 deg)	1
8	BLDB-315-25-SY2SP08	8mm SPACER	2
9	BLD-27025-OVL	DOUBLE EDGE OVERLAP BLADE	2
10	BB25-16-26	BLADE BUSH	2
11	BS2510-01	THREADED BUSH DIA 25	2
12	1/2F	1/2" FINE NYLOC NUT	8
13	12x134FBZP	1/2"x1 3/4" FINE BOLT	4
14	12x212FSKS	1/2"x2 1/2" FINE SOCKET HEAD 12.9	4
15	CW39174	DISC SPRING 39x17x4 (YELLOW)	2
16	D281421	DISC SPRING 28x14.2x1.0	4
17	DSW34	DISC SPRING 34x16.3x2	4
18	M16	M16 NYLOC NUT	4
19	M16x50BZP	M16x50 BOLT	2

5 off MJ30-630

4 off MJ30-560

755-DCBLDHX5-R

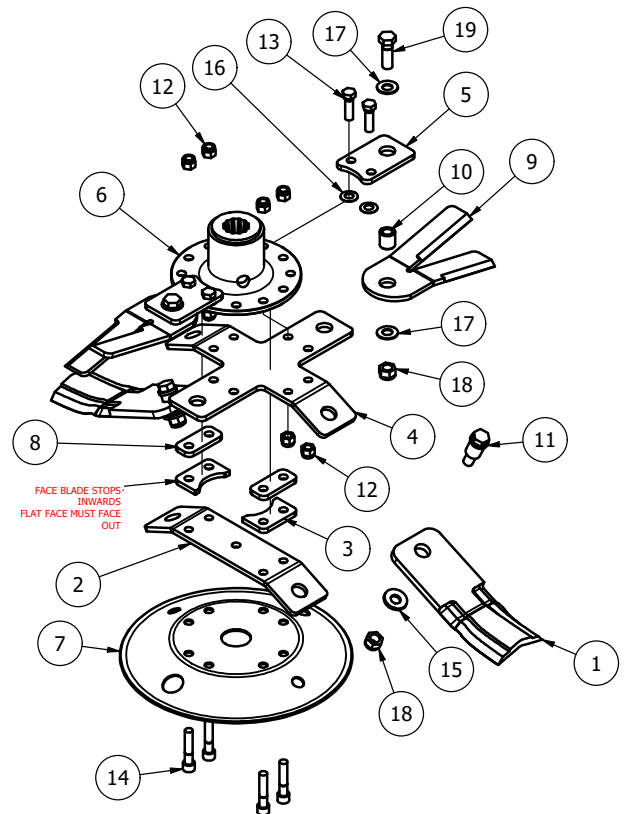

ITEM	PART NUMBER	DESCRIPTION	QTY
1	BLD-2702030DF	DOUBLE FOLD BLADE 270x20-30	2
2	BLDB-294-25	BLADE BACK (294 CTR 25 deg)	1
3	BLDB-315-25-SY-STP1	BLADE STOP SPACER	2
4	BLDBX-315-25	CROSS BLADE BACK (315 CTR 25 deg)	1
5	BLDBXT-315-30	OVERLAPPER MOUNT	2
6	DF-BMP	J205 G/BOX BLADE MOUNT	1
7	DISC-315-25	DISC (315 BLADE 25 deg)	1
8	BLDB-315-25-SY2SP08	8mm SPACER	2
9	BLD-27025-OVL	DOUBLE EDGE OVERLAP BLADE	2
10	BB25-16-26	BLADE BUSH	2
11	BS2510-01	THREADED BUSH DIA 25	2
12	1/2F	1/2" FINE NYLOC NUT	8
13	12x134FBZP	1/2"x1 3/4" FINE BOLT	4
14	12x212FSKS	1/2"x2 1/2" FINE SOCKET HEAD 12.9	4
15	CW39174	DISC SPRING 39x17x4 (YELLOW)	2
16	D281421	DISC SPRING 28x14.2x1.0	4
17	DSW34	DISC SPRING 34x16.3x2	4
18	M16	M16 NYLOC NUT	4
19	M16x50BZP	M16x50 BOLT	2

4 off MJ30-630

4 off MJ30-560

JJ.03499 (1.9 3W)

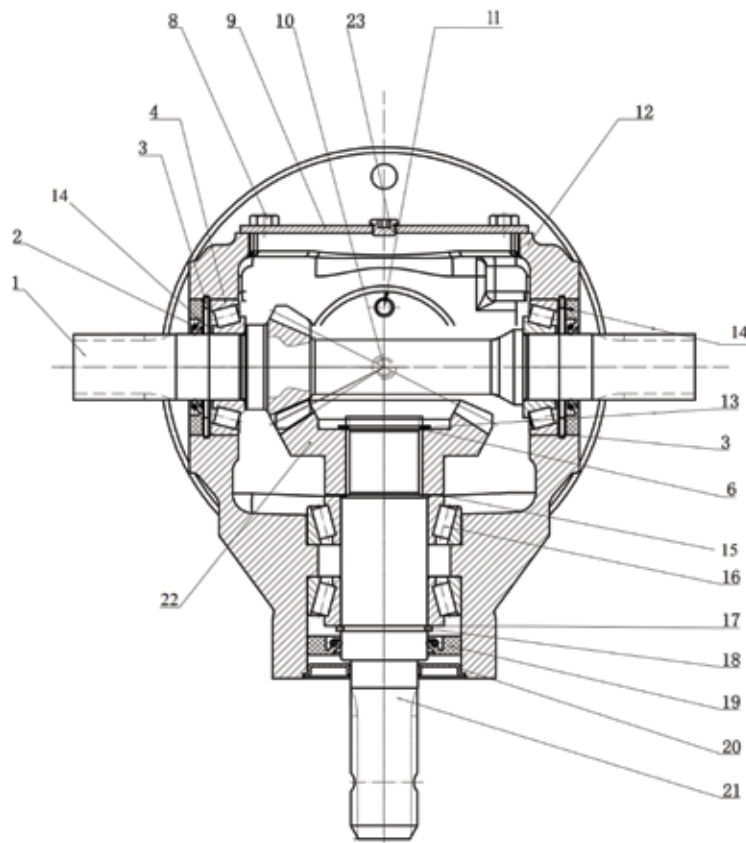

Item	Part No	Description	Qty
1	GB-03512-5001	output shaft	1
2	357207	double-lip seal 35x72x7	2
3	8.5.2.00131.00	circlip $\Phi 72 \times 2.5$	2
4	30207	tapered roller bearing 30207 (35x72x18.25)	2
6	0.240.7500	Adjusting washer (40.3x51.5)	
8	M8x16SZP	Hexagon bolt M8x16	4
9	GB-03512-1300	Cover	1
10	8.6.6.00088.00	Oil bung	1
11	8.6.7.00269	Oil breather bung	1
12	GB-03512-0300	housing	1
13	8.5.1.00029	circlip $\Phi 40 \times \Phi 37.5 \times 1.75$	1
14	0.248.7500	adjusting washer (60.3x71.7)	2
15	0.285.7500	adjusting washer(40.3x61.7)	
16	33109	tapered roller bearing 33109 (45x80x26)	2
17	0.175.7500	adjusting washer 45.2x54.8	
18	8.5.1.02368	Circlip $\Phi 45 \times 2.5$	1
19	8.7.1.00999	double-lip seal 45x80x10	1
20	GB-03512-7100	Protective washer	1
21	GB-03512-2000	Input shaft	1
22	GB-03512-6001	Bevel gear	1
23	9510.204.125	1/2 GAS oil plug+copper washer	1

MJ40T (347.801) (1.47)

MJ40T-S (347.801) (1.47 SHORT)

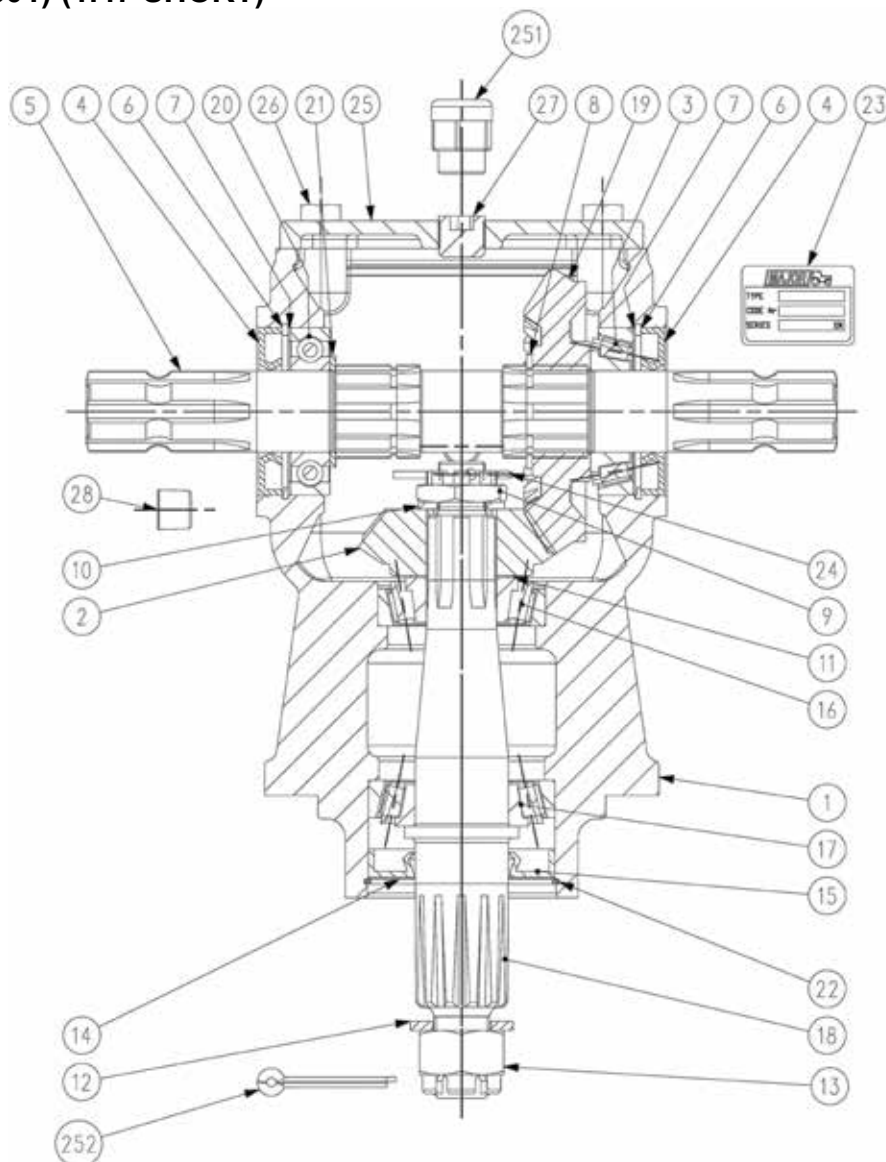

Item	Part No	Description	Qty
1	0.347.0300.00	Casting and Machining	1
2	U0.040.5004.00	Gear Pinion Z15 M5.5	1
3	8.0.9.00026	Roller Bearing 30207 (35x72x28.25)	1
4	8.7.3.00055	Oil Seal (35x72x10)	2
5	0.347.3000.00	Through Shaft 1"3/8 Z6 - 1"3/8 Z6	1
5		Short shaft for MJ40T-S	
6	8.5.2.00131	Snap Ring (72x75x2.5 , For Holes)	2
7	0.248.7500.00	Shim Kit (60.3x71.7)	2
8	8.5.1.00680	Snap Ring (40x37.5x2.5 , for shafts)	1
9	0.289.7102.02	Castle Nut (M20x1)	1
10	8.3.2.00531	Flat Washer (21x37x3)	1
11	0.102.7500.00	Shim kit (30.3x44)	1
12	LF135-2	Flat Washer (25x44x4)	1
13	LF135-1	Castle Nut (M24x2)	1
14	1.135.7100.00	Protective Flat Washer (40.4x79.9x1)	1

15	8.7.1.00748	Dust Lip (40x80x12)	1
16	8.0.9.01049	Roller Bearing 30306 (30x72x20.65)	1
17	8.0.9.00024	Roller Bearing 30208 (40x80x19.75)	1
18	U0.040.3006.01	Output Shaft ASA D.P. 8/16 Z12	1
19	U0.040.6004.00	Gear Crown Z22 M5.5	1
20	8.0.1.00870	Ball Bearing 6207 (35x72x17)	1
21	0.259.7525.00	Shim (35.5x48x2.5)	1
22	8.5.3.00955	Snap Ring SB 81 (81x82.8x2)	1
23	0.205.7100.00	"Major" Name Plate	1
24	8.4.7.00823	Cotter Pin (4x40)	1
25	0.347.1300.00	Top Cover	1
26	8.1.1.00061	Bolt M10x25 HHB (8.8)	4
27	8.6.6.00088	1/2" Gas Solid Plug	1
28	8.6.6.00201	3/8" Gas Oil Level Plug	1
251	8.6.7.00269	1/2" Gas Oil Breather Plug	1
252	8.4.7.00516	Cotter Pin (5x50)	1

266.207 (1.47 3W)
266.207-S (1.47 3W SHORT)

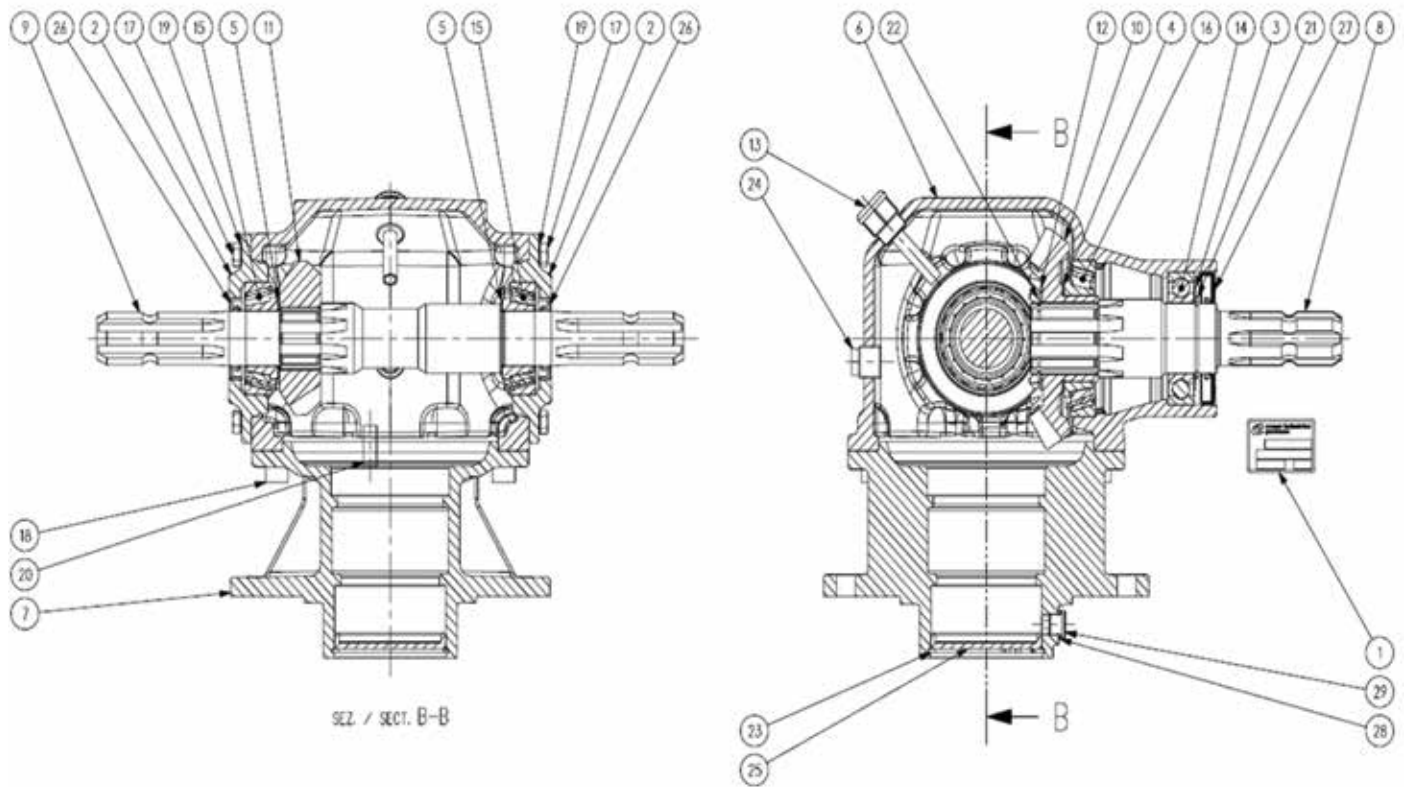

Item	Part No	Description	Qty
1	0.124.7101.00	PLATE "COMER"	1
2	0.248.1350.00	COVER	2
3	0.252.7500.00	SHIM KIT 45.3x65.3	1
4	0.257.7500.00	SHIM 55.3x67.7	1
5	0.259.7500.00	SHIM KIT 35.3x48.0	2
6	0.266.0300.00	CASING	1
7	0.266.1704.00	EXTENSION	1
8	0.266.2004.00	SHAFT 1"3/8 Z6	1
9	0.266.3206.00	SHAFT	1
9	0.266.3206.00-S	SHAFT (SHORT)	1
10	0.266.5003.00	CROWN WHEEL Z22 M6,3	1
11	0.266.6015.00	PINION Z15 M6,3	1
12	0.350.7500.00	SHIM KIT 46.3x65.3	1
13	0.814.7102.00	OIL FILLER PLUG	1
14	8.0.1.00345	BALL BEARING 6209	1
15	8.0.9.00127	TAPERED ROLLER BEARING 32207	2
16	8.0.9.00174	TAPER ROLLER BEARING 30211	1
17	8.1.1.00083	HHB BOLT M8x20 UNI5739 8.8	16
18	8.1.2.01641	HSHC SCREW UNI5931 M10x25 12.9 DCRT320	8
19	8.3.7.00140	SPRING WASHER 8,4X13X1,2	16
20	8.4.5.01036	SPRING PIN 10X26 D7343	2
21	8.5.1.00200	SNAP RING 45 UNI7435	1
22	8.5.1.00260	SNAP RING 46 UNI7435	1
23	8.5.2.00030	SNAP RING HOLE 80 UNI7437/DIN472	1
24	8.6.5.00203	PLUG 1/2"GAS	1
25	8.7.0.00790	CAP 80X10	1
26	8.7.1.00624	DOUBLE LIP SEAL 35X52 X7	2
27	8.7.1.02348	DUST LIP OIL SEAL 45X85X10	1
28	9440.316.300	COPPER WASHER 13,4X19X1,5 (1/4G)	1
29	9510.051.501	MAGNETIC PLUG 1/4 GAS DIN908	1

266.209 (1.47 4W)

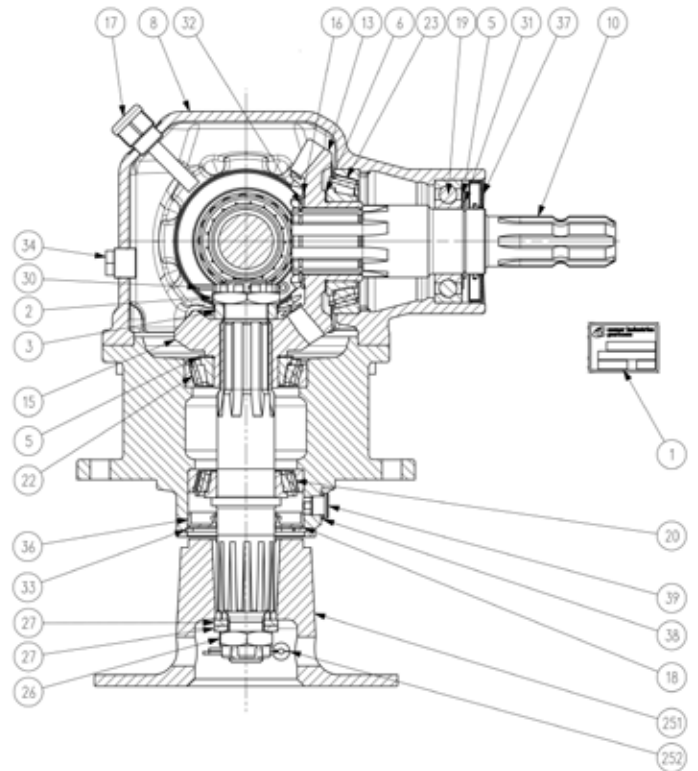
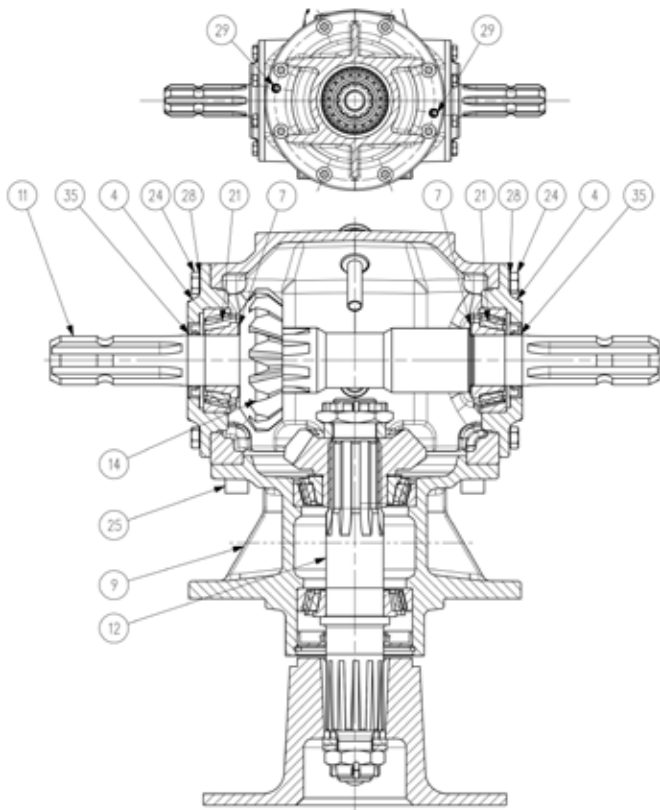

Item	Part No	Description	Qty
1	0.124.7101.00	Serial plate	1
2	0.132.7106.00	NUT M30X1.5	1
3	0.132.7109.00	SPACER 30.3x43x10.5	1
4	0.248.1350.00	COVER	2
5	0.252.7500.00	SHIM KIT 45.3x65.3	2
6	0.257.7500.00	SHIM 55.3x67.7	1
7	0.259.7500.00	SHIM KIT 35.3x48.0	2
8	0.266.0300.00	CASING	1
9	0.266.1704.00	EXTENSION	1
10	0.266.2004.00	SHAFT 1"3/8 Z6	1
11	0.266.3206.00	SHAFT 1"3/8 Z6	1
12	0.266.3207.00	SHAFT ASA 8/16 Z12	1
13	0.266.5003.00	CROWN WHEEL Z22 M6,3	1
14	0.266.6015.00	PINION Z15 M6,3	1
15	0.266.6016.00	PINION Z15 M6,3	1
16	0.350.7500.00	SHIM KIT 46.3x65.3	1
17	0.814.7102.00	OIL FILLER PLUG	1
18	1.135.7100.00	PROTECTIVE WASHER	1
19	8.0.1.00345	BALL BEARING 6209	1
20	8.0.9.00024	TAPERED ROLLER BEARING 30208	1
21	8.0.9.00127	TAPERED ROLLER BEARING 32207	2
22	8.0.9.00143	TAPERED ROLLER BEARING 30209	1
23	8.0.9.00174	TAPER ROLLER BEARING 30211	1
24	8.1.1.00083	HHB BOLT M8x20 UNI5739 8.8	16
25	8.1.2.01641	HSHC SCREW UNI5931 M10x25 12.9 DCRT320	8
26	8.2.2.01144	CASTLE NUT M24X2 PR80B	1
27	8.3.2.00409	BOLT WASHER 25X44X4	2
28	8.3.7.00140	WASHER "SCHNORR" 8,4x13x1,2	16
29	8.4.5.01036	SPRING PIN 10X26 D7343	2
30	8.4.7.01111	COTTER PIN B4X55	1
31	8.5.1.00200	SNAP RING 45 UNI7435	1
32	8.5.1.00260	SNAP RING 46 UNI7435	1
33	8.5.2.00030	SNAP RING HOLE 80 UNI7437 DIN472	1
34	8.6.5.00203	PLUG 1/2"GAS	1
35	8.7.1.00624	DOUBLE LIP SEAL 35X52 X7	2
36	8.7.1.02266	DOUBLE LIP SEAL 40X80X10	1
37	8.7.1.02348	DUST LIP OIL SEAL 45X85X10	1
38	9440.316.300	COPPER WASHER 13,4X19X1,5 (1/4G)A4	1
39	9510.051.501	MAGNETIC PLUG 1/4 GAS DIN908	1

All MAJOR machines must be registered when sold, to ensure that you receive the correct warranty cover and service bulletins. To register your machine for warranty, please go to the SALES & SUPPORT section of our website www.major-equipment.com and enter your details.

The Grass & Slurry Machinery Specialists | Agricultural - Professional Groundscare - Industrial

MAJOR

HOME PRODUCTS ABOUT NEWS FIND A DEALER SHOP SALES & SUPPORT CONTACT

How To Videos
Financing
Request a Demo
Technical Publications
Brochures
Register your Machine
Frequently Asked Questions

Register your Machine

Product Registration Form

Please register your machine to ensure you get the correct warranty cover and service bulletins. Please provide your full postal address.

Name * **Email ***

Address *

Address 1

Address 2



Get In Touch

Head Office

Major Equipment Intl Ltd

Ballyhaunis, Co. Mayo, F35 C891, Ireland

Tel: + 353 (0) 9496 30572

info@major-equipment.com

UK Office

Major Equipment Ltd

Major Ind. Estate, Heysham, Lancs, LA3 3JJ, UK

Tel: + 44 (0) 1524 850501

ukinfo@major-equipment.com

Netherlands Office

Major Equipment Intl Ltd (EU)

Postbus 29, NL-7700 AA Dedemsvaart, Nederland

Tel: + 31 (0) 6389 19585

euinfo@major-equipment.com

@MAJOREQUIPMENT



www.major-equipment.com