



800SM-HD, 900SM-HD
7FTGDX-HD, 9FTGDX-HD
909HD

Operator's Manual
and Parts List



WARNING

Read this instruction manual thoroughly before using your machine and follow all safety precautions.

www.major-equipment.com

Head Office

Major Equipment Intl. Ltd.
Ballyhaunis,
Co. Mayo,
Ireland.

Tel.: +353 (0) 9496 30572
Fax: +353 (0) 9496 30788
Email: info@major-equipment.com

UK Office

Major Equipment Ltd.
Major Industrial Estate,
Middleton Rd.,
Heysham,
Lancs.
LA3 3JJ

Tel.: +44 (0) 1524 850 501
Fax: +44 (0) 1524 850 502
Email: ukinfo@major-equipment.com

NETHERLANDS & GERMANY OFFICE

Major Equipment Intl. Ltd.
Postbus 29,
NL-7700 AA ,
Dedemsvaart,
Nederland.

Tel: +31 (0) 6389 19585
Email: euinfo@major-equipment.com

Web: www.major-equipment.com

@MAJOREQUIPMENT



Disclaimer

While every effort has been made in the production of this manual to ensure that the information contained herein is full and correct, Major assumes no responsibility for errors or omissions.

Major reserves the right to modify the machinery and the technical data contained within the manual without prior notice.

Further to this, Major assumes no liability for any damages which may result from the use of the information contained within this manual.

Contents

Introduction

Thank you	1
Safety Aspects	1
Intended use	1
Register Your Product and Warranty Online	1
Tractor Requirements	2

Safety

Hazards associated with operating Grass Cutting Machinery	2
Operating Safely	3
Workstation	4
Regulations for use of the transmission	4
PTO Shaft Safety	4
Driving Safely on Public Roads	5
Inspections before Use	6
Starting Regulations	6

Product Identification

Machine Serial Numbers	7
Product Specifications	7
EEC certificate of conformity for machines	8
Machine Safety Labels	9
Key to Main Parts	10
Blade Rotation	11
Blade system	12
Drive-line gearboxes	12

Operating the Machine

Machine Set up	13
Attaching machine to the Tractor	14
Transport Position	15
Adjusting the skids and cutting height	15
Wheel Assembly	15
Hydraulic Breakaway Adjustment	16
Operating the Machine/Mowing	16

Maintenance

Machine storage	17
PTO Shaft Maintenance	17
Transmission Bolts	18
Roller <i>(if applicable)</i>	18
Replacement of wear parts	18
Clearing out a blockage	18
Wing shafts alignment <i>(if applicable)</i>	18
Troubleshooting	19
Lubrication schedule	21

Spare Parts

7FTGDX-HD (709HD)	23
9FTGDX-HD	24
909HD	25
Wheel Option for 9FTGDX-HD and 909HD	26
Wheel Assembly (TWA-002)	27
Wheel Assembly (TWA-220)	27
800SM-HD	28
900SM-HD	30
800SM-HD Blades	33
900SM-HD, 9FTGDX-HD Blades	33
7FTGDX-HD Blades	34
909HD Blades	35
PTO Shafts	36
MJ40L-347.800-1.47	37
MJ40T-347.801-1.47	38
T27A - 267.245 - 1.92	39
T304 - 304.601 - 2.54	40
LF140J-140.886-1 (140.881)	41
T292B-292.005-1.47	42

Introduction

Thank you

We appreciate having you as a customer and wish you many years of safe and satisfied use of your machine.

Safety Aspects

This manual is an important part of your machine and should remain with the machine when you buy it. Reading your operator's manual will help you and others avoid personal injury or damage to the machine. Information given in this manual will provide the operator with the safest and most effective use of the machine. Only competent and skilled persons who have fully read and understood this operator's manual are allowed to operate this machine.

Sections in your operator's manual are placed in a specific order to help you understand all the safety messages so you can operate this machine safely. You can also use this manual to answer any specific operating or servicing questions.

Your manual contains special messages to bring attention to potential safety concerns, machine damage as well as helpful operating and servicing information. Please read all the information carefully to avoid injury and machine damage. Should any questions arise regarding the information given in this booklet, please contact your local MAJOR dealer or MAJOR.

The operator is solely responsible for the safe use and maintenance of the machine. The machine must only be operated by a competent and skilled person. Setting up and adjustment must only be carried by the operator. Do not let a third party person to adjust or modify the machine in any way.

Intended use

This machine is a grass cutting machine and designed for cutting grass. Moreover, it must only be used with a suitable tractor (see "Product Specifications" section of this booklet) and driven by an adequate drive-line of the tractor PTO. All other use is strictly prohibited. Major will not be held responsible for any loss or damage caused due to a misuse of the machine.

Register Your Product and Warranty Online

To register your product through the Internet, simply go to the Support section on www.major-equipment.com. Completing the information, either online or with the product warranty card, will ensure the customer that their product receives all post sales service and important product information.

This machine is warranted for 12 months. No warranty is given where the machine is being used as a hire machine. Warranty is against faulty workmanship or parts.

Warranty covers parts only. All parts must be returned to the manufacturer. No warranty can be considered unless parts are returned. All replacement parts will be supplied on a chargeable basis until warranty has been accepted.

Tractor Requirements



Attaching the machine to the tractor will influence the stability and manoeuvrability of the tractor. Please consult your tractor manual for limitations on weight and towing ability of the tractor.

It is the operator's responsibility to ensure that the tractor is suitable for the machine. Always consult your tractor's manual for any further information required.

Recommended Horse Power requirements for the particular models are provided in the "Product Specification" section of this booklet. Using excessive power can affect the quality of cut and/or may damage the machine.

Tractors which are not suitable for the operation can sustain damage due to the weight and power requirements of the machine. Always observe the weight of machine provided in the "Product Specification" section of this booklet, compare this with the guidelines from the tractor manual and ensure that the tractor can lift the machine safely.

The machine is designed to be attached by means of a 2/3 point linkage connection or can be trailed (specific models). The position of the machine can be adjusted by manual or hydraulic top link.

Winged models require at least one hydraulic spool with 1/2" female quick release connection for a single acting ram/rams.

Road light kit requires a 12V 7 pin socket.

Safety

The operator's manual also explains any potential safety hazards whenever necessary in special safety messages that are identified with the word, CAUTION, and the safety-alert symbol .

Hazards associated with operating Grass Cutting Machinery

Shear Hazard

Shear hazards are created when the edges of two objects move toward or next to each other closely enough to cut relatively soft material. This can include the parts of the machine under hydraulic control when operating from transport to mowing position. Note, the wing units are designed to float independently of the centre deck & are free to move within operating limits.

Crush Hazard

Bystanders can be injured when machine is lowered into mowing position. Winged machines have crush points around the hinge areas & between the wing & main body. Always use transport locking bars when not in use (winged models only).

Rotating Blade Hazard

All persons are at risk if they place their hands or feet under the machine when it is raised from the ground when the blades are in motion.

Pinch Hazard

Pinch points are created when two objects move together, with at least one of them moving in a circle. This hazard is common in power transmission devices such as Belt Drives, Gear Drives & Rollers. Ensure all guarding is present.

Wrap Hazard

Any exposed, rotating machine component is a potential wrap point. Injuries usually occur when loose clothing or long hair catch on and wrap around rotating parts such as PTO shafts or Drive shafts on the machine. Ensure all guarding is present.

Free-wheeling parts Hazard

The heavier a revolving part is, the longer it will continue to rotate after power is shut off. This characteristic is called 'free-wheeling.' Blades, and various other components, drive shafts etc., will continue to move after power is shut off - often for several minutes. Injuries occur when:

- Operators shut off equipment, and attempt to clean or adjust a machine before components have completely stopped moving.
- Shear bolt protection device in PTO shaft shears & the mowing parts are still spinning but the primary PTO shaft is stationary. Operator awareness is the key to safety around freewheeling parts. Never raise the machine while the blades are still rotating.

Thrown objects Hazard

Machines throw material as a natural part of doing their job. Foreign objects, such as stones, sticks and other debris, may be taken into this equipment and expelled at tremendous speed. These objects are contained by the sides of the machine and by the rear/front rollers / guards / chain guards / rubber skirts depending on model of your machine. Ensure bystanders are clear from the machine & cannot be hit with debris expelled from the machine. Bystanders or animals in the path of thrown objects could be seriously injured. Never operate machine with decks raised from the ground as this makes the front/rear protection redundant.

Hydraulic Hazard (if applicable)

Hydraulic systems store considerable energy. Careless servicing, adjustment, or replacement of parts can result in serious injury. High pressure blasts of hydraulic oil can injure eyes or other body parts. The following precautions are crucial:

- Make certain the hydraulic pump is turned off.
- Lower attached equipment to the ground.
- Confirm that load pressure is off the system.

A pinhole leak in an hydraulic hose is a serious hazard. A leak may not be visible, and the only sign may be a few drops of fluid. Never inspect hydraulic hoses with your hands, because a fine jet of hydraulic fluid can pierce the skin.

Slips, Trips and Falls Hazard

Slips and falls often result from:

1. Slippery footing on the ground
2. Cluttered steps and work platforms.

The potential for slips and falls can be greatly reduced by using good judgement and practicing good housekeeping on and around equipment.

Noise Hazard

Please note that the machine is normally used outdoors and that the position of the operator is seated in the driving seat of the tractor. It is advisable to consult the prescriptions listed in tractor operator and maintenance manuals.

The acoustic pressure at a distance of 2.6m from the centre of the machine and at a height of 2.0m, with the implement operating in a no load condition can reach 90 dBA. In a loaded condition & a PTO rate of 540 (1000) RPM the value can reach 97dBA. Higher rate of PTO input will result in higher noise levels. Always wear hearing protection.

Operating Safely

This MAJOR machine is designed to operate at a PTO rate which is stated in the Product Specifications part of this booklet. Ensure tractor PTO output is set at a correct RPM rate. This MAJOR machine must only be used for purposes outlined in the Intended Use section of this booklet. All other use is strictly prohibited.



Users should become thoroughly familiar with the contents of this manual before using, servicing and mounting the implement to the tractor and all other pertinent operations. Never wear jewellery, loose clothing such as ties, scarves, belts, unbuttoned jackets or dungarees with open zips which could become caught up in moving parts.



Always wear approved garments complying with accident prevention provisions such as non-slip shoes, ear muffs, goggles and gauntlets. Wear a jacket with reflecting stickers if the implement is used near public highways.



Consult your retailer, the Labour Health Service or your nearest equivalent authority for the information about the current safety provisions and specific regulations with in order to ensure personal safety.



ALWAYS DISENGAGE PTO, SWITCH OFF THE TRACTOR ENGINE AND ENGAGE THE PARKING BRAKE BEFORE MAKING ADJUSTMENT TO THE MACHINE.



NEVER PLACE LIMBS UNDER THE MACHINE WHILE ROTOR(S) ARE TURNING. ROTOR(S) CAN REMAIN TURNING FOR UP TO 1 MINUTE AFTER DISENGAGING PTO.

Workstation

The operator must remain seated while working the machine. If the machine is a winged unit and the wings need to be raised/lowered the operator must not leave the tractor. Always ensure the PTO has been turned off and the parking brake applied before leaving the tractor cab or carrying out maintenance.



NEVER OPERATE THE HYDRAULICS WITH THE TRACTOR SWITCHED OFF

Regulations for use of the transmission

The transmission to the gearboxes is protected throughout the machine by both PTO shafts and bolt down covers. All guarding should be kept efficient and in good condition. If the condition is poor, the guarding should be renewed before the implement is used.



UNLESS IT IS CORRECTLY PROTECTED THE TRANSMISSION COULD CAUSE DEATH SINCE IT CAN CATCH ON PARTS OF THE BODY OR CLOTHING

Ensure retaining chains are correctly anchored on all PTO shafts, preventing them from turning. Ensure drive line can turn easily within the shield. Keep spline grooves clean and greased so that PTO shaft can connect easily. Besides being described in this booklet, the method by which the PTO shaft is connected to the tractor must be checked out with the instructions in the tractor manufacturer's manual.

PTO Shaft Safety

Maximum PTO input is specified in the Product Specifications section of this booklet. Contact your nearest dealer or a specialised retail outlet if the PTO must be replaced with a longer one, since this must belong to the same power category and possess the same characteristics. An unsuitable PTO could easily break.

The tractor PTO shaft length may be altered to suit the individual tractor model. When the machine is in operation, the PTO shaft should have a minimum 1/3 engagement as shown in the diagrams. After the machine has been hitched to the tractor, it should be checked in various positions that the drive line is the correct length. If the PTO is too short and tends to slip out of place, it must be replaced with a longer one.

If the PTO shaft is too long, it should be shortened in the following way:

- Set the machine at a minimum distance from the tractor, then brake the tractor and switch off the engine.
- Separate the two halves of the PTO. Insert the female part into the tractor PTO and the male part into the machine PTO, checking that the position is correct by means of the fixing pins.
- Line up the two halves of the PTO together, keeping them parallel.
- Using a felt tip pen, match mark the place where the two halves must be shortened as shown.
- First cut shield "1" and use part "2" as a reference to cut the splined shaft.
- Proceed in the same way for the second half.
- Trim and chamfer the two cut ends of the PTO and clean off all swarf and shavings.
- Grease the two profiles and join the two halves of the PTO together.
- Mount the PTO shaft and check that its length is correct as before.

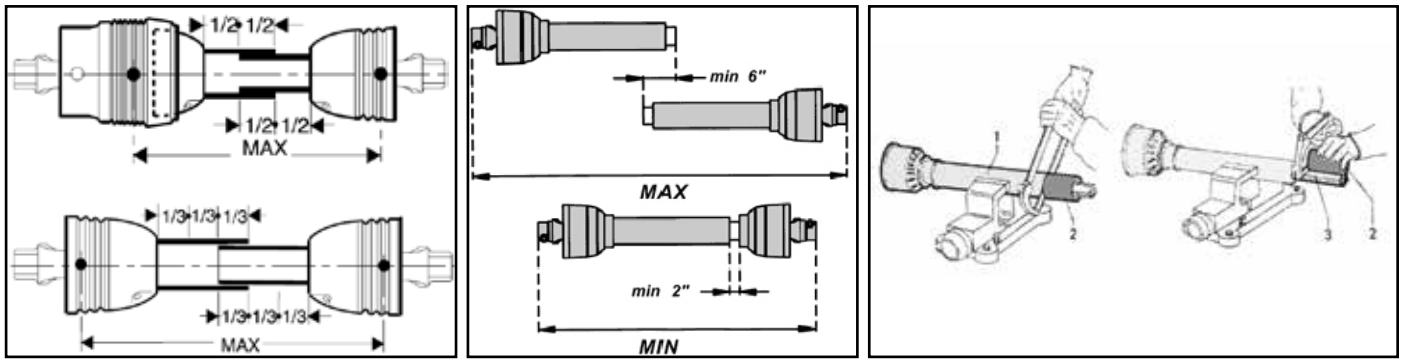

Driving Safely on Public Roads

Check the local Highway Code regulations before driving the tractor on public highways with an implement attached. Check the reflectors, hazard flashers and/or projecting load indicators are installed when required and efficient. These indicators must be installed correctly and easily seen by the drivers of other vehicles.

Bystanders must not be allowed to lean against or climb onto the machine during transport or while working. Do not allow bystanders to ride on the machine.



Maximum transport speed of the implement is limited to 25-30km/h depending on the model of the machine (observe safety labels on the machine).

Trailed Machines only (if applicable)

The shaft must not reach the end of the tube or project from this. Ensure the PTO does not bottom when turning

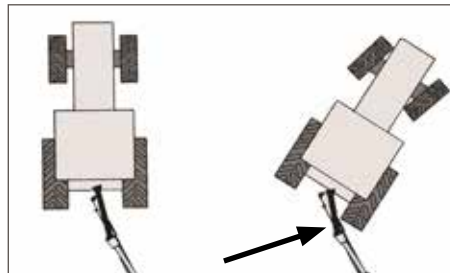

General safety instructions

Precautions to be taken while working with the machine:

1. Do not operate the machine when you are tired or under the influence of alcohol or any other intoxicant;
2. Before starting mowing, make sure that the area is clear of people or animals.
3. Before starting adjusting the machine, it is mandatory to disconnect the PTO, to turn off the engine of the tractor, apply handbrake and wait for the turning parts to become still and placed on the ground.
4. It is mandatory to read all the safety requirements and the operator's manual of the machine.
5. If you are not sure how to use the machine, please contact the manufacturer or the dealer.

Inspections before Use



Always disengage PTO, Switch off tractor engine and engage the parking brake before making adjustments to the machine.

1. With the whole machine as level as possible, check the oil level in all gearboxes. Top up if required through the oil filler plug. The correct level is at the oil level plug.
2. Grease all lubrication points as outlined in the Maintenance section of this booklet.
3. Check parts for wear.
4. Check the blade mounting bolts are tight.
5. Ensure the gearbox shaft nuts are tight and retained in place by split pin.
6. Check tightness of all nuts, bolts and pins.
7. Ensure safety guards and flaps are in place at all times where fitted. If these become worn or missing, replace them immediately with new ones.
8. Due to the corrosive nature of grass when cut, wash down the machine when finished mowing, especially when the machine is being stored for a long period of time.

Starting Regulations



Always check that any imminently dangerous conditions have been eliminated before using the machine. Ensure all guarding is present & the operator is fully aware of the operations of the machine.



Always ensure the pins lock the PTO shaft yoke ends onto the spline shafts on both the tractor and the implement. An unlocked shaft could slip out of position, causing notable mechanical damage and serious injury to both operator and bystanders.

Product Identification

Machine Serial Numbers

If you need to contact MAJOR or your MAJOR dealer for information on servicing or spare parts, always provide the product model and serial numbers. Model and Serial number can be found on the Serial Plate located on the machine.

We suggest that you record your machine details below:

Model No: _____

Serial No: _____

Date of Purchase: _____

Dealer Name: _____

Dealer Telephone: _____



Product Specifications

The machine is propelled by using a 6 spline 1-3/8" PTO shaft (provided with the machine).

Model	9FTGDX-HD	7FTGDX-HD	909 HD	800SM-HD	900SM-HD
Overall Width	2.74m (8' 9")	2.30m (7' 8")	2.91m (9' 5")	4.4m (14' 4")	4.5m (14' 7")
Cut Width	2.7m (9')	2.10m (7')	2.7m (9')	2.4m (8')	2.7m (9')
Transport Width	2.91m (9' 5")	2.30m (7' 8")	2.91m (9' 5")	2.22m (7' 3")	2.22m (7' 3")
No. of Blades	8	8	8	8	8
No. of Rotors	2	2	2	2	2
Power (HP)	40-90	40-70	50-110	35-80	50-90
PTO (rpm)	540	540	1000	540	540
Blade Speed	111m/s	87m/s	111m/s	100m/s	111m/s
Cutting Height	50-250mm	50-250mm	50-250mm	50-250mm	50-250mm
Weight (kg)	490kg (570kg with wheels)	450kg (530kg with wheels)	560kg (640kg with wheels)	550kg	640kg

EEC certificate of conformity for machines

(conforming to Directive 2006/42/EC)

Name of Manufacturer: Major Equipment Ltd
Address: Coolnaha, Ballyhaunis, Co. Mayo, Rep of Ireland

Tel. +353949630572
Fax +353949630788

declares in sole responsibility that the product:

Machine description and function: Rotary mower with vertical axes cutting heads which cuts grass so it can be subsequently picked up.

Model: GRASS TOPPER

Type: _____

Serial number: _____

Technical file compiled by: Alex Kolchanov (c/o Major Equipment Ltd)

- **THE SUPPLY OF MACHINERY (SAFETY) REGULATIONS 2008.**
- **S.I. No. 299 of 2007**, Safety, Health and Welfare at Work (General Application) Regulations 2007 (Ireland).
- **Health & Safety at Work, etc. Act 1974 (c.37) (UK).**
- **EN ISO 14121-1: 2007** 'Safety of machinery. Principles for risk assessment'.
- **EN 745** - Agricultural Machinery - Rotary Mowers and Flail Mowers - Safety.
- **EN ISO 13857** - Safety of machinery: Safety distances to prevent hazard zones being reached by upper and lower limbs.

I hereby certify on behalf of Major Equipment Int. Ltd., that this machine when properly installed and operated correctly, complies with all the essential Health & Safety requirements of all legislation referred to above.

Signed: 
Date: 14/11/2018
Name: John Murphy
Position: Managing Director

Place: Coolnaha, Ballyhaunis, Co. Mayo, Rep of Ireland

Machine Safety Labels

The machine safety labels shown in this section are placed in important areas on your machine to draw attention to potential safety hazards.

On your machine safety labels, the words DANGER, WARNING, and CAUTION are used with this safety alert symbol. DANGER identifies the most serious hazards.

To prevent Serious Injury or Death

- Avoid unsafe operation or maintenance.
- Do not operate or work on this machine without reading and understanding the operator's manual.
- If manual is lost, contact your nearest dealer for a new manual.



To avoid injury, read the manual

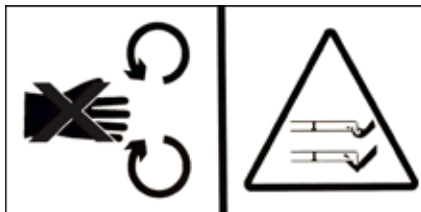

Rotating blade hazard



PTO entanglement hazard - keep clear of PTO drives.

WARNING



DO NOT GO NEAR LEAKS

- High pressure oil easily punctures skin causing serious injury, gangrene or death.
- If injured, seek emergency medical help. Immediate surgery is required to remove oil.
- Do not use finger or skin to check for leaks.
- Lower load or relieve hydraulic pressure before loosening fittings.

High oil pressure hazard

ATTENTION!!

CHECK TIGHTNESS OF TRANSMISSION BOLTS AT EVERY SERVICE.

Check tightness of the transmission bolts

ATTENTION!

Do not engage drive while in transport position

Do not engage drive while in transport position



Grease points

<p>MAX PTO INPUT 540 RPM</p> <p>© MAX. DREHZAHL 540 U/MIN © MAX. TORRENTIAL 540 TPM © MAX. PRISE DE FORCE 540 TOURS/MIN</p>	<p>MAX PTO INPUT 1000 RPM</p> <p>© MAX. DREHZAHL 1000 U/MIN © MAX. TORRENTIAL 1000 TPM © MAX. PRISE DE FORCE 1000 TOURS/MIN</p>
--	--

Maximum PTO input

Key to Main Parts

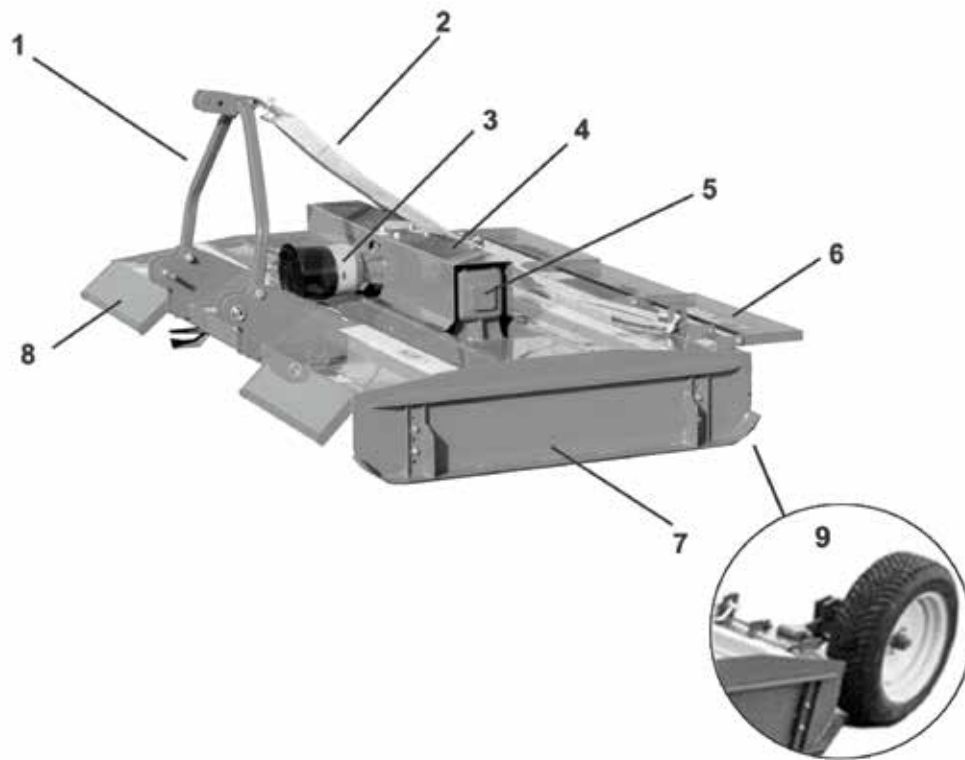

1	A Frame
2	Strap
3	PTO guard
4	Gearbox cover
5	Rotor gearbox
6	Back guard
7	Skid
8	Front guard
9	Wheel option 909HD & 9FTGDX-HD

1	Hydraulic ram
2	Float
3	Headstock
4	Transport locking pin (in transport)
5	Carrying arm
6	Gearbox cover
7	Rotor gearbox
8	Front guard
9	Skid
10	Rear guard
11	Secondary shaft
12	PTO guard
13	Transport locking pin (when mowing)
14	Hydraulic hoses
15	Skid
16	Long damper spring
17	Short damper spring

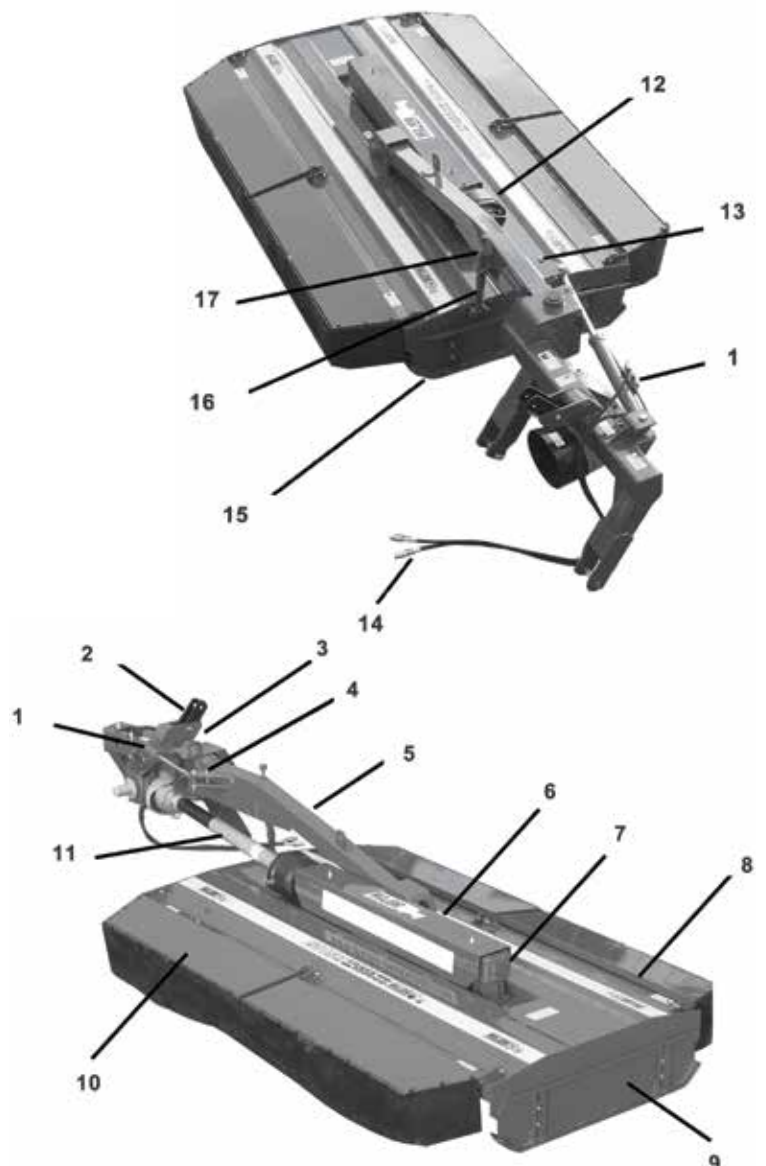

Blade Rotation

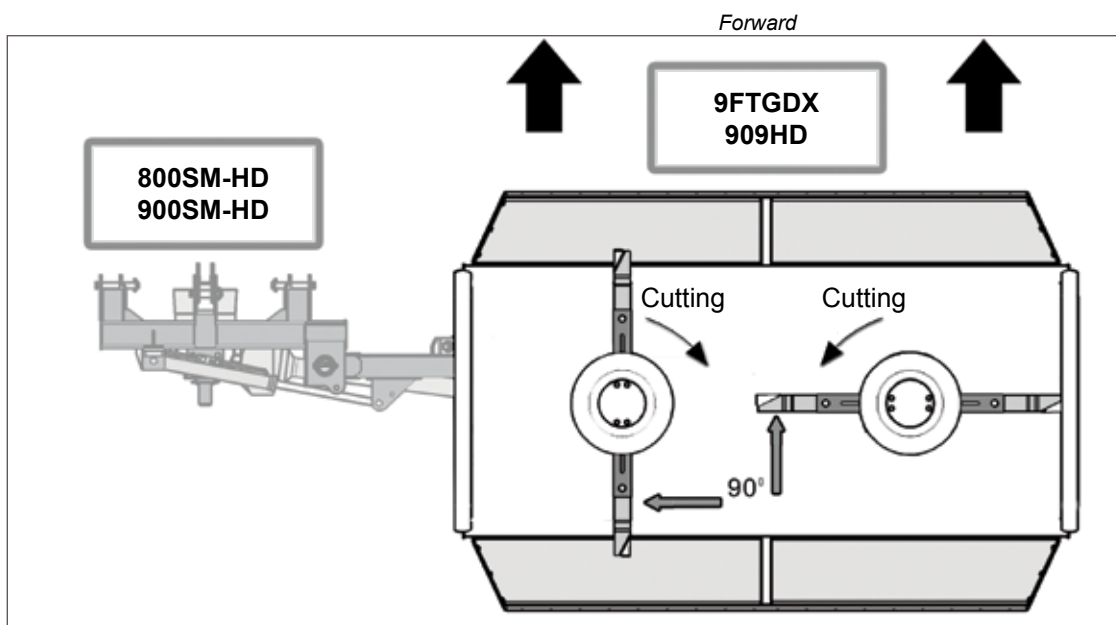

Blade system

Full breakdown of the blade assembly is provided in the Spare Parts section of this booklet

1 Blade mount	7 Blade pivot bolt
2 Gearbox output shaft	8 Blade pivot bush
3 Gearbox split pin	9 Blade
4 Blade back	10 Undersole disk
5 Blade back bolt	11 Overlap Blade
6 Blade back spacer	

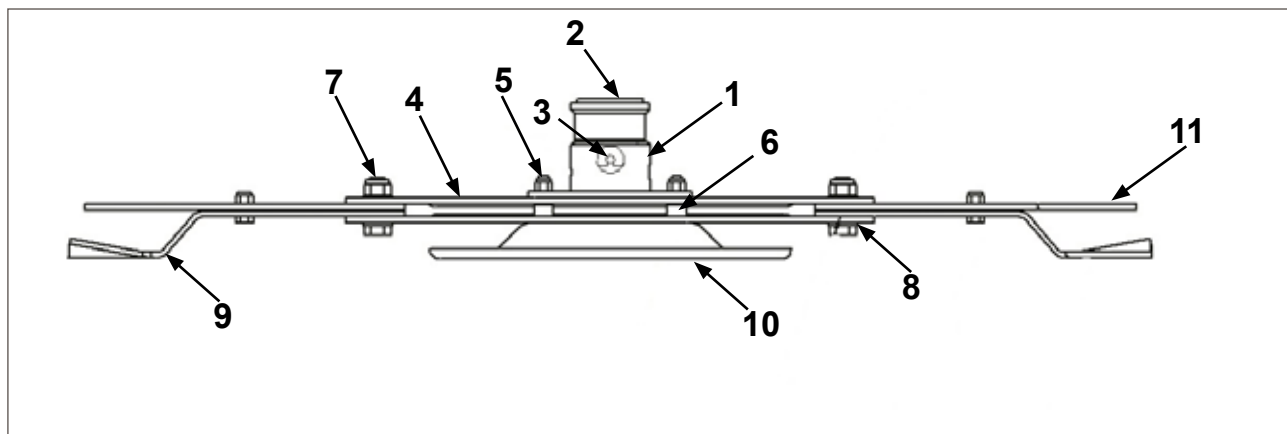

Drive-line gearboxes

Primary gearbox

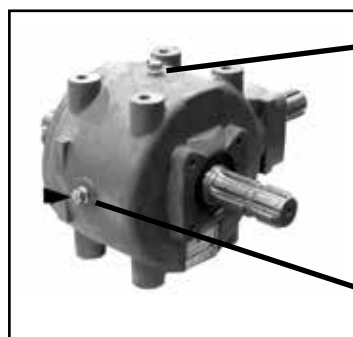

Oil filler
plug

Oil level
plug

Rotor gearbox

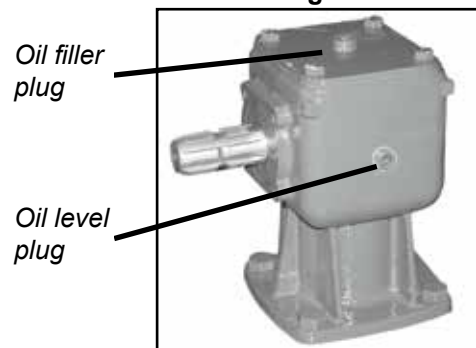

Oil filler
plug

Oil level
plug

Operating the Machine

Machine Set up

The Side Mount Topper is often supplied in kit form; please ensure that all components are fitted before using the machine. Ensure the damper system is correctly set up as shown below. Ensure primary PTO shaft is fitted correctly with the Shearbolt / Overrunning clutch fitted onto the primary gearbox of the machine and a standard yoke end on the tractor PTO drive.

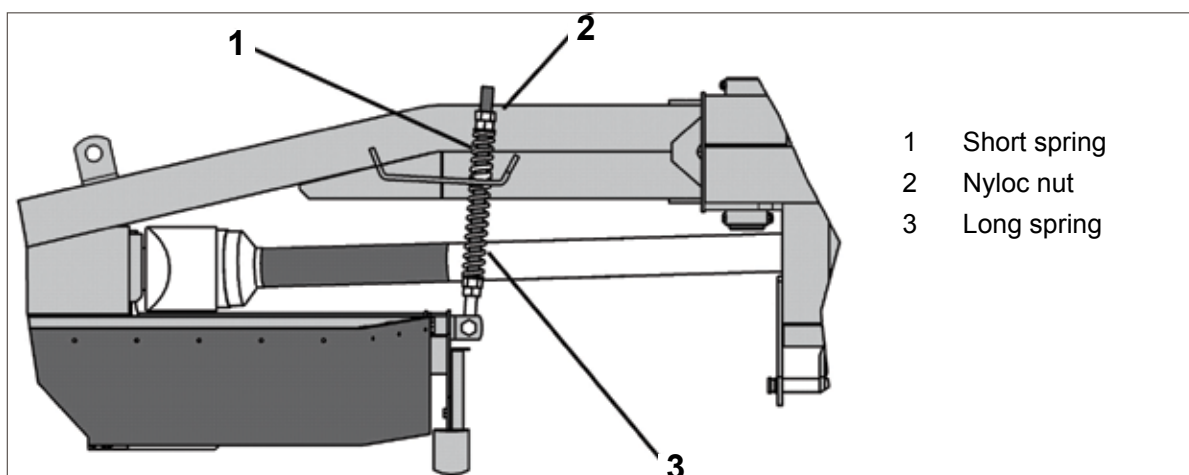

Hydraulic Ram Set Up Instructions (Side Mounted toppers)

1. Fit hydraulic quick fits to Tractor Spool
2. Fit Drain Line to pressure free return on tractor
3. Lift machine & power hydraulics to move body into mowing position.
4. Place spool in neutral position.
5. Tighten lower link stabilizer bars to ensure machine is tight on linkage & ensure that linkage bars are positioned to have machine slightly forward when in mowing position.
6. When mowing, the machine should be perpendicular or slightly forward to the direction of travel. If the machine is lagging behind the tractor then excessive pressure is being exerted on the valve & will cause the machine to creep back.

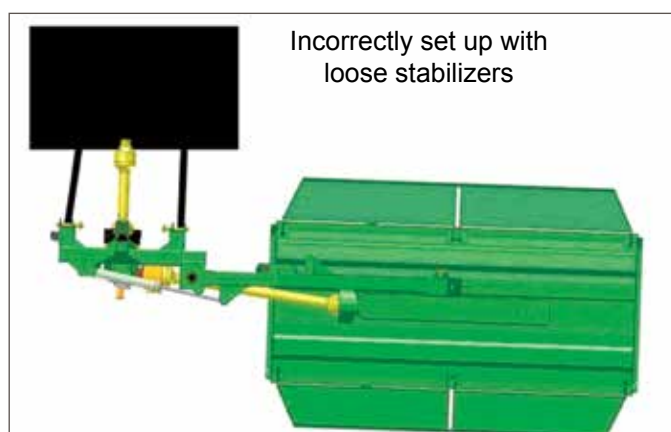
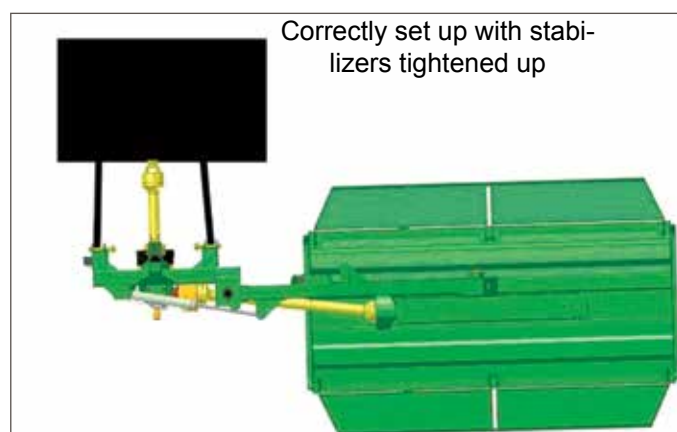
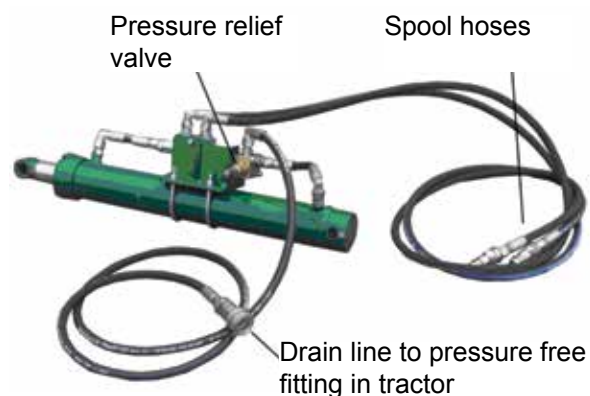

Mowing over rough ground can cause pressure on the relief valve with the consequence of the valve to operate. It is suggested to mow at lower speeds over these undulations

Attaching machine to the Tractor



ALWAYS OPERATE ON LEVEL GROUND WHEN HITCHING/UNHITCHING THE IMPLEMENT. THIS WILL PREVENT DANGEROUS MOVEMENT. NEVER ALLOW ANYONE TO STAND BETWEEN THE TRACTOR AND THE MACHINE.

Three Point Linkage Models

1. Adjust both lift arms of the tractor until they are level in relation to each other.
2. Hitch the lower linkage arms to the Machine and connect the top link and PTO shaft. Ensure that the locking pins are secure.
3. With the Machine lowered in its operating position, adjust the top link until the strap is slack, allowing the Machine to produce a uniform finish in varying ground conditions.
4. Check the PTO shaft for length as described previously. Connect the PTO shaft. Ensure PTO check chains are anchored to prevent PTO guarding from rotating.
5. Connect the hydraulic hoses to the appropriate connections (selected models only).

SIDE MOUNTED TOPPERS

1. Connect tractor to linkage
2. With linkage set parallel to the ground raise the topper such that the topper "heel" is approx. 25mm from the ground. Adjust the springs such that the "toe" is slightly higher at approx. 40mm from the ground.
3. Adjust the tractor linkage stay bars such that the topper runs parallel to the tractor.

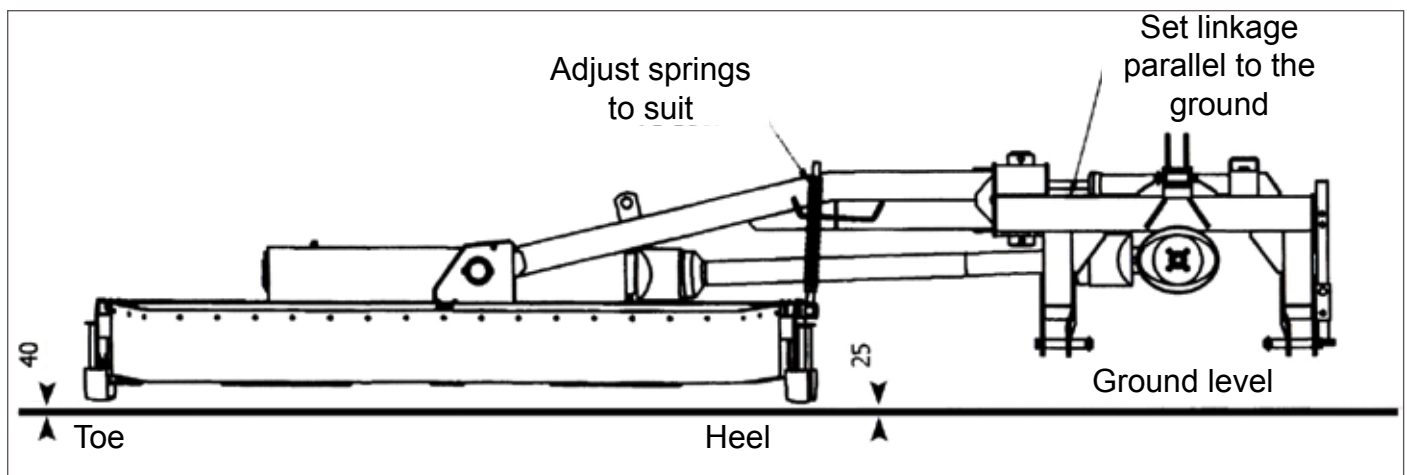
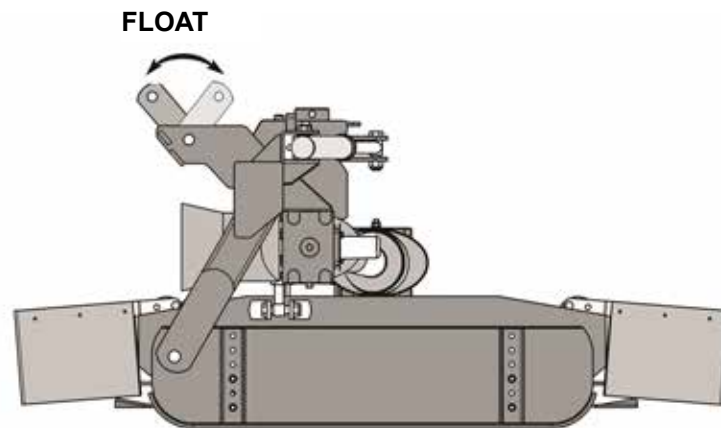

Transport Position



Before raising the machine wait until the transmission and the blades are completely still.
During the transport of the machine it is recommended that the PTO shaft is disconnected.

1. Check machine is hitched to the tractor as described. Ensure the tractor parking brake is applied
2. Ensure moving parts become still then transform the machine into transport position by hydraulic control
3. During the transport and any time the machine shall be raised, the raising device shall be adjusted to assure that the machine is at least 250mm over the ground.

Transport Position - Side Mounted Topper

1. Check machine is hitched to the tractor as described. Ensure the tractor parking brake is applied
2. Lift the body clear from the ground with the tractor 3 point linkage
3. Transform the machine into transport position by hydraulic control.
4. Lock in position with the transport locking pin.

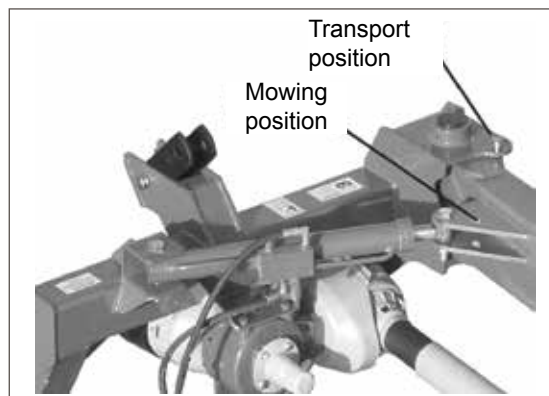

Adjusting the skids and cutting height

Adjust the skids by lifting the machine and removing the four skid retaining bolts & relocating the skid to the desired height.



NOTE: During the adjustment the skid may become detached and must be supported adequately.

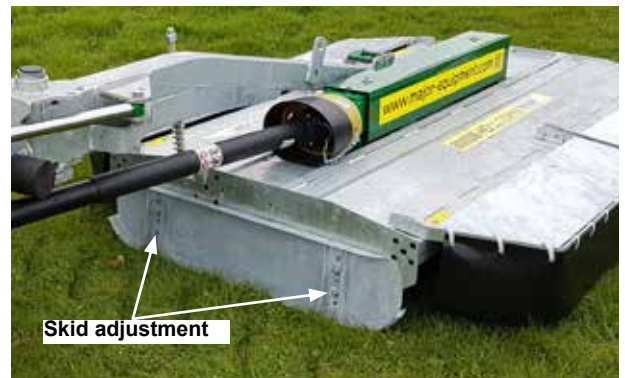

Wheel Assembly

The wheel assembly is not suitable for reversing. Place the pin in the appropriate location for either transport or mowing.

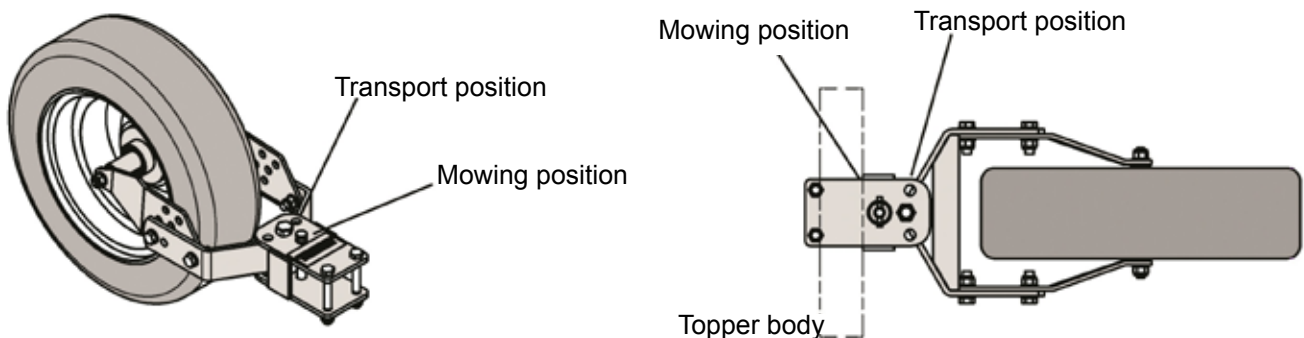

Hydraulic Breakaway Adjustment



The relief valve is set at the factory to 1800 PSI.
Ensure the Breakaway Return line is connected to the free flow return port on the tractor

The relief valve is located as shown on the hydraulic ram. To adjust the breakaway (if required):

1. Anchor the position of the Allen Screw using the Allen key
2. Slacken off the Collar Nut
3. Wind in the Allen Screw to increase the resistance (i.e. prevent the body from slipping back).
4. Lock the Allen Screw in the new position with the Collar Nut



Only adjust 1/4 of a turn at a time and test. Over adjustment will prevent the breakaway and may cause damage to the machine and/or the tractor. Adjustments must be carried out by a skilled and competent person.

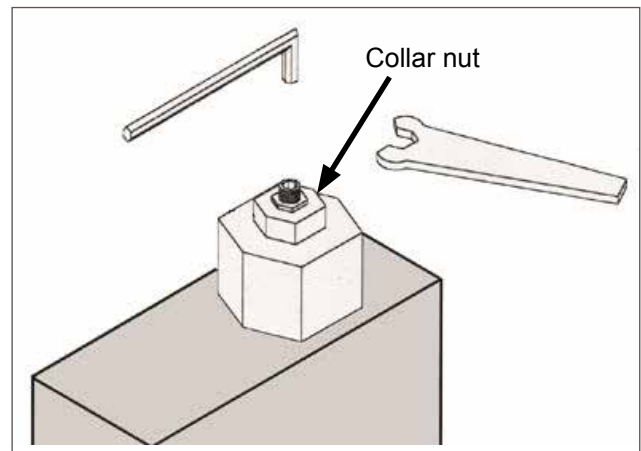

Operating the Machine/Mowing



Never place limbs under the machine while rotors are turning. Rotors can remain turning for up to 1 minute after disengaging PTO.



While operating this machine the PTO input rate should not exceed the RPM stated in the Product Specifications section of this booklet. Always operate on level ground when connecting/disconnecting the implement. This will prevent dangerous movement.



Never allow anyone to stand between the tractor and the machine. Ensure the machine is attached correctly to the tractor as previously described. Always start up the tractor PTO at a low RPM. Build up to operating speed, select a suitable forward gear & proceed to cut grass.

1. Hitch the machine as outlined in the previous section. Ensure bystanders are clear from the machine & cannot be hit with debris expelled from the machine.
2. Check PTO shaft is fully engaged on tractor PTO splines.
3. Raise the machine by hydraulic control.
4. Start up the tractor PTO at a low RPM.
5. Build up to operating speed, select a suitable forward gear & proceed to cut grass.

Maintenance

In order to keep your Major machine in a good working order it is necessary to conduct maintenance on a regular basis. Only competent and skilled persons who have fully read and understood this operator's manual are allowed to carry out maintenance on this machine. It is important to replace worn parts immediately with genuine Major spare parts. These parts are manufactured to the same specification as the machine and will provide the best result. Genuine Major spares can be obtained from MAJOR or your local MAJOR dealer.

All maintenance checks and operations must be carried on a firm level ground. The machine must always be disconnected from the tractor before any cleaning, lubricating and servicing operations can be carried out. If works must be carried out under the machine, ensure that the props, jacks, stands, hoists or cranes are capable of supporting the machine securely.

If emergency operations are required whilst the machine is connected to the tractor, switch off the engine of the tractor, remove the key from the ignition, engage the parking brake and disengage the PTO. An example of such emergency situation is the complete blockage of the machine in the field. To clear out the blockage follow the safety steps described above and clear out the blockage. Ensure there are no ropes, twines or wires wrapped around the rotors.

Machine storage

To prolong the life of your machine it is recommended to store it in a dry environment. Prior to parking the machine for storage, wash the machine thoroughly, especially underneath, and ensure that there is no grass or debris left on the machine. Lubricate all pivot points with EP2 type grease. Check for oil leaks and fix these if required. Any parts of the machine with damaged paint/galvanised surface must be painted.

PTO Shaft Maintenance

Guard Removal and Yoke End Greasing

1. Prise back locking tabs
2. Pull back PTO Guard
3. Grease points as shown
4. Push Guard into position
5. Click into place
6. Tie check chain

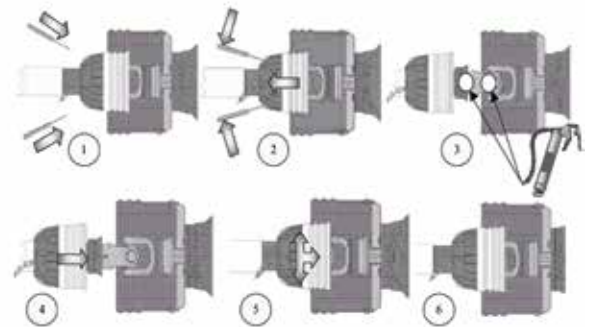

PTO Greasing Intervals

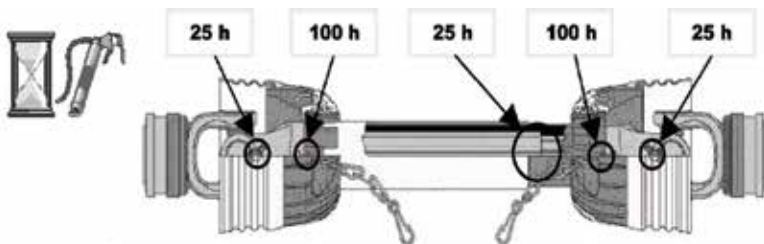

Shearbolt Replacement (if applicable)

1. Slide yoke shield back.
2. Drive out sheared bolt with hammer and punch.
3. Align holes and install new shear bolt. (Use only genuine replacement shear bolts)
4. Slide yoke shield securely in place



Always fit PTO shaft with the shearbolt/slip-clutch end connected to the machine as directed on the PTO guarding.

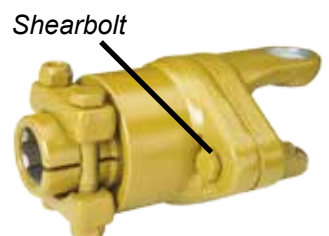

Transmission Bolts

All nuts and bolts in the transmission including Rubber couplings, Star Drives, PTO Shafts and Gearboxes should be checked for tightness after mowing at the following intervals:

1st 50 Acres

1st 100 Acres

1st 250 Acres

And every 250 acres thereafter.

Roller (if applicable)

Check the condition of the rollerend (stub axle) at the end of every season. Roller shaft (stub) must be able to rotate freely and without excessive play. If necessary, remove the roller assembly and adjust the tightness of the bearings.

Replacement of wear parts

Blades, blade backs, blade bushing, blade bolts and nuts must be checked on a regular basis for wear and deflection. MAJOR recommends to visually check the blade assemblies every 40 hours of operation. This interval may change depending on the operational conditions.

Replace any damaged or worn parts immediately, failure to do so can result in blade breakages and can cause damage to the equipment or injuries to the operator and others nearby.

Blunt blades must be sharpened or replaced, failure to do so will result in a poor quality cut and excessive use of power from your tractor.



If the machine is equipped with wheels, wheel nuts must be checked daily. Air pressure within pneumatic tyres must be maintained at 2 Bar. Solid wheels must be checked for wear and damage and if necessary replaced immediately.



ENSURE BLADE ROTATION AND TIMING IS CORRECT AFTER SERVICING TRANSMISSION.



Pay attention when servicing or detaching components from the machine. Subassemblies and parts e.g. blade assemblies, gearboxes, rollers, guards, skids, wheels etc. can weigh up to 100 kilograms individually and must be supported adequately before fully detaching from the machine.

Clearing out a blockage



Always wear appropriate PPE when clearing out blockages.

If blockage of blades occurs proceed as follows:

1. Set the machine into transport position (including the top links);
2. Park the tractor on level ground, switch off the engine and remove the key from the ignition;
3. Apply a handbrake and disconnect the PTO shaft;
4. Using a pressure washer clear out the excess material built up around the blades. If the pressure washer is not available use your hand to remove the grass from around the blades, bearing in mind that there might be wires wrapped up around the rotors.

Wing shafts alignment (if applicable)

Ensure that after servicing the transmission, the wing pto shaft yokes are correctly aligned as shown in the diagram below – winged models only. If the shaft journals are fitted incorrectly the damage will only occur when the wings are raised into transport position.

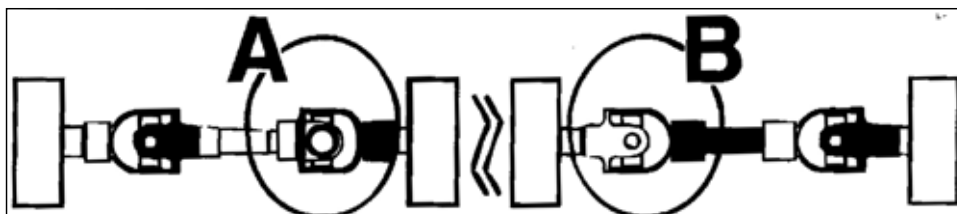

Troubleshooting

Fault	Cause	Remedy	
Machine is getting blocked	Material too high or too much material	Reduce the ground speed but maintain required rpm from the PTO input	
	Grass is too wet	Stop and wait until grass is dried	
	Worn or dull blades	Sharpen or replace blades	
Leaves a streak of uncut or partially cut grass	Blades dull or bent	Sharpen or replace blades	
	Carrier RPM too low	Use correct PTO speed	
	Field conditions are so wet that the tractor tyre is pushing grass into mud	Too wet to mow. Stop operation and wait until grass is drier	
	Ground speed too fast	Reduce ground speed by shifting to a lower gear	
	Possible build-up materials under mower	Clean mower	
	Blades mounted incorrectly (cutting edge against direction rotation)	Change blades so that cutting edge is facing correct rotation.	
Material discharges from mower unevenly; bunches of material along with swath	Material too high and/or too much material	Reduce ground speed but maintain the recommended RPM at tractor PTO or make two passes over material. Raise mower for the first pass and lower to desired height for the second and cut a 90 degree angle to first pass	
Gearbox overheating	Low on lubricant	Fill to proper level	
	Improper type lubricant	Replace with proper lubricant	
	Excessive grass / debris build-up around gearbox	Remove grass, etc from machine	
Blade/bullets is scalping ground	Mower too low	Raise mower-reset wheels	
	Field is ridged	Cut field at a different angle	
	Field is too wet	Stop and wait until it is dried	
Mower will not cut.	Shear bolt sheared	Install new shear bolt	
Blades/bullets wear too fast	Cutting in sandy conditions	Increase cutting height	
	Cutting in rocky conditions	Increase cutting height	
	Blades hitting ground	Increase cutting height	
Mower seems to require excessive power	Advancing into grass too rapidly	Reduce forward travel speed	
	Hitting ground	Raise mower and reset wheels	
	Worn or dull blades	Sharpen or replace blades	
	Tractor not large enough	Use larger horsepower tractor	
Excessive vibration	Check gearbox bolts	Tighten if loose	
	Check for loose nuts on blades	Tighten if loose	
	Blade broken	Replace blades, in set	
	New blade or bolts matched with worn blade or bolts	Replace blades or bolts in sets	
	Drivelines not phased correctly. Implement and tractor yokes must be in line	Phase the driveline. Replace if necessary	
Noisy machine	Worn bearing	Replace bearings	
	Low oil in gearbox	Check level and add oil	
	Loose Parts	Check all bolts are fully tightened	
	Wrong PTO rpm rate	Check PTO rate & adjust as necessary	
	Rotors bent / broken	Replace bent or missing blades	
	Bent PTO shaft		Check PTO shafts are aligned correctly
			Check output shaft on gearboxes are not bent
		Check driveline between gearboxes is aligned.	

Gearbox leaking	Damaged oil seal	Replace seal
	Bent shaft	Replace oil seal and shaft
	Shaft rough in oil seal area	Replace or repair shaft
	Oil seal installed incorrectly	Replace seal
	Oil seal not sealing in the housing	Replace seal or use a sealant on outside diameter of seal
	Oil level too high	Drain oil to proper level
	Hole in gearbox	Replace the gearbox
	Gasket damaged	Replace gasket
	Bolts loose	Tighten bolts

Lubrication schedule

Use EP2 type grease or equivalent.

Use oil which conforms to 85W/140 standards.

	Grease points	Initially	25 hours	40 hours	80 hours	400 hours
All PTO Shaft Yoke Ends		●	●			
PTO tubes		●			●	
Arm pivot	0/1				●	
Headstock pivot	0/1				●	
Hydraulic Ram	0/1			●		
Castor wheel pivot	0/2				●	
Castor wheel axle	0/2				●	
Check oil levels in the gearboxes					●	
Replace oil in gearboxes						●

Spare Parts

7FTGDH-HD (709HD)

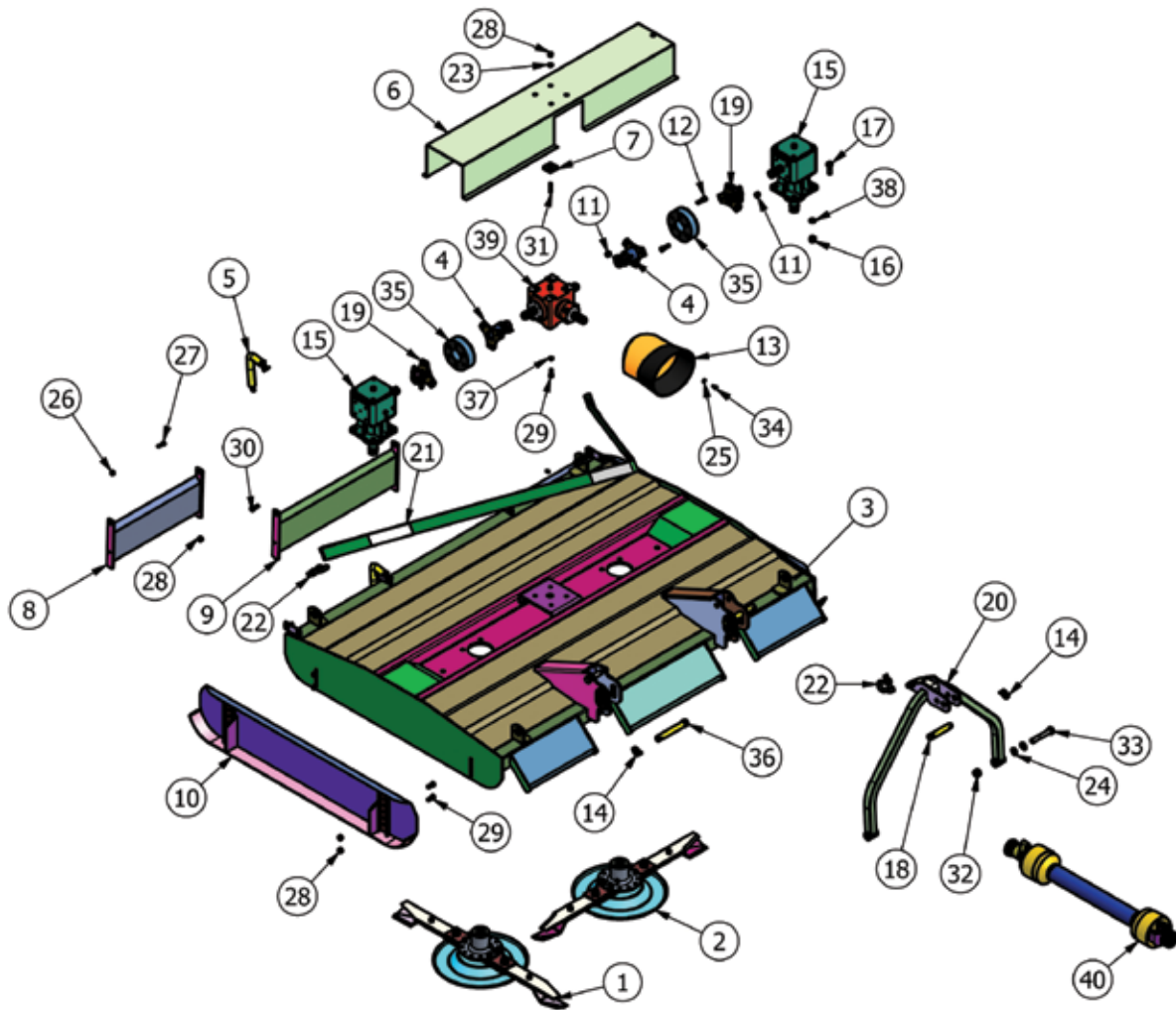

Item	Part No	Description	Qty
1	1125-D-BL	1125 BLADE (Anti_Clk)	1
2	1125-D-BR	1125 BLADE (Clk)	1
3	7GT-BD01	700M BODY FAB	1
4	7GTD	DRIVE TUBE (120mm)	2
5	909GT-GDC01	GUARD CHAIN ADJUSTER	2
6	9GT-COV	900M GEARBOX COVER	1
7	GM12-A	GUARD MOUNT BUFFER	4
8	SL45RG	405 REAR GUARD	2
9	SL65RG	REAR GUARD	1
10	SLH16AS	SKID (OFFSET)	2
11	1/2F	1/2" FINE NYLOC NUT	12
12	12x112FSKS	1/2"x1 1/2" FINE SOCKET HEAD 12.9	12
13	190.000.545	PTO GUARD (EXTENDED OVAL)	1
14	3546	LINCH PIN DIA 9.5	3
15	MJ40L	6 SPLINE "L" BOX RATIO 1.47	2
16	5/8F	5/8" FINE NYLOC NUT	8
17	58x2FBZP	5/8"x2" FINE BOLT	8
18	81	CAT 2 PIN DIA 25.4x110mm	1
19	8SM18	6 SPLINE STAR DRIVE	2
20	909-AF-01	909 A-FRAME 2011	1
21	9GTSTRP	900M STRAP (3226mm)	1

22	EW29A	5/8" "D" SHACKLE	3
23	FWM12	M12 FLAT WASHER	4
24	FWM20	M20 FLAT WASHER	4
25	FWM8	M8 FLAT WASHER	4
26	M10	M10 NYLOC NUT	2
27	M10x35SZP	M10x35 SET BOLT	2
28	M12	M12 NYLOC NUT	16
29	M12x30SZP	M12x30 SET BOLT	12
30	M12x35BZP	M12x35 BOLT	4
31	M12x50SB	M12x50mm STUD	4
32	M20	M20 NYLOC NUT	2
33	M20x120BZP	M20x120 BOLT	2
34	M8x16SZP	M8x16 SET BOLT	4
35	MJRC-113	113 PCD RUBBER COUPLING	2
36	112	CAT 2 PIN DIA 28.5x159mm	2
37	SW12	1/2" SPRING WASHER	4
38	SW58	5/8" SPRING WASHER	8
39	T27A	6 SPLINE "T" BOX RATIO 1.92 267245	1
40	T600810ENC12RB2	T60 SHEAR BOLT O/R	1

9FTGDX-HD

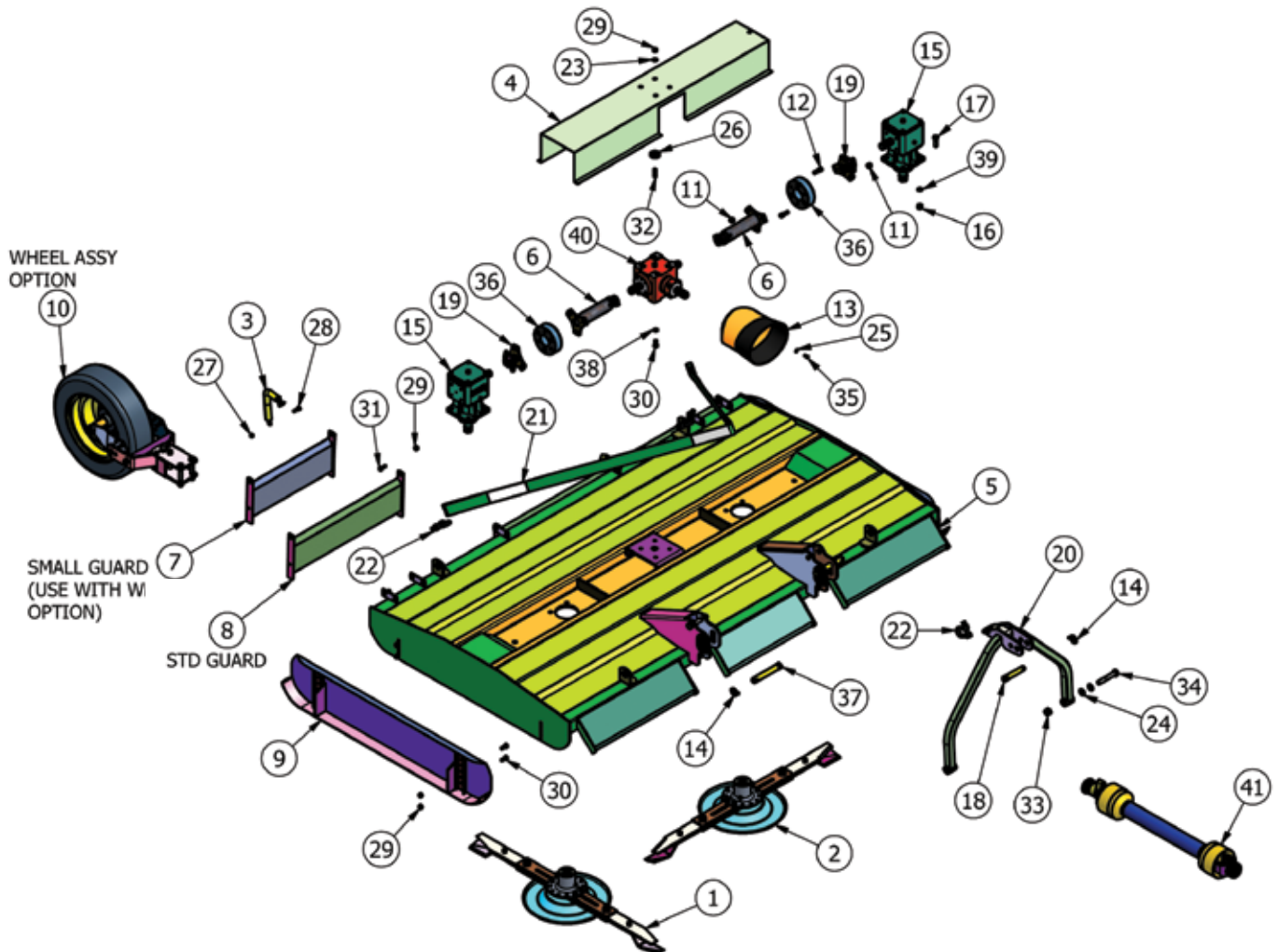

Item	Part No	Description	Qty
1	1385V3-D-BL	1385 BLADE (Anti_Clk)	1
2	1385V3-D-BR	1385 BLADE (Clk)	1
3	909GT-GDC01	GUARD CHAIN ADJUSTER	2
4	9GT-COV	900M GEARBOX COVER	1
5	9GTB-FAB	900M BODY FAB	1
6	9GTD	DRIVE TUBE (292mm)	2
7	SL45RG	405 REAR GUARD	2
8	SL65RG	REAR GUARD	3
9	SLH16AS	SKID (OFFSET)	2
10	TWA-002	TOPPER CAR WHEEL ASSY	2
11	1/2F	1/2" FINE NYLOC NUT	12
12	12x112FSKS	1/2"x1 1/2" FINE SOCKET HEAD 12.9	12
13	190.000.545	PTO GUARD (EXTENDED OVAL)	1
14	3546	LINCH PIN DIA 9.5	3
15	MJ40L	6 SPLINE "L" BOX RATIO 1.47	2
16	5/8F	5/8" FINE NYLOC NUT	8
17	58x2FBZP	5/8"x2" FINE BOLT	8
18	81	CAT 2 PIN DIA 25.4x110mm	1
19	8SM18	6 SPLINE STAR DRIVE	2
20	909-AF-01	909 A-FRAME 2011	1
21	9GTSTRP	900M STRAP (3226mm)	1
22	EW29A	5/8" "D" SHACKLE	3

23	FWM12	M12 FLAT WASHER	4
24	FWM20	M20 FLAT WASHER	4
25	FWM8	M8 FLAT WASHER	4
26	GM12-A	GUARD MOUNT BUFFER	4
27	M10	M10 NYLOC NUT	2
28	M10x35S2P	M10x35 SET BOLT	2
29	M12	M12 NYLOC NUT	16
30	M12x30S2P	M12x30 SET BOLT	12
31	M12x35B2P	M12x35 BOLT	4
32	M12x50SB	M12x50mm STUD	4
33	M20	M20 NYLOC NUT	2
34	M20x120B2P	M20x120 BOLT	2
35	M8x16S2P	M8x16 SET BOLT	4
36	MJRC-113	113 PCD RUBBER COUPLING	2
37	112	CAT 2 PIN DIA 28.5x159mm	2
38	SW12	1/2" SPRING WASHER	4
39	SW58	5/8" SPRING WASHER	8
40	T27A	6 SPLINE "T" BOX RATIO 1.92 267245	1
41	T600810ENC12RB2	T60 SHEAR BOLT O/R	1

909HD

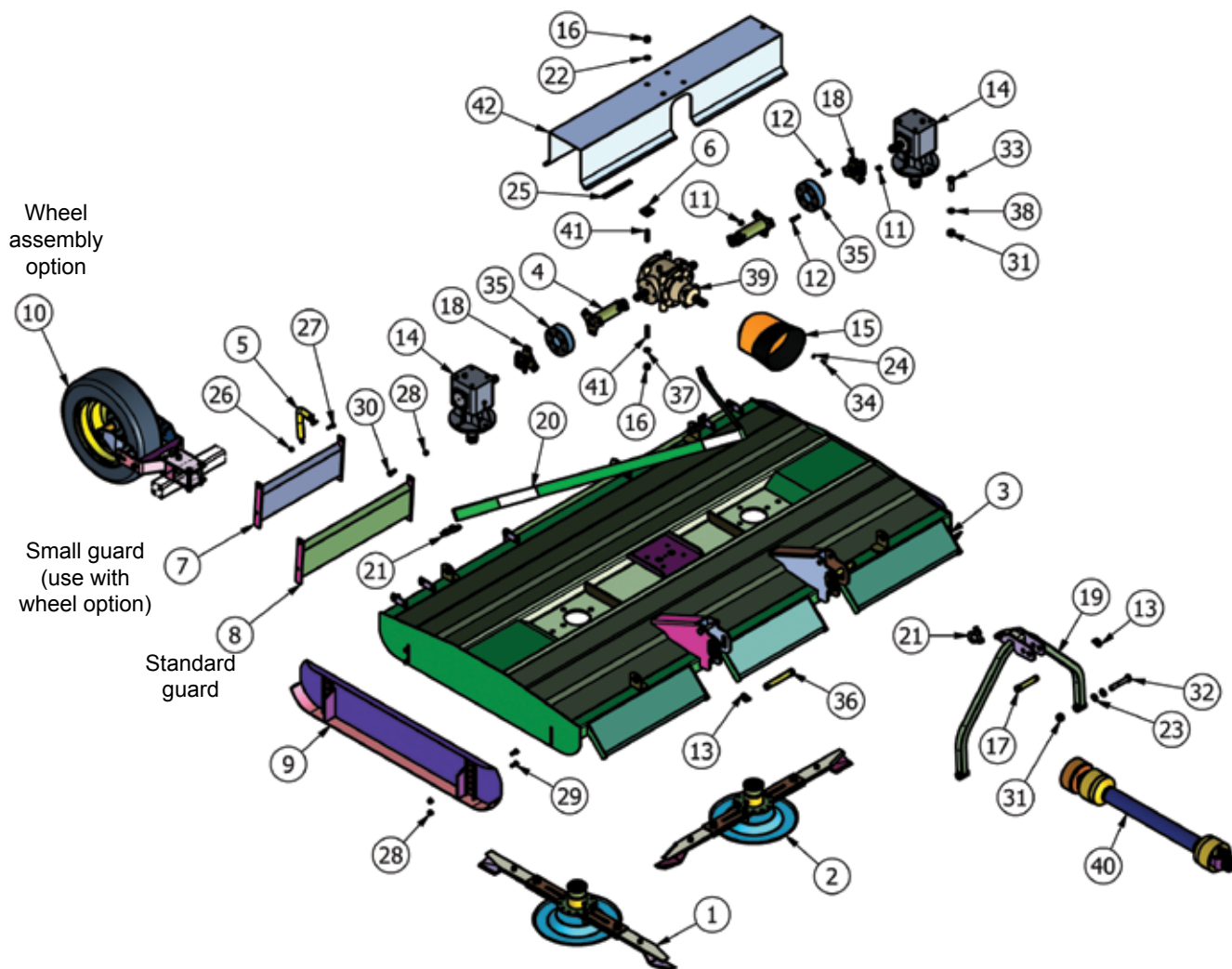

Item	Part No	Description	Qty
1	1385V2-D-BL	1385 BLADE (Anti_Clk)	1
2	1385V2-D-BR	1385 BLADE (Clk)	1
3	909GT-B01	909GT-BODY	1
4	909GT-DRV	DRIVE TUBE (242mm)	2
5	909GT-GDC01	GUARD CHAIN ADJUSTER	2
6	GM12-A	GUARD MOUNT BUFFER	4
7	SL45RG	405 REAR GUARD	2
8	SL65RG	REAR GUARD	3
9	SLH16AS	SKID (OFFSET)	2
10	TWA-002	TOPPER CAR WHEEL ASSY	2
11	1/2F	1/2" FINE NYLOC NUT	12
12	12x112FSKS	1/2"x1 1/2" FINE SOCKET HD 12.9	12
13	3546	LINCH PIN DIA 9.5	3
14	LF140T/1	6 SPLINE "L" BOX RATIO 1:1 140.881	2
15	190.000.545	PTO GUARD (EXTENDED OVAL)	1
16	5/8F	5/8" FINE NYLOC NUT	8
17	81	CAT 2 PIN DIA 25.4x110mm	1
18	8SM18	6 SPLINE STAR DRIVE	2
19	909-AF-01	909 A-FRAME 2011	1
20	9GTSTRP	900M STRAP (3226mm)	1
21	EW29A	5/8" "D" SHACKLE	3
22	FWM16	M16 FLAT WASHER	4

23	FWM20	M20 FLAT WASHER	4
24	FWM8	M8 FLAT WASHER	4
25	LS002	ANTI VIBRATION RUBBER	7
26	M10	M10 NYLOC NUT	2
27	M10x35SZP	M10x35 SET BOLT	2
28	M12	M12 NYLOC NUT	12
29	M12x30SZP	M12x30 SET BOLT	8
30	M12x35BZP	M12x35 BOLT	4
31	M20	M20 NYLOC NUT	10
32	M20x120BZP	M20x120 BOLT	2
33	M20x60BZP	M20x60 BOLT	8
34	M8x16SZP	M8x16 SET BOLT	4
35	MJRC-113	113 PCD RUBBER COUPLING	2
36	112	CAT 2 PIN DIA 28.5x159mm	2
37	SW58	5/8" SPRING WASHER	4
38	SWM20	M20 SPRING WASHER	8
39	T292B/2	6 SPLINE "T" BOX RATIO 1:1.47 292.005	1
40	V600910ENC12RW6	V60 FIXED SLIP CLUTCH	1
41	T292A-S1	T292 G/BOX STUD	8
42	909GT-COV	909 GEARBOX COVER	1

Wheel Option for 9FTGDX-HD and 909HD

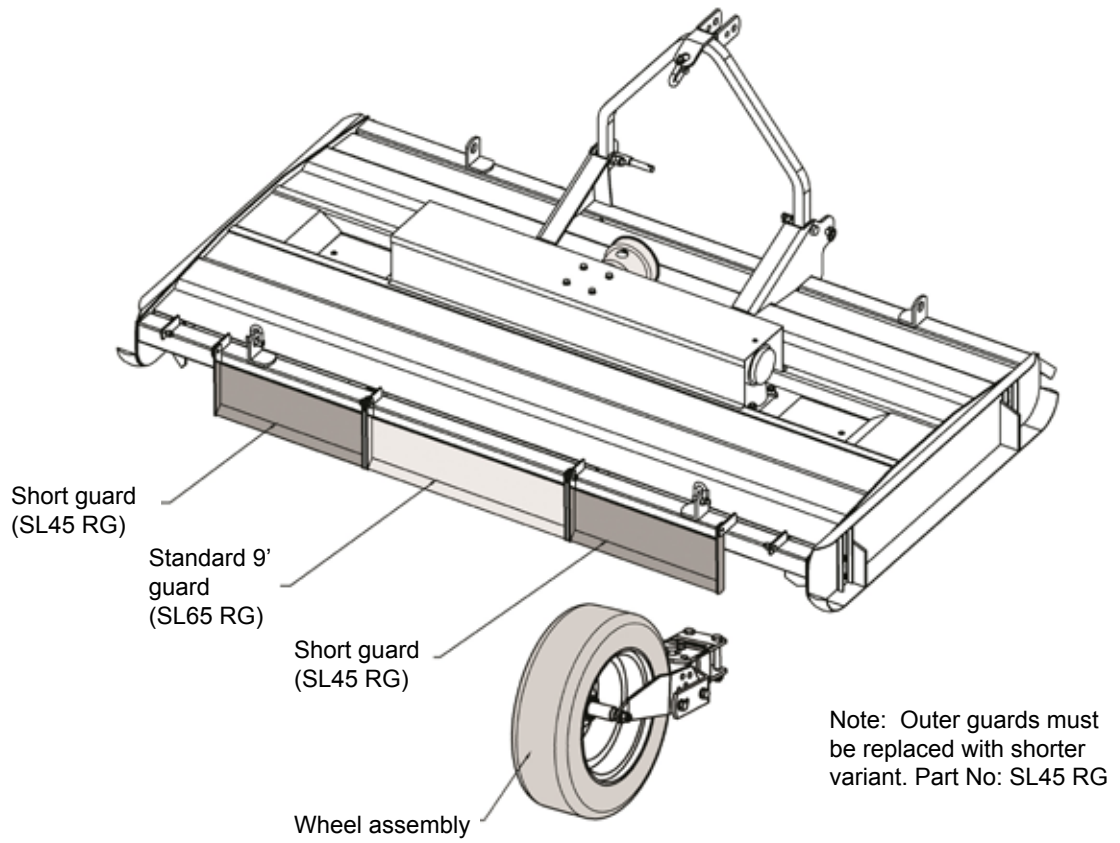

Wheel Assembly (TWA-002)

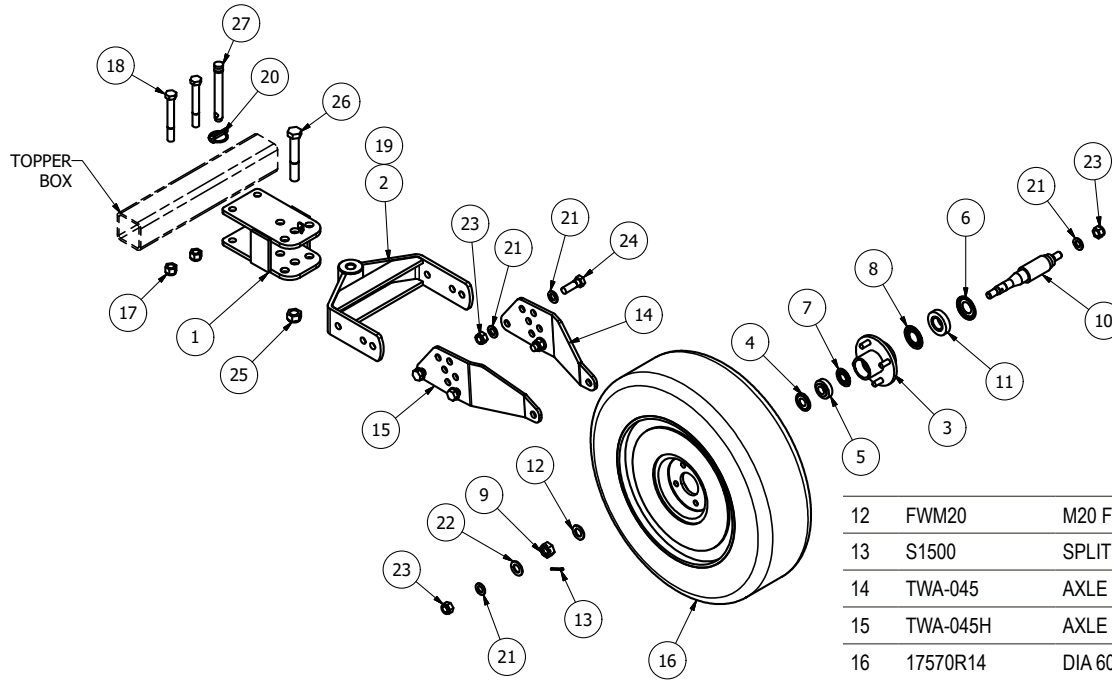

Item	Part No	Description	Qty
1	TWA-020	PIVOT MOUNT	1
2	TWA-030	PIVOT ARM	1
3	TWA-052	TOPPER 4 STUD AXLE HUB	1
4	30204-AV	NILOS RING 47x20	1
5	30204A	TAPER BRG 47x20x15.25	1
6	30206-AV	NILOS RING 62x30	1
7	915N30204	SHEILD 47x20	1
8	915N30206	SHEILD 62x30	1
9	M20FCASTLET	M20 FINE CASTLE NUT (THIN)	1
10	TWA-056	HUB SHAFT FOR 17570R14	1
11	30206	TAPER BRG 62x30x17.25	1

12	FWM20	M20 FLAT WASHER	1
13	S1500	SPLIT PIN 1/8"x1 1/2"	1
14	TWA-045	AXLE PLATE (CAR)	1
15	TWA-045H	AXLE PLATE (CAR)	1
16	17570R14	DIA 600x170mm	1
17	5/8F	5/8" FINE NYLOC NUT	2
18	58x5FBZP	5/8"x5" FINE BOLT	2
19	851	GREASE NIPPLE M8x1.25 STR	1
20	AN099/10	LINCH PIN DIA 9.5	1
21	FWM16	M16 FLAT WASHER	10
22	FWM20	M20 FLAT WASHER	1
23	M16	M16 NYLOC NUT	6
24	M16x50BZP	M16x50 BOLT	4
25	M20	M20 NYLOC NUT	1
26	M20x130BZP	M20x130 BOLT	1
27	S77	CAT 1 PIN DIA 19x127mm	1

Wheel Assembly (TWA-220)

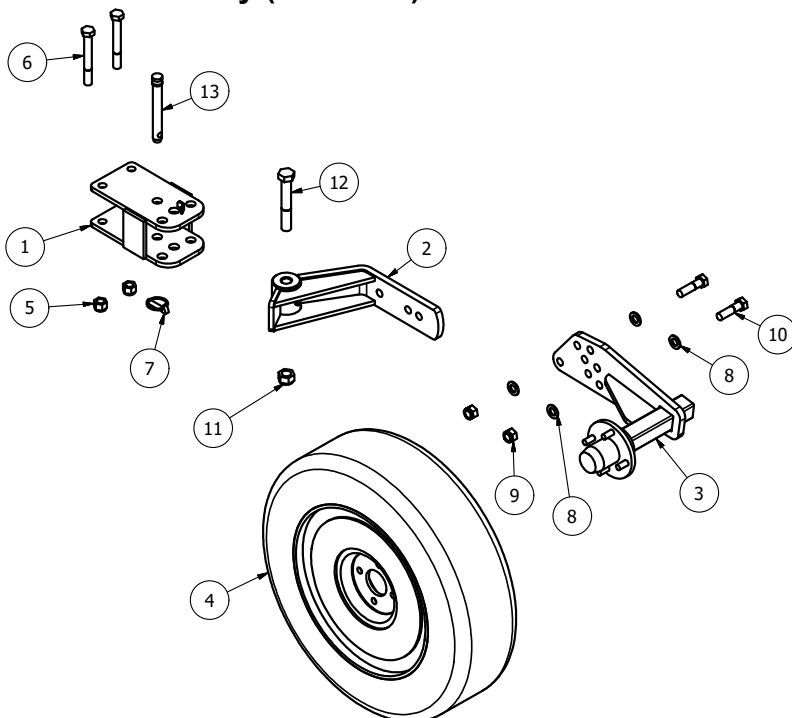

Item	Part No	Description	Qty
1	TWA-020	PIVOT MOUNT	1
2	TWA-210	PIVOT ARM	1
3	TWA-230	CASTOR WHEEL AXLE	1
4	17570R14	DIA 600x170mm	1
5	5/8F	5/8" FINE NYLOC NUT	2
6	58x5FBZP	5/8"x5" FINE BOLT	2
7	AN099/10	LINCH PIN DIA 9.5	1
8	FWM16	M16 FLAT WASHER	4
9	M16	M16 NYLOC NUT	2
10	M16x60BZP	M16x60 BOLT	2
11	M20	M20 NYLOC NUT	1
12	M20x130BZP	M20x130 BOLT	1
13	S77	CAT 1 PIN DIA 19x127mm	1

800SM-HD

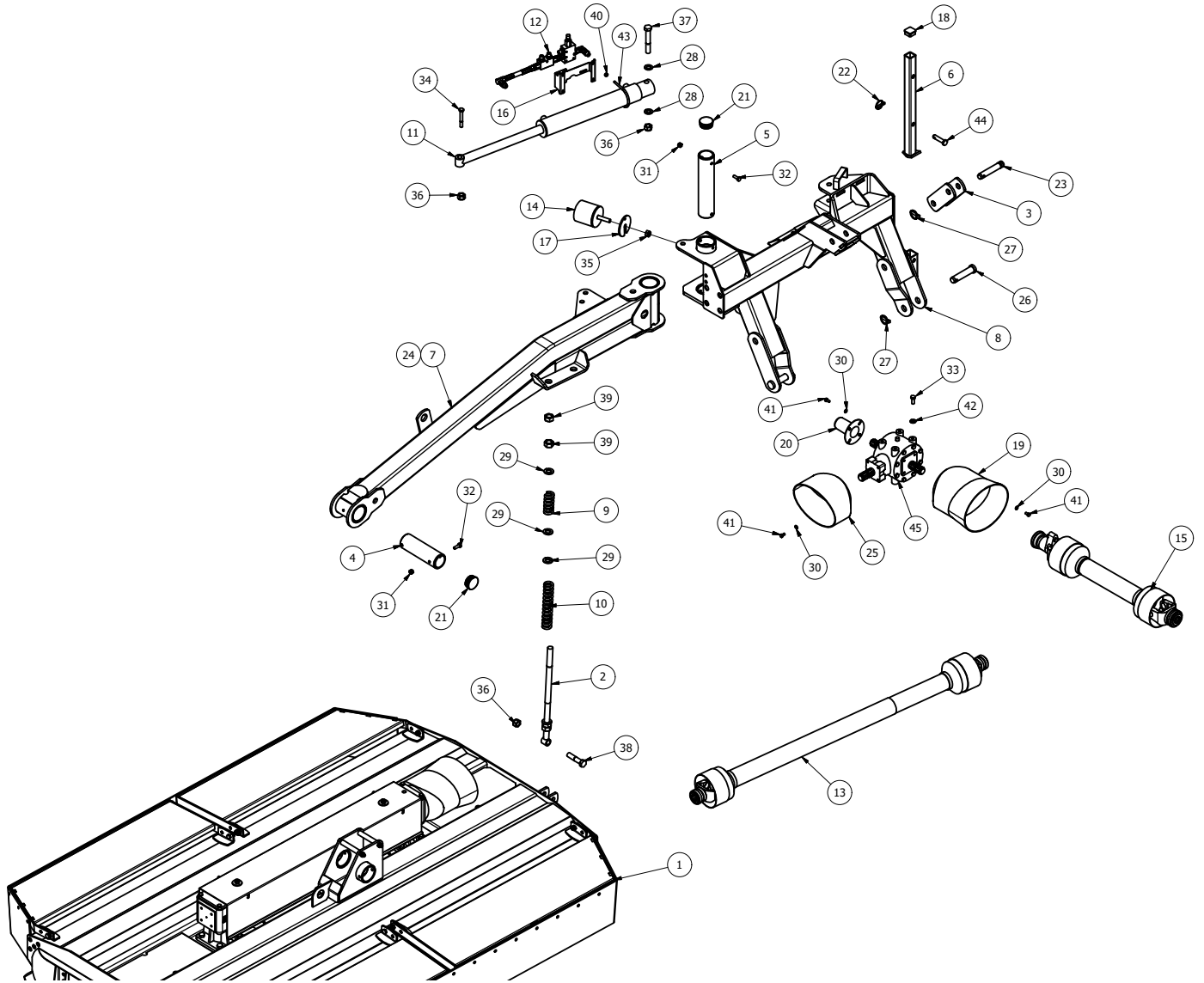

Item	Part No	Description	Qty
1	8SM-BGA	800SM GALV BODY ASSY	1
2	8SM5	DAMPER BAR	1
3	8SM8	TOP LINK FLOAT HINGE	1
4	9SM-PP04	BODY PIN TUBE	1
5	9SM-PP05	LINKAGE PIN TUBE	1
6	9SM-STD15	LINKAGE STAND	1
7	9SM-CA01GV	SM CARRY ARM (GALV)	1
8	9SM-L001GV	900SM LINKAGE (GALV)	1
9	8SM12-9	DAMPER SPRING (UPPER)	1
10	8SM13-9	DAMPER SPRING (LOWER)	1
11	900SM-09RAM	900SM RAM	1
12	9SM-HYD01	900SM HYDRAULICS	1
13	B5D116CES60002	COLLAR-COLLAR PTO	1
14	MOT10	DIA 100x100 BUFFER	1
15	T600610ENC12RB2	T60 SHEAR BOLT O/R	1
16	9SM-HYD06	VALVE MOUNT	1
17	8T19	BUFFER SPACER	1
18	111203	SQ 34-38mm INSERT (POL)	1
19	190.000.545	PTO GUARD (EXTENDED OVAL)	1
20	190592	PTO HAT	1
21	199268	DIA 63.5mm (2-4mm) INSERT	2
22	37	LINCH PIN DIA 6	1
23	81	CAT 2 PIN DIA 25.4x110mm	1
24	820	GREASE NIPPLE 1/8" STR	2
25	8SM11-2	PTO GUARD (OVAL)	1
26	9162	CAT 2 PIN DIA 28.5x113mm	2
27	AN099/10	LINCH PIN DIA 9.5	3
28	FWM20	M20 FLAT WASHER	2
29	FWM24	M24 FLAT WASHER	3
30	FWM8	M8 FLAT WASHER	10
31	M10	M10 NYLOC NUT	8
32	M10x30SZP	M10x30 SET BOLT	8
33	M12x30SZP	M12x30 SET BOLT	4
34	M12x90BZP	M12x90 BOLT	1
35	M16	M16 NYLOC NUT	1
36	M20	M20 NYLOC NUT	3
37	M20x130BZP	M20x130 BOLT	1
38	M20x90BZP	M20x90 BOLT	1
39	M24HEX	M24 PLAIN NUT	2
40	M8	M8 NYLOC NUT	4
41	M8x16SZP	M8x16 SET BOLT	10
42	NL12SP	M12 SP NORDLOCK	4
43	S13916	DIA 83mm SILENCER CLAMP	2
44	S15010	CAT 0 PIN DIA 16x54mm	1
45	T304A	6 SPLINE 'T' BOX 304.215 1:1.93	1

800SM-HD Body

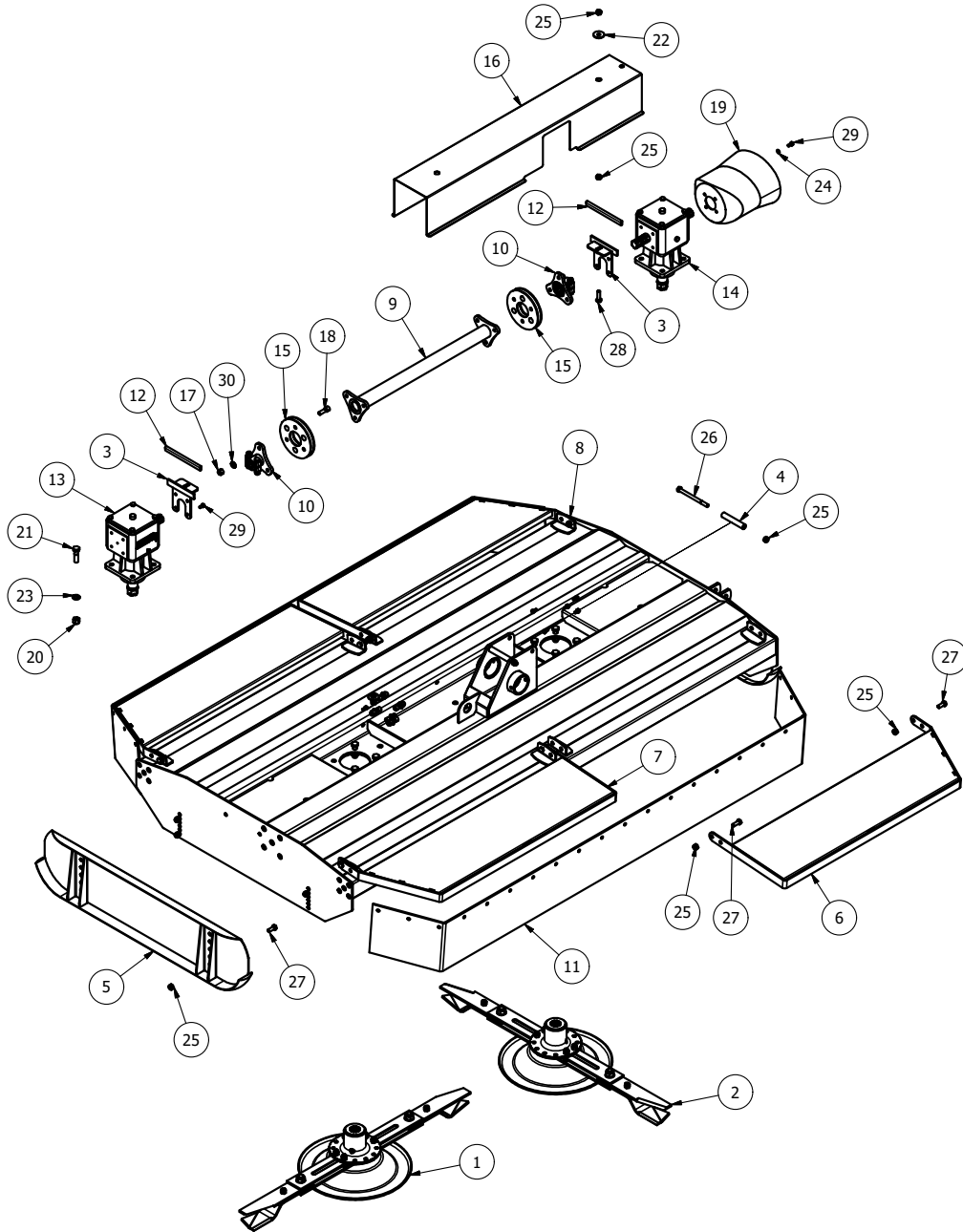

Item	Part No	Description	Qty
1	1239V2-D-BL	1239 BLADE (Anti_Clk)	1
2	1239V2-D-BR	1239 BLADE (Clk)	1
3	8SM-CVR	G/BOX COVER BRKT	2
4	8SM2-50GV	SPACER TUBE	2
5	NT11	SM SKID	2
6	8SM-GRD	800SM RIGHT HAND GUARD	2
7	8SM-GRDH	800SM LEFT HAND GUARD	2
8	8SM2-GLV	800SM BODY (GALV)	1
9	0940B077001	764mm DRIVE	1
10	60CSD	60mm STAR DRIVE	2
11	8SM-30	800SM SKIRT	2
12	LS002	ANTI VIBRATION RUBBER	2
13	MJ40L	6 SPLINE 'L' BOX RATIO 1.47 (347800)	1
14	MJ40T	6 SPLINE 'T' BOX RATIO 1.47 (347801)	1
15	MJRC-23	113 PCD COUPLING 4mm PLT	2
16	8SM19	800SM GEARBOX COVER	1
17	12HEX109	1/2F HEX 10.9	12
18	12x112FSKS	1/2"x1 1/2" FINE SOCKET HEAD 12.9	12
19	190.000.545	PTO GUARD (EXTENDED OVAL)	1
20	5/8F	5/8" FINE NYLOC NUT	8
21	58x214FBZP	5/8"x2 1/4" FINE BOLT	8
22	FWM12XL	M12 FLAT WASHER (EX-LARGE)	2
23	FWM16	M16 FLAT WASHER	8
24	FWM8	M8 FLAT WASHER	4
25	M12	M12 NYLOC NUT	22
26	M12x160BZP	M12x160 BOLT	2
27	M12x30SZP	M12x30 SET BOLT	16
28	M12x40SZP	M12x40 SET BOLT	2
29	M8x16SZP	M8x16 SET BOLT	8
30	NL12SP	M12 SP NORDLOCK	12

900SM-HD

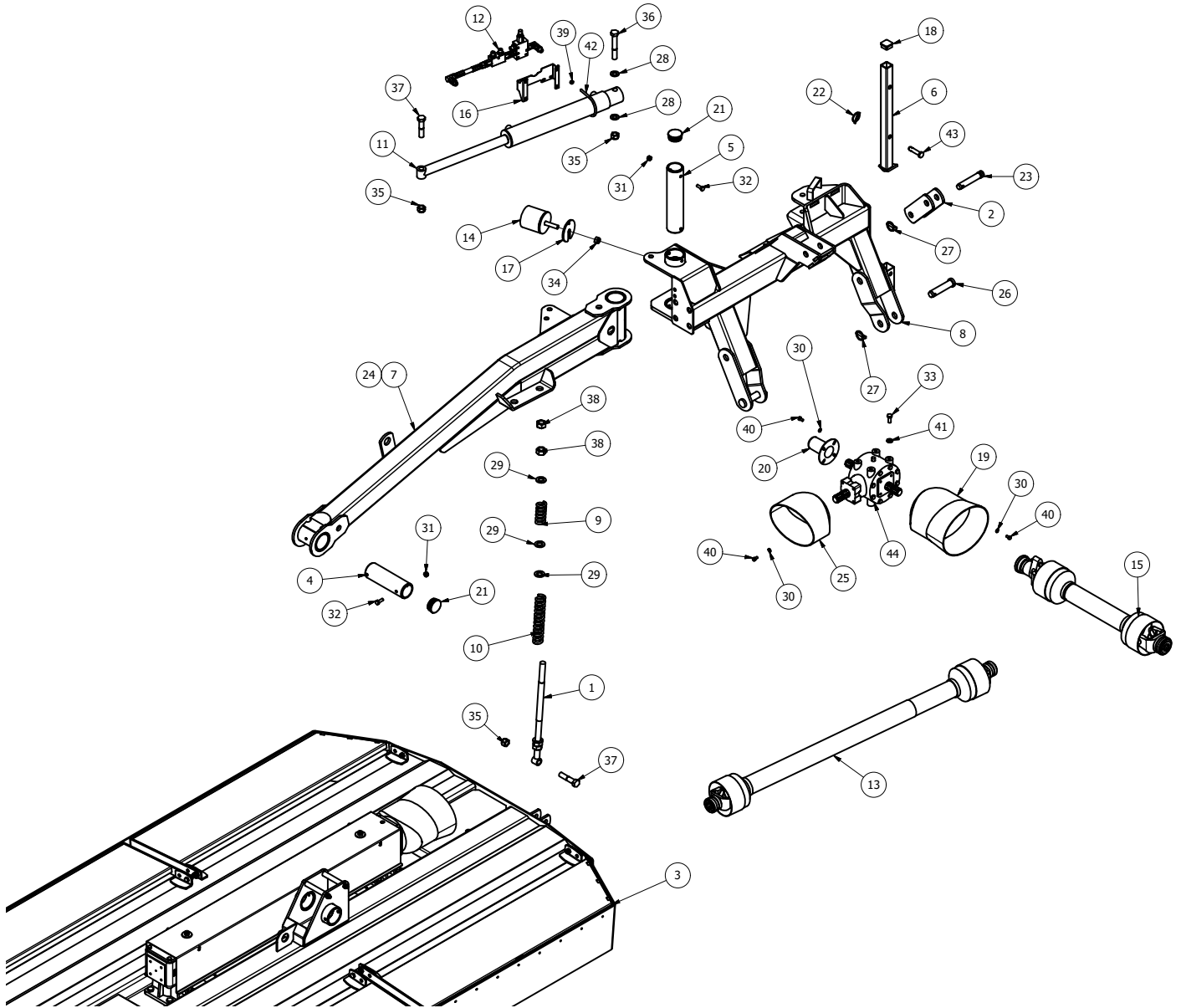

Item	Part No	Description	Qty
1	8SM5	DAMPER BAR	1
2	8SM8	TOP LINK FLOAT HINGE	1
3	9SM-BGA	900SM GALV BODY ASSY	1
4	9SM-PP04	BODY PIN TUBE	1
5	9SM-PP05	LINKAGE PIN TUBE	1
6	9SM-STD15	LINKAGE STAND	1
7	9SM-CA01GV	SM CARRY ARM (GALV)	1
8	9SM-L001GV	900SM LINKAGE (GALV)	1
9	8SM12-9	DAMPER SPRING (UPPER)	1
10	8SM13-9	DAMPER SPRING (LOWER)	1
11	900SM-09RAM	900SM RAM	1
12	9SM-HYD01	900SM HYDRAULICS	1
13	B5D116CES60002	COLLAR-COLLAR PTO	1
14	MOT10	DIA 100x100 BUFFER	1
15	T600610ENC12RB2	T60 SHEAR BOLT O/R	1
16	9SM-HYD06	VALVE MOUNT	1
17	8T19	BUFFER SPACER	1
18	111203	SQ 34-38mm INSERT (POL)	1
19	190.000.545	PTO GUARD (EXTENDED OVAL)	1
20	190592	PTO HAT	1
21	199268	DIA 63.5mm (2-4mm) INSERT	2
22	37	LINCH PIN DIA 6	1

23	81	CAT 2 PIN DIA 25.4x110mm	1
24	820	GREASE NIPPLE 1/8" STR	2
25	8SM11-2	PTO GUARD (OVAL)	1
26	9162	CAT 2 PIN DIA 28.5x113mm	2
27	AN099/10	LINCH PIN DIA 9.5	3
28	FWM20	M20 FLAT WASHER	2
29	FWM24	M24 FLAT WASHER	3
30	FWM8	M8 FLAT WASHER	10
31	M10	M10 NYLOC NUT	8
32	M10x30SZP	M10x30 SET BOLT	8
33	M12x30SZP	M12x30 SET BOLT	4
34	M16	M16 NYLOC NUT	1
35	M20	M20 NYLOC NUT	3
36	M20x130BZP	M20x130 BOLT	1
37	M20x90BZP	M20x90 BOLT	2
38	M24HEX	M24 PLAIN NUT	2
39	M8	M8 NYLOC NUT	4
40	M8x16SZP	M8x16 SET BOLT	10
41	NL12SP	M12 SP NORDLOCK	4
42	S13916	DIA 83mm SILENCER CLAMP	2
43	S15010	CAT 0 PIN DIA 16x54mm	1
44	T304A	6 SPLINE 'T' BOX RATIO 1:1.93 304.215	1

900SM-HD Body

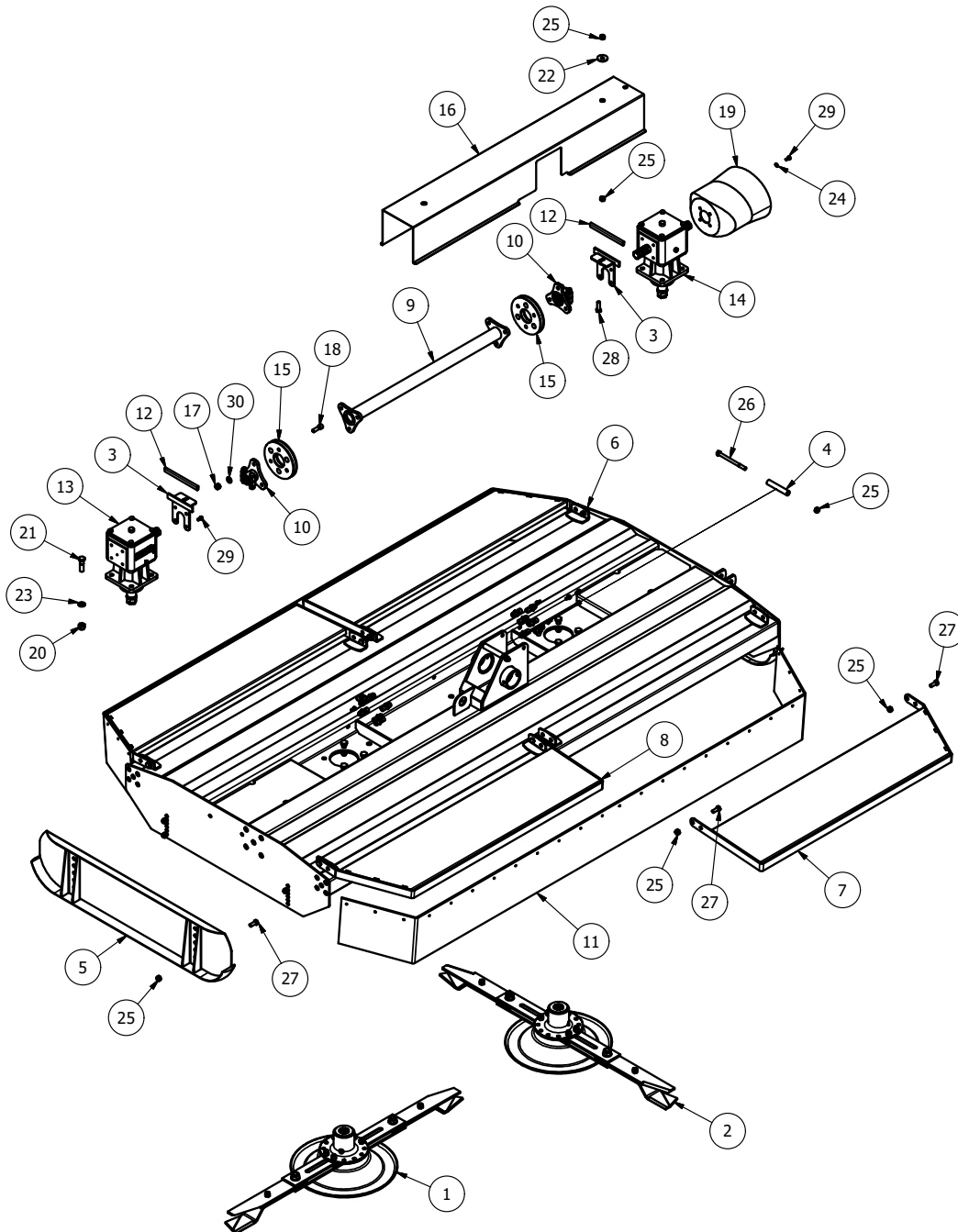

Item	Part No	Description	Qty
1	1385V3-D-BL	1385 BLADE (Anti_Clk)	1
2	1385V3-D-BR	1385 BLADE (Clk)	1
3	8SM-CVR	G/BOX COVER BRKT	2
4	8SM2-50GV	SPACER TUBE	2
5	NT11	SM SKID	2
6	9SM-B001GV	900SM BODY (GALV)	1
7	9SM-GRD1	900SM GUARD	2
8	9SM-GRD1H	900SM GUARD	2
9	0940B091001	912mm DRIVE	1
10	60CSD	60mm STAR DRIVE	2
11	9T-SKF	900T SKIRT	2
12	LS002	ANTI VIBRATION RUBBER	2
13	MJ40L	6 SPLINE 'L' BOX RATIO 1.47 (347800)	1
14	MJ40T	6 SPLINE 'T' BOX RATIO 1.47 (347801)	1

15	MJRC-23	113 PCD COUPLING 4mm PLT	2
16	9SM-G002	900SM GEARBOX COVER	1
17	12HEX109	1/2F HEX 10.9	12
18	12x112FSKS	1/2"x1 1/2" FINE SOCKET HEAD 12.9	12
19	190.000.545	PTO GUARD (EXTENDED OVAL)	1
20	5/8F	5/8" FINE NYLOC NUT	8
21	58x214FBZP	5/8"x2 1/4" FINE BOLT	8
22	FWM12XL	M12 FLAT WASHER (EX-LARGE)	2
23	FWM16	M16 FLAT WASHER	8
24	FWM8	M8 FLAT WASHER	4
25	M12	M12 NYLOC NUT	22
26	M12x160BZP	M12x160 BOLT	2
27	M12x30SZP	M12x30 SET BOLT	16
28	M12x40SZP	M12x40 SET BOLT	2
29	M8x16SZP	M8x16 SET BOLT	8
30	NL12SP	M12 SP NORDLOCK	12

800SM-HD and 900SM-HD Hydraulics

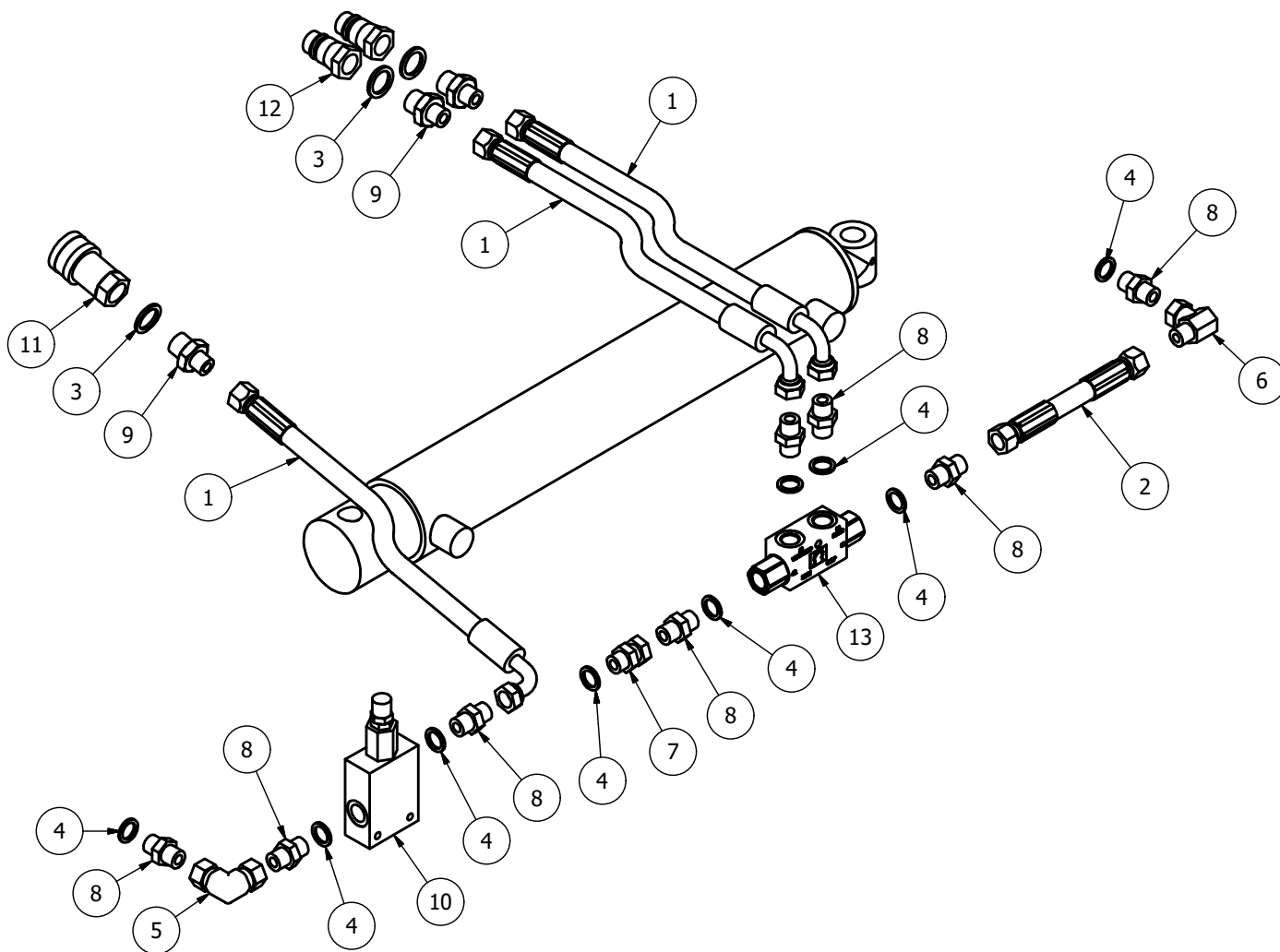

Item	Part No	Description	Qty
1	900SM-HOSE-A	3/8"x2000mm Str to Block 90	3
2	900SM-HOSE-B	3/8" Str to Str	1
3	EDOW12	1/2" DOWTY WASHER	3
4	EDOW38	3/8" DOWTY WASHER	9
5	EFF90-38	3/8" Female 90	1
6	EFM9038	3/8" F/M ELBOW	1
7	EMF38	3/8" M/F CONNECTOR	1
8	EMM38	3/8" M/M CONNECTOR	8
9	EMM3812	1/2-3/8" M/M CONNECTOR	3
10	LU00207000	PRESSURE RELIEF VALVE	1
11	QRF12	1/2" QUICK RELEASE FEMALE	1
12	QRM12	1/2" QUICK RELEASE MALE	2
13	VRDE-15-FF-38	DOUBLE PILOT CHECK VALVE	1

800SM-HD Blades

Blade System: 1239-D-BL and 1239-D-BR

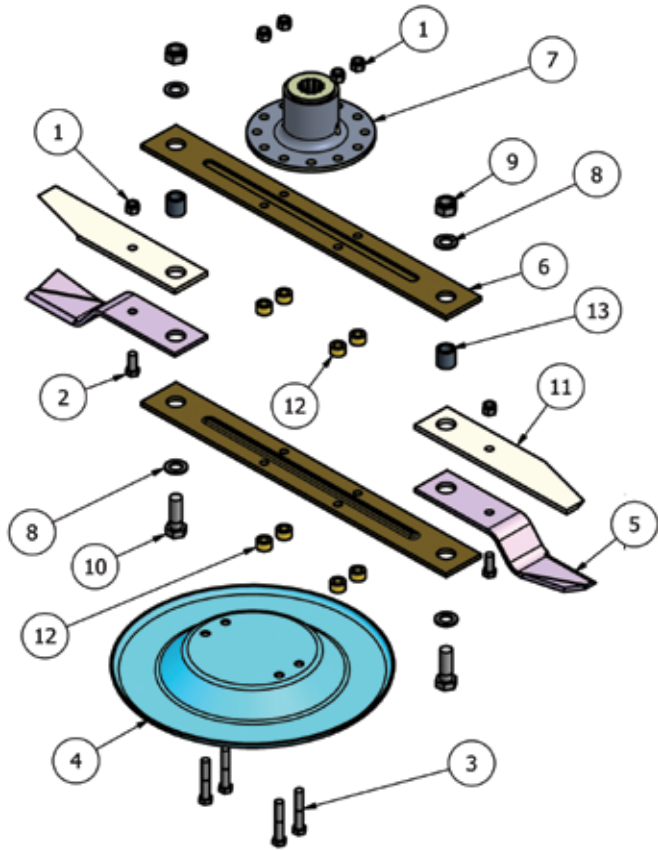

900SM-HD, 9FTGDX-HD Blades

Blade System: 1385V3-D-BL and 1385V3-D-BR

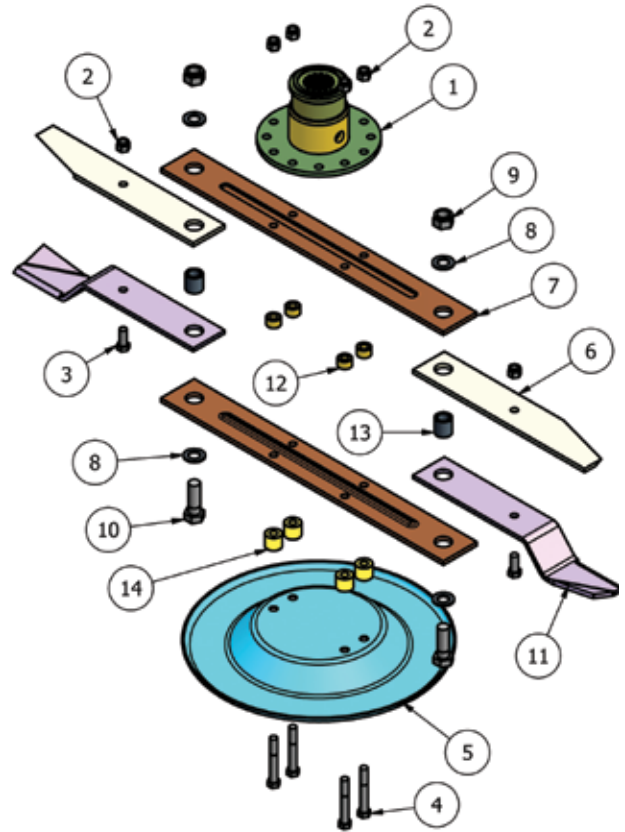

Item	Part No	Description	Qty
1	1/2F	1/2" FINE NYLOC NUT	6
2	12x114FBZP	1/2"x1 1/4" FINE BOLT	2
3	12x3FBZP	1/2"x3" FINE BOLT	4
4	9GT-USS	UNDER SOLE SKID	1
5	9GTB/A	SWING BLADE (Anti-Cik)	2
5	9GTB/C	SWING BLADE (Cik)	2
6	BLDB-623	BLADE BACK (623 CTR)	2
7	DF-BMP	J205 G/BOX BLADE MOUNT	1
8	FWM20	M20 FLAT WASHER	4
9	M20	M20 NYLOC NUT	2
10	M20x60BZP	M20x60 BOLT	2
11	NTSB12C	OVERLAP BLADE	2
12	12T-BBS	BLADE BACK SPACER	8
13	12T-LBB	OVERLAP BLADE BUSH	2

MACHINE	QTY
800SM-HD	1 clockwise 1 anti clockwise

Item	Part No	Description	Qty
1	DF-BMP	J205 G/BOX BLADE MOUNT	1
2	1/2F	1/2" FINE NYLOC NUT	6
3	12x114FBZP	1/2"x1 1/4" FINE BOLT	2
4	12x312FBZP	1/2"x3 1/2" FINE BOLT	4
5	9GT-USS	UNDER SOLE SKID	1
6	BLD-OV375	OVERLAP BLADE 375mm	2
7	BLDB-595	BLADE BACK (595 CTR)	2
8	FWM20	M20 FLAT WASHER	4
9	M20	M20 NYLOC NUT	2
10	M20x60BZP	M20x60 BOLT	2
11	NTSB10A1	601 SLASHER BLADE (Anti-Cik)	2
11	NTSB10A2	601 SLASHER BLADE (Cik)	2
12	12T-BBS	BLADE BACK SPACER	4
13	12T-LBB	OVERLAP BLADE BUSH	2
14	84RM-BAM	BLADE BACK SPACER-PLATED	4

MACHINE	QTY
900SM-HD	1 clockwise 1 anti clockwise
9FTGDX-HD	1 clockwise 1 anti clockwise

7FTGDX-HD Blades

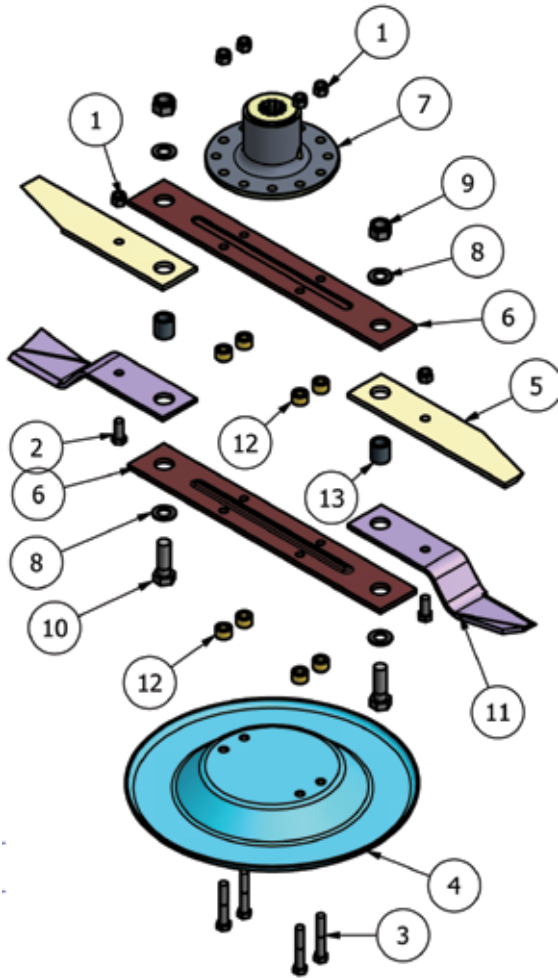

1097-D-BL Blades

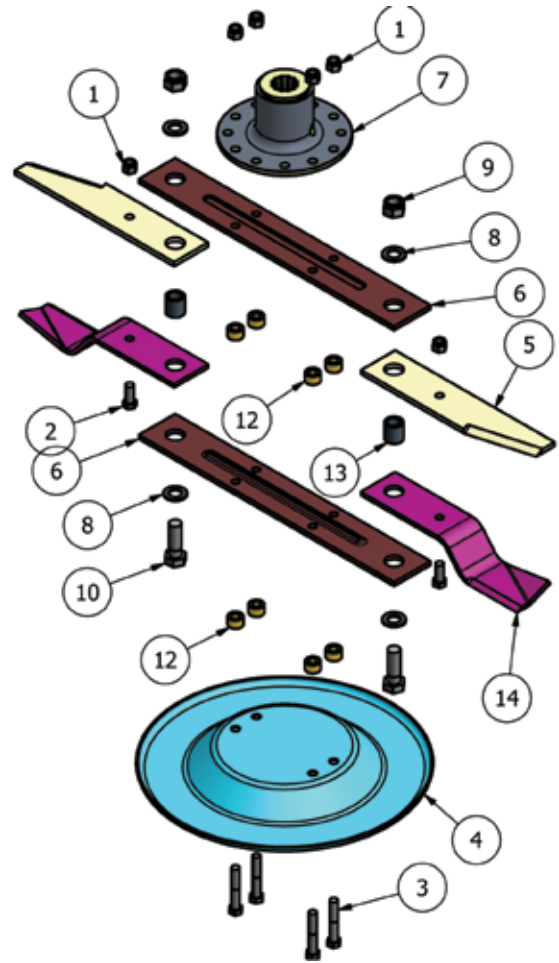

1097-D-BR Blades

Item	Part No	Description	Qty
1	1/2F	1/2" FINE NYLOC NUT	6
2	12x114FBZP	1/2"x1 1/4" FINE BOLT	2
3	12x3FBZP	1/2"x3" FINE BOLT	4
4	9GT-USS	UNDER SOLE SKID	1
5	NTSB12C	OVERLAP BLADE	2
6	GM26	BLADE BACK (481 CTR)	2
7	DF-BMP	J205 G/BOX BLADE MOUNT	1
8	FWM20	M20 FLAT WASHER	4
9	M20	M20 NYLOC NUT	2
10	M20x60BZP	M20x60 BOLT	2
11	9GTB/A	SWING BLADE (Anti-Clk)	2
12	12T-BBS	BLADE BACK SPACER	8
13	12T-LBB	OVERLAP BLADE BUSH	2

Item	Part No	Description	Qty
1	1/2F	1/2" FINE NYLOC NUT	6
2	12x114FBZP	1/2"x1 1/4" FINE BOLT	2
3	12x3FBZP	1/2"x3" FINE BOLT	4
4	9GT-USS	UNDER SOLE SKID	1
5	NTSB12C	OVERLAP BLADE	2
6	GM26	BLADE BACK (481 CTR)	2
7	DF-BMP	J205 G/BOX BLADE MOUNT	1
8	FWM20	M20 FLAT WASHER	4
9	M20	M20 NYLOC NUT	2
10	M20x60BZP	M20x60 BOLT	2
12	12T-BBS	BLADE BACK SPACER	8
13	12T-LBB	OVERLAP BLADE BUSH	2
14	9GTB/C	SWING BLADE (Clk)	2

MACHINE	QTY
7FTGDX-HD	1 clockwise 1 anti clockwise

909HD Blades

Blade System: 1385V3-D-BL and 1385V3-D-BR

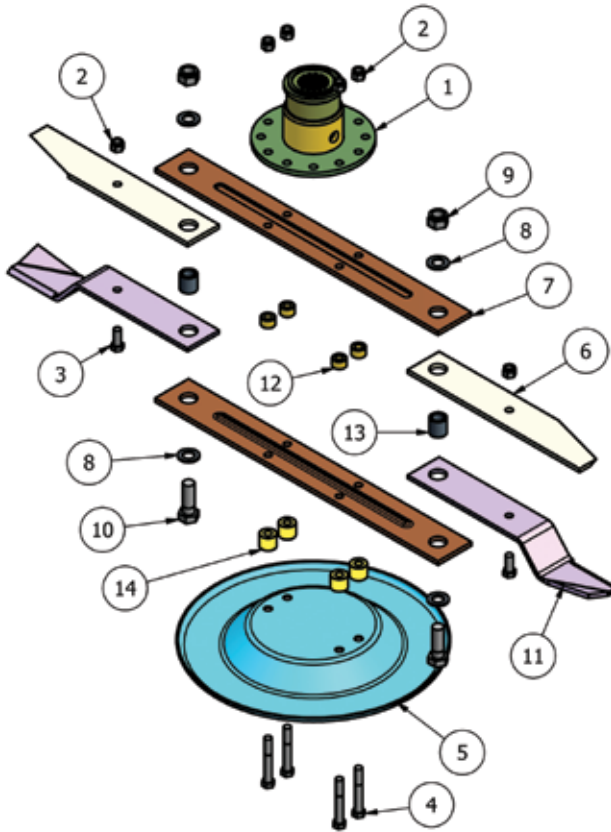

Item	Part No	Description	Qty
1	909GT-BM01	909GT BLADE MOUNT	1
2	1/2F	1/2" FINE NYLOC NUT	6
3	12x114FBZP	1/2"x1 1/4" FINE BOLT	2
4	12x312FBZP	1/2"x3 1/2" FINE BOLT	4
5	9GT-USS	UNDER SOLE SKID	1
6	BLD-OV375	OVERLAP BLADE 375mm	2
7	BLDB-595	BLADE BACK (595 CTR)	2
8	FWM20	M20 FLAT WASHER	4
9	M20	M20 NYLOC NUT	2
10	M20x60BZP	M20x60 BOLT	2
11	NTSB10A1	601 SLASHER BLADE (Anti-Clk)	2
11	NTSB10A2	601 SLASHER BLADE (Clk)	2
12	12T-BBS	BLADE BACK SPACER	4
13	12T-LBB	OVERLAP BLADE BUSH	2
14	84RM-BAM	BLADE BACK SPACER-PLATED	4

MACHINE	QTY
909HD	1 clockwise 1 anti clockwise

PTO Shafts

Machine	Primary	Secondary
800SM-HD	T600610ENC12RB2 (T60BOOR-900)	T501160ENC12C12
	T60 SHAFT OVERRUN+SHEARBOLT	T50 SHAFT COLLAR
900SM-HD	T600610ENC12RB2 (T60BOOR-900)	T501160ENC12C12
	T60 SHAFT OVERRUN+SHEARBOLT	T50 SHAFT COLLAR
9FTGDX-HD	T600810ENC12RW6	
	T60 SHAFT SLIP CLUTCH	
9FTGDX-HD (front mounted)	T601210ENC12RW6L	
	T60 SHAFT OVERRUN+CLUTCH FRONT	
909HD	V600910ENC12RW6	
	V60 SHAFT SLIP CLUTCH	

MJ40L-347.800-1.47

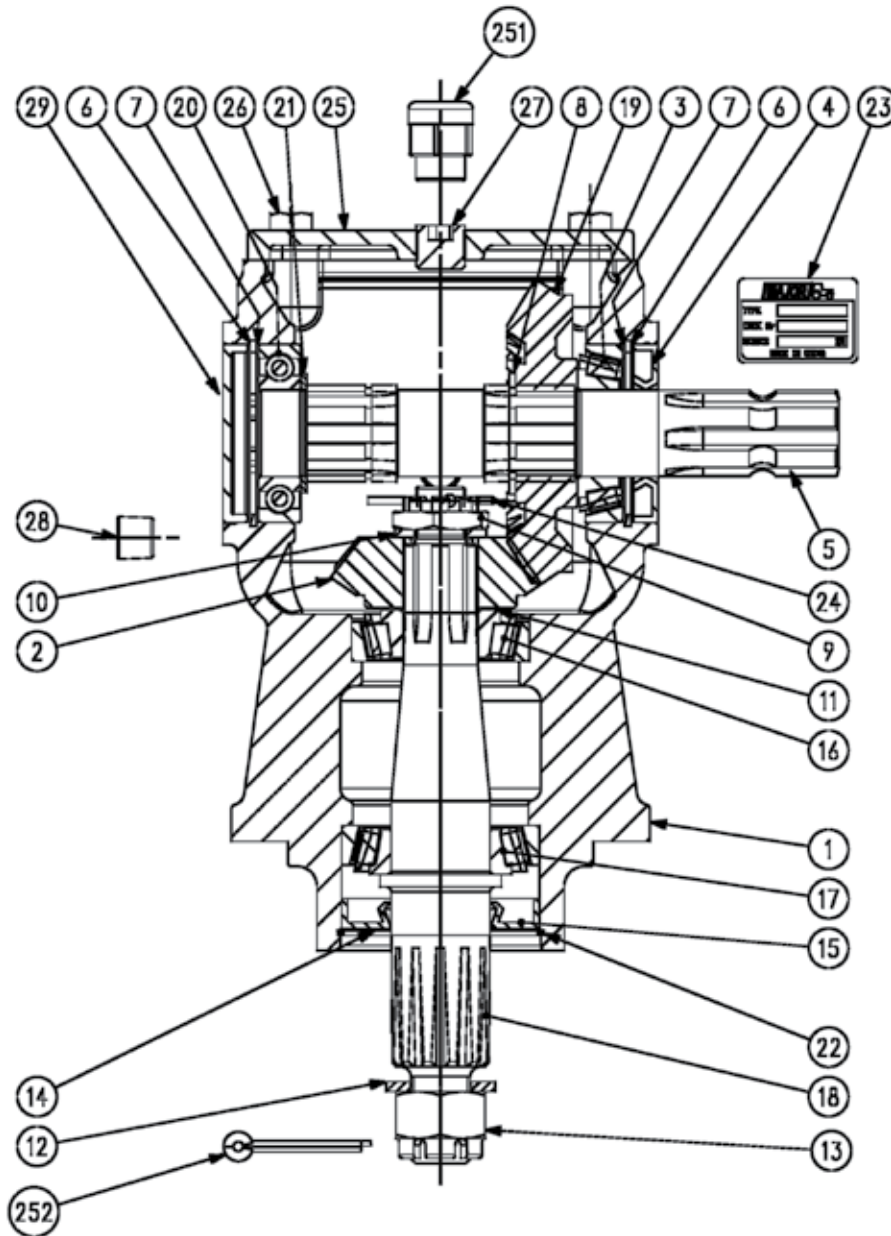

Item	Part No	Description	Qty
1	0.347.0300.00	Casting and Machining	1
2	UO.040.5004.00	Gear Pinion Z15 M5.5	1
3	8.09.00026	Roller Bearing 30207 (35x72x18.25)	1
4	8.7.3.00055	Oil Seal (35x72x10)	1
5	0.347.3002.00	Through Shaft 1 3/8 Z6	1
6	8.5.2.00131	Snap Ring (72x75x2.5 , For Holes)	2
7	0.248.7500.00	Shim Kit (60.3x71.7)	2
8	8.5.1.00680	Snap Ring (40x37.5x2.5 , For Shafts)	1
9	0.289.7102.02	Castle Nut (M20X1)	1
10	8.3.2.00531	Flat Washer (21x37x3)	1
11	0.102.7500.00	Shim Kit (30.3x44)	1
12	LF135-2	Flat Washer (25x44x4)	1
13	LF135-1	Castle Nut (M24x2)	1
14	1.135.7100.00	Protective Flat Washer (40.4x79.9x1)	1
15	8.7.1.00748	Dust Lip (40x80x12)	1

16	8.0.9.01049	Roller Bearing 30306 (30x72x20.75)	1
17	8.0.9.00024	Roller Bearing 30208 (40x80x19.75)	1
18	UO.040.3006.01	Output Shaft ASA D.P. 8/16 Z12	1
19	UO.040.6004.00	Gear Crown Z22 M5.5	1
20	8.0.1.00870	Ball Bearing 6207 (35x72x17)	1
21	0.259.7525.00	Shim (35.3x48x2.5)	1
22	8.5.3.00955	Snap Ring SB 81 (81x82.8x2)	1
23	0.205.7100.00	"Major" Name Plate	1
24	8.4.7.00823	Cotter Pin (4x40)	1
25	0.347.1300.00	Top Cover	1
26	8.11.00061	Bolt M10x25 HHB (8.8)	4
27	8.6.6.00088	1/2" Gas Solid Plug	1
28	8.6.6.00201	3/8" Gas Oil Level Plug	1
29	8.7.0.00744	Oil Cap (72x10)	1
251	8.6.7.00269	1/2" Gas Oil Breather Plug	1
252	8.4.7.00516	Cotter Pin (5x50)	1

MJ40T-347.801-1.47

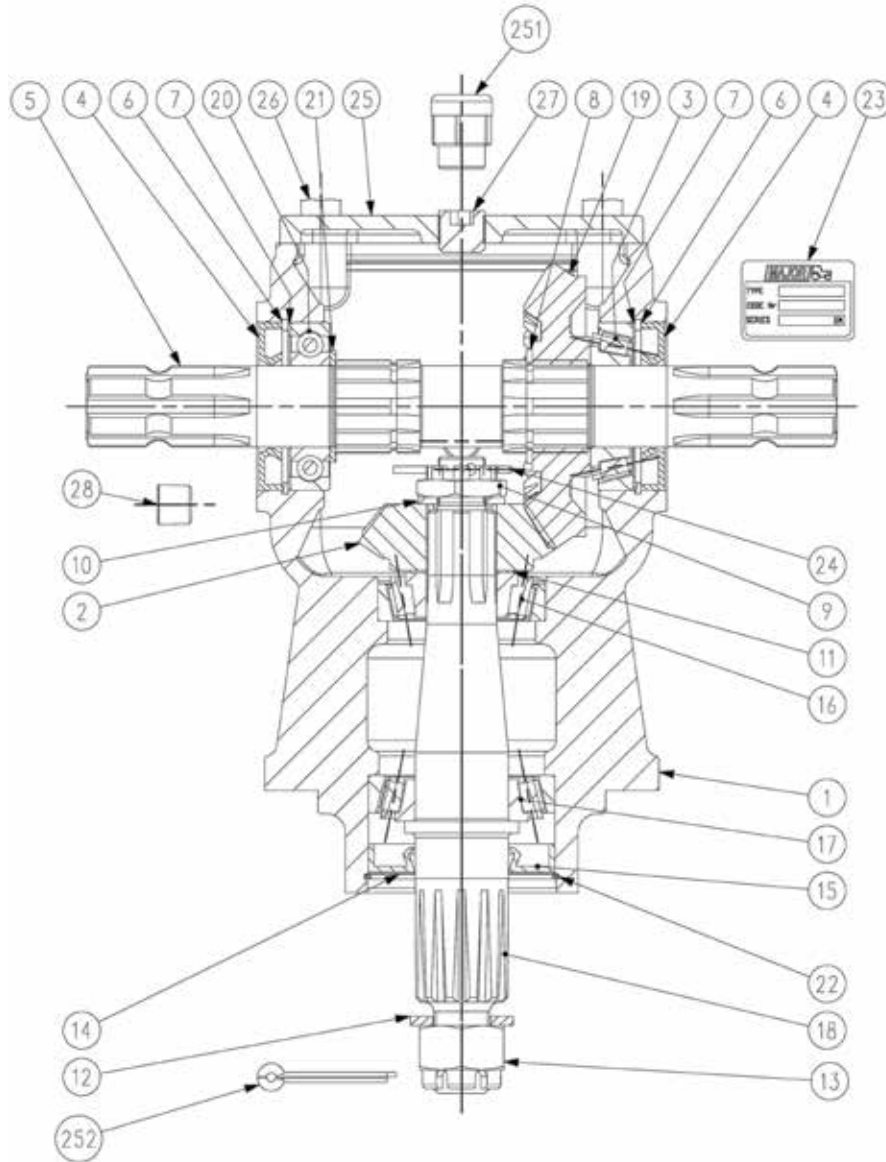

Item	Part No	Description	Qty
1	0.347.0300.00	Casting and Machining	1
2	U0.040.5004.00	Gear Pinion Z15 M5.5	1
3	8.0.9.00026	Roller Bearing 30207 (35x72x28.25)	1
4	8.7.3.00055	Oil Seal (35x72x10)	2
5	0.347.3000.00	Through Shaft 1"3/8 Z6 - 1"3/8 Z6	1
6	8.5.2.00131	Snap Ring (72x75x2.5 , For Holes)	2
7	0.248.7500.00	Shim Kit (60.3x71.7)	2
8	8.5.1.00680	Snap Ring (40x37.5x2.5 , for shafts)	1
9	0.289.7102.02	Castle Nut (M20x1)	1
10	8.3.2.00531	Flat Washer (21x37x3)	1
11	0.102.7500.00	Shim kit (30.3x44)	1
12	LF135-2	Flat Washer (25x44x4)	1
13	LF135-1	Castle Nut (M24x2)	1

14	1.135.7100.00	Protective Flat Washer (40.4x79.9x1)	1
15	8.7.1.00748	Dust Lip (40x80x12)	1
16	8.0.9.01049	Roller Bearing 30306 (30x72x20.65)	1
17	8.0.9.00024	Roller Bearing 30208 (40x80x19.75)	1
18	U0.040.3006.01	Output Shaft ASA D.P. 8/16 Z12	1
19	U0.040.6004.00	Gear Crown Z22 M5.5	1
20	8.0.1.00870	Ball Bearing 6207 (35x72x17)	1
21	0.259.7525.00	Shim (35.5x48x2.5)	1
22	8.5.3.00955	Snap Ring SB 81 (81x82.8x2)	1
23	0.205.7100.00	"Major" Name Plate	1
24	8.4.7.00823	Cotter Pin (4x40)	1
25	0.347.1300.00	Top Cover	1
26	8.1.1.00061	Bolt M10x25 HHB (8.8)	4
27	8.6.6.00088	1/2" Gas Solid Plug	1
28	8.6.6.00201	3/8" Gas Oil Level Plug	1
251	8.6.7.00269	1/2" Gas Oil Breather Plug	1
252	8.4.7.00516	Cotter Pin (5x50)	1

T27A - 267.245 - 1.92

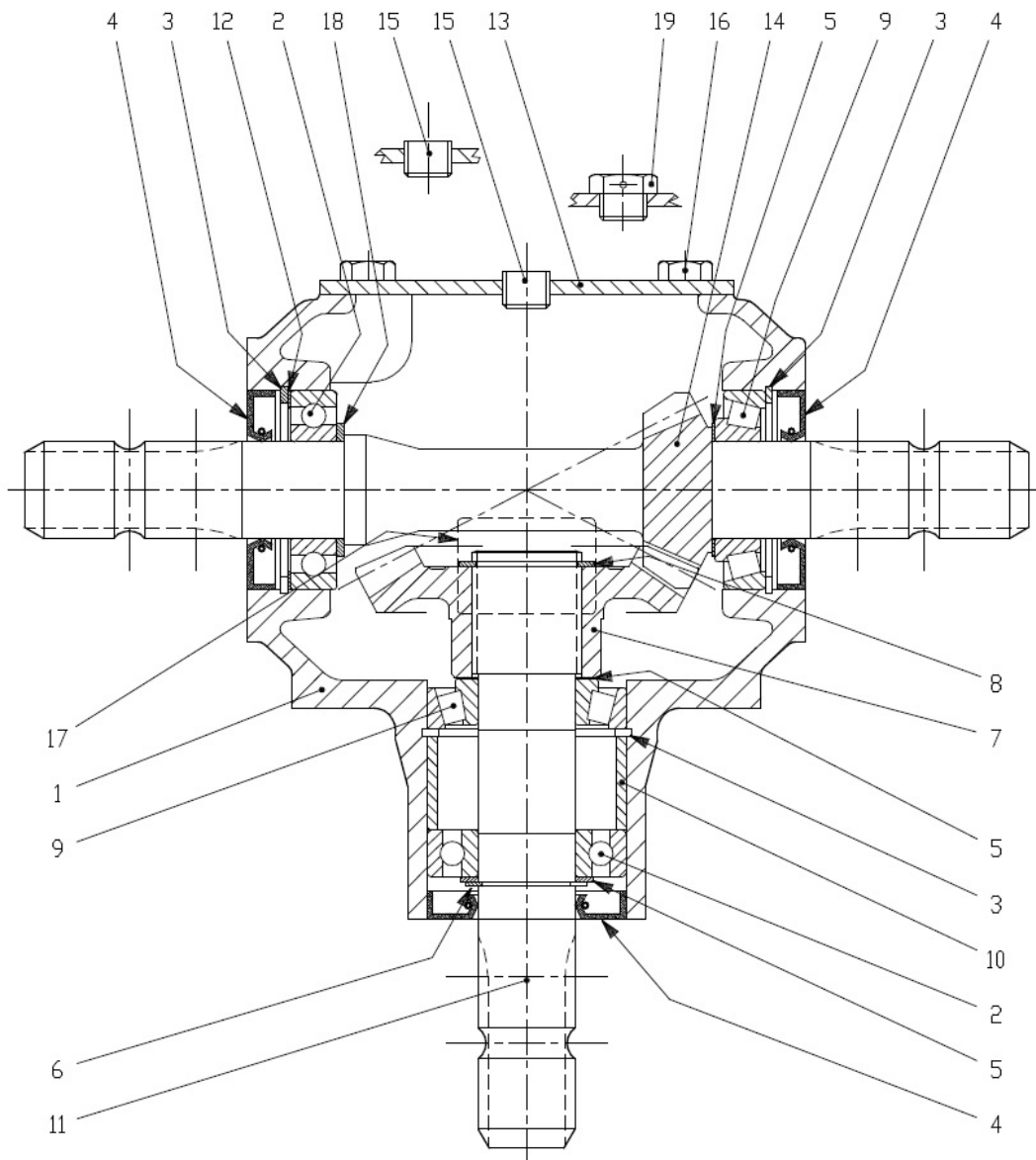

Item	Part No		Description	Qty
1	T27/12	0.267.0300.00	CASING	1
2	T4A/6	8.0.1.00870	BEARING 6207	2
3	T27/2	8.5.2.00131	SNAP RING 72 UNI7437	3
4	T27/1	8.7.3.00055	OIL SEAL 35X72X10	3
5	T4A/4	0.259.7500.00	SHIM 35.3x48.0	3
6	LF135/7	8.5.1.00005	SNAP RING 35 UNI7435	1
7	T27/9	0.121.6000.00	CROWN WHEEL Z23 M5.3	1
8	T4A/2	8.5.1.00029	SNAP RING 40 UNI7435	1
9	T27/8	8.0.9.00026	BEARING 30207	2
10	T27/5	0.267.7100.00	SPACER	1
11	T27/6	0.267.2209.00	SHAFT 1"3/8	1
12	T4A/5	0.248.7500.00	SHIM 71.7	1
13	T27/13	0.267.1302.00	COVER	1
14	T27/16	0.267.6206.00	PINION Z12 M5.30	1
15	T4A/10	8.6.6.00201	PLUG 3/8"GAS	2
16	N/A	8.1.1.00054	BOLT M10X20 8,8	4
17	N/A	0.124.7101.00	PLATE	1
18	T4A/5	0.259.7525.00	SHIM 35.3x2.5	1
19	T27/17	0.107.7100.01	OIL FILLER PLUG	1

T304 - 304.601 - 2.54

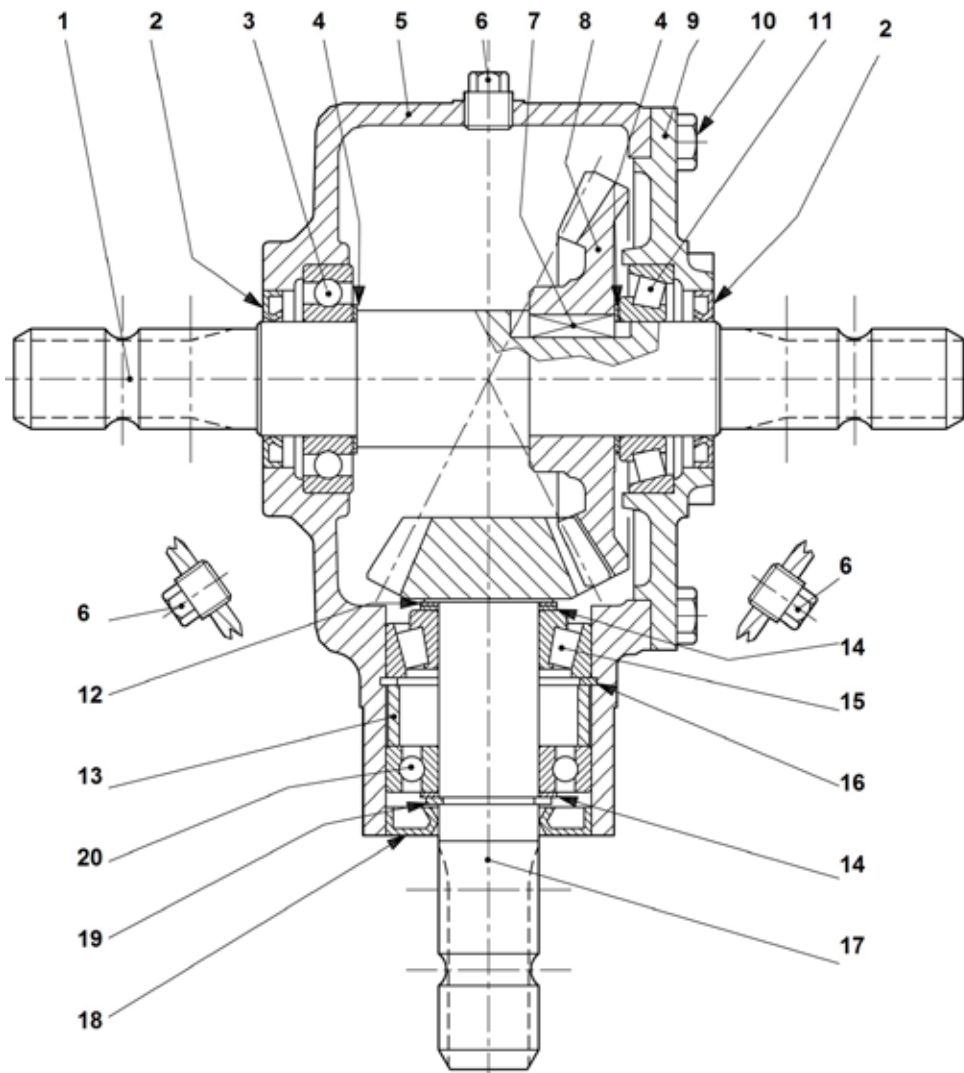

Item	Part No		Description	Qty
1	T-304A/15	0.244.47208.00	Shaft	1
2	T-4A/12	8.73.00603	Oil Seal	2
3	T-4A/13	8.0.9.00024	Bearing 6208 (LF135/9)	1
4	LF135/8	0.244.7500.00	Shim	2
5	T-304A/11	0.244.0511.00	Casing	1
6	LF135/13	8.6.6.00201	Plug	3
7	T-304A/16	8.4.1.00057	Parallel Key	1
8	T-4A/17	0.244.62003.00	Gear Z29	1
9	T-304A/20	0.244.1316.00	Cover	1
10	T-4A/21	8.1.1.00041	Bolt M12x25B	6
11	T-4A/18	8.0.9.00024	Bearing 30208	1
12	T-4A/4	0.259.7500.00	SHIM 35.3x48.0	2
13	T-304A/7	0.244.7121.00	Spacer	1
14	T4-A/5	0.248.7500.00	Shim Kit (60.3x71.7)	1
15	T-4A/8	8.0.9.00127	Bearing 32207	1
16	T-4A/3	8.5.2.00131	Snap Ring	1
17	T-304A/9	0.244.5206.00	Pinion Shaft Z15 M5	1
18	T-4A/1	8.7.3.00055	Oil Seal 25x72x10	1
19	T-4A/19	0.247.7201.00	Gasket	1
20	T-4A/6	8.0.1.00025	Bearing 6207 (LF135/15)	1
21	T-4A/2	8.5.2.00131	Snap Ring UNI7435	1

LF140J-140.886-1 (140.881)

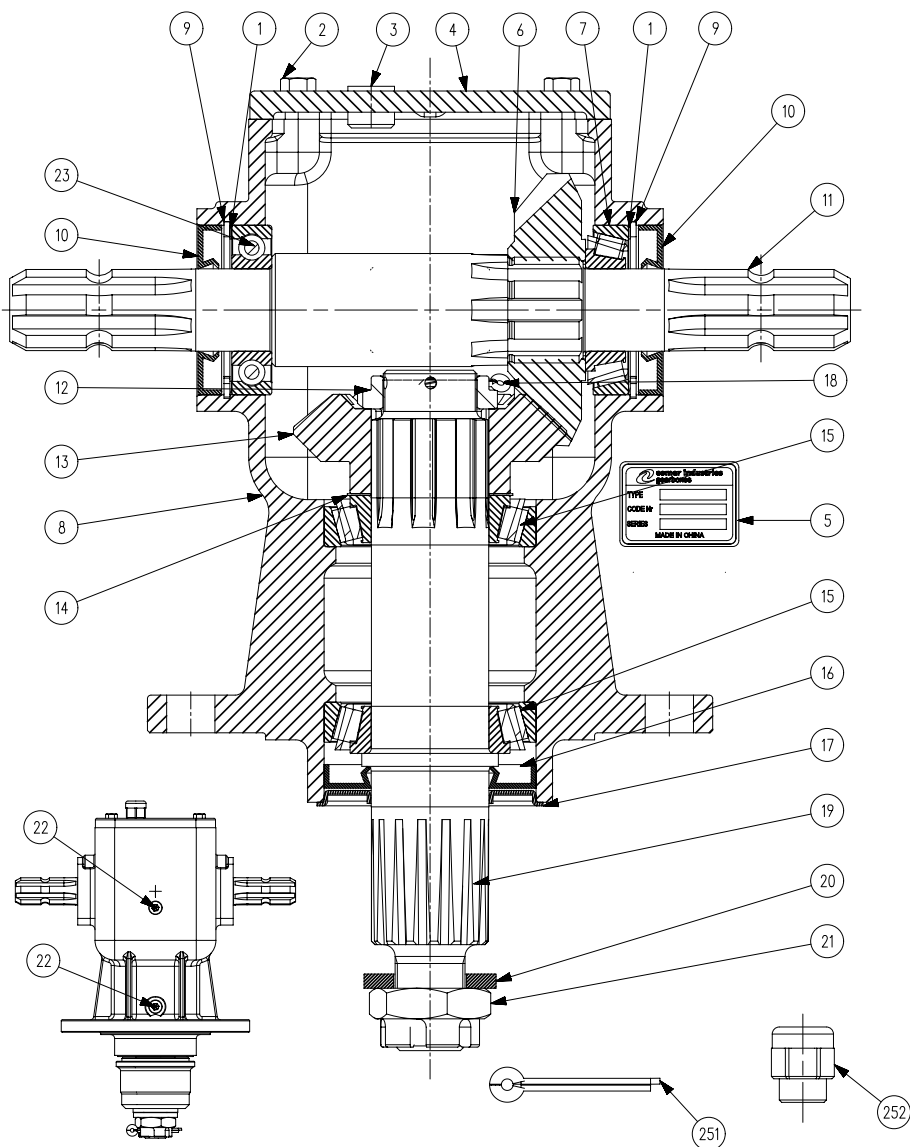

Item	Part No	Description	Qty
1	0.248.7500.00	SHIM KIT 60.3x71.7	2
2	8.1.1.00041	BOLT M8X22 8,8	4
3	8.6.6.00088	PLUG 1/2"GAS	1
4	0.140.1302.00	COVER	1
5	0.124.7135.00	NAME PLATE	1
6	0.132.5002.00	GEAR Z18 M6.15	1
7	8.0.9.00026	BEARING 30207	1
8	0.140.0303.00	CASING	1
9	8.5.2.00131	SNAP RING HOLE 72 UNI7437	2
10	8.7.1.00152	DUST LIP SEAL 35X72X10	2
11	0.140.2007.00	SHAFT 1" 3/8	1
12	0.132.7107.00	CASTLE NUT M40X1.5	1
13	0.132.6002.00	GEAR Z18 M6.15	1

14	0.712.7500.00	SHIM KIT 50.3x70.3	1
15	8.0.9.00469	TAPER ROLLER BEARING 30210	2
16	8.7.1.01107	DOUBLE LIP SEAL 50X90X10	1
17	0.139.7100.00	PROTECTIVE WASHER	1
18	8.4.7.01112	COTTER PIN B4X60	1
19	0.140.3003.00	SHAFT	1
20	0.139.7101.00	BLANK WASHER	1
21	0.140.7102.00	NUT M30X2	1
22	8.6.6.00201	PLUG 3/8"GAS	2
23	8.0.1.00870	BALL BEARING 6207	1
251	8.4.7.00146	COTTER PIN B6X60	1
252	8.6.7.00269	BREATHER PLUG 1/2"GAS	1

T292B-292.005-1.47

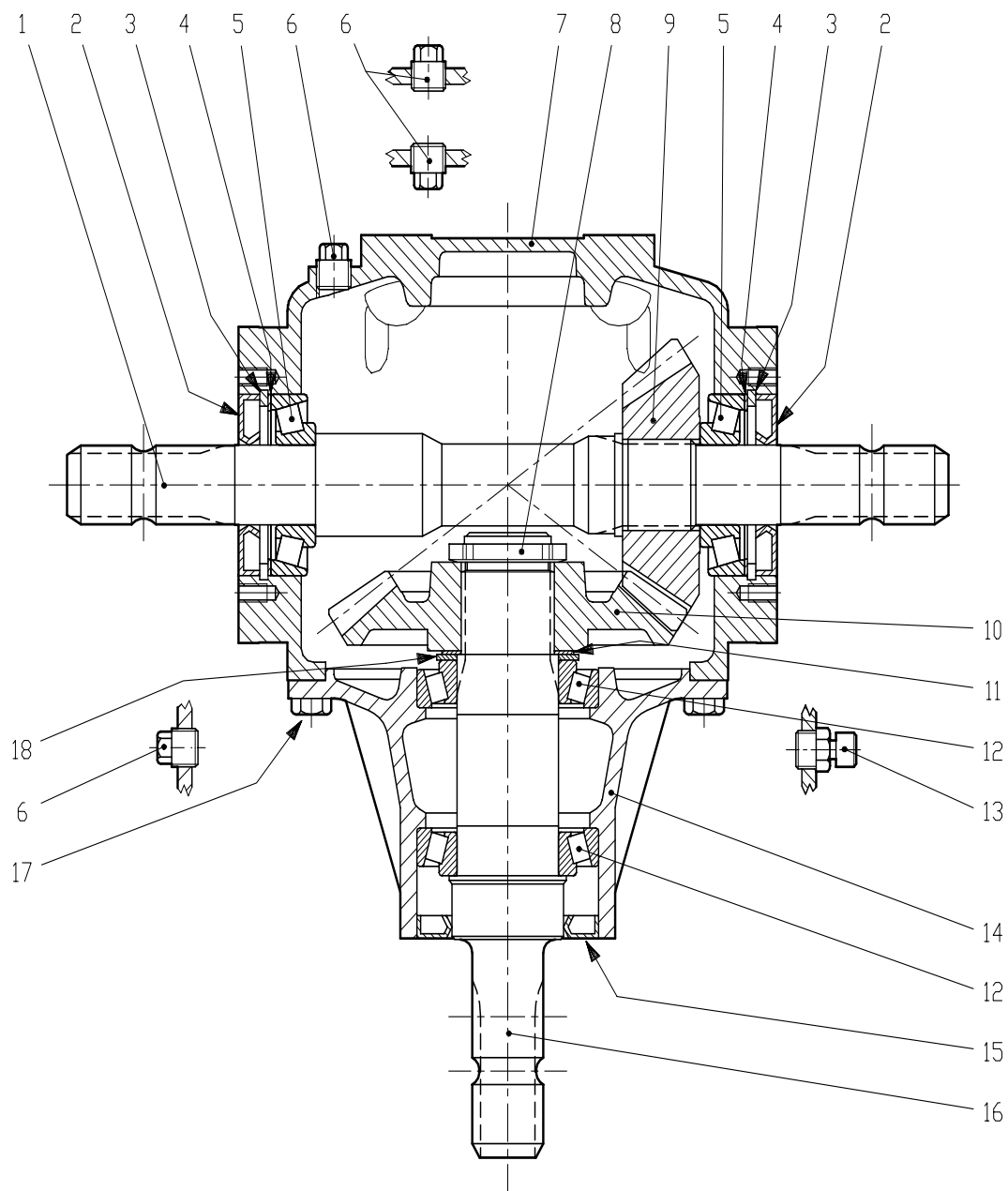

Item	Part No	Description	Qty
1	0.292.3000.00		1
2	8.7.3.00081		2
3	8.5.2.01370		2
4	0.110.7500.00		2
5	8.0.9.00129		2
6	8.6.5.00006		4
7	0.292.0301.00		1
8	0.278.7103.00		1
9	0.272.6001.00		1
10	0.272.5001.00		1
11	0.350.7500.00		1
12	8.0.9.00469		2
13	8.6.7.00161		1
14	0.292.1310.00		1
15	8.7.3.01296		1
16	0.292.2001.00		1
17	8.1.1.00501		8
18	0.712.7525.00		1

All MAJOR machines must be registered when sold, to ensure that you receive the correct warranty cover and service bulletins. To register your machine for warranty, please go to the SALES & SUPPORT section of our website www.major-equipment.com and enter your details.

The Grass & Slurry Machinery Specialists | Agricultural - Professional Groundscare - Industrial

MAJOR

HOME PRODUCTS ABOUT NEWS FIND A DEALER SHOP SALES & SUPPORT CONTACT

How To Videos
Financing
Request a Demo
Technical Publications
Brochures
Register your Machine
Frequently Asked Questions

Register your Machine

Product Registration Form

Please register your machine to ensure you get the correct warranty cover and service bulletins. Please provide your full postal address.

Name * **Email ***

Address *

Address 1

Address 2



Get In Touch

Head Office

Major Equipment Intl Ltd

Ballyhaunis, Co. Mayo, F35 C891, Ireland

Tel: + 353 (0) 9496 30572

info@major-equipment.com

UK Office

Major Equipment Ltd

Major Ind. Estate, Heysham, Lancs, LA3 3JJ, UK

Tel: + 44 (0) 1524 850501

ukinfo@major-equipment.com

Netherlands Office

Major Equipment Intl Ltd (EU)

Postbus 29, NL-7700 AA Dedemsvaart, Nederland

Tel: + 31 (0) 6389 19585

euinfo@major-equipment.com

@MAJOREQUIPMENT



www.major-equipment.com