

Operator Manual & Parts List

MAJOR RANGE OF
FLEX WING TOPPERS

12000FW-HD and 18000FW-HD



Head Office

Major Equipment Intl. Ltd.
Ballyhaunis,
Co. Mayo,
Ireland.

Tel.: +353 (0) 9496 30572
Fax: +353 (0) 9496 30788
Email: info@major-equipment.com

UK Office

Major Equipment Ltd.
Major Industrial Estate,
Middleton Rd.,
Heysham,
Lancs.
LA3 3JJ

Tel.: +44 (0) 1524 850 501
Fax: +44 (0) 1524 850 502
Email: ukinfo@major-equipment.com

NETHERLANDS & GERMANY OFFICE

Major Equipment Intl. Ltd.
Postbus 29,
NL-7700 AA ,
Dedemsvaart,
Nederland.

Tel: +31 (0) 6389 19585
Email: euinfo@major-equipment.com

Web: www.major-equipment.com



Find us on FACEBOOK
MAJOR MACHINERY



View our channel
MAJOREQUIPMENT

Disclaimer

While every effort has been made in the production of this manual to ensure that the information contained herein is full and correct, Major assumes no responsibility for errors or omissions.

Major reserves the right to modify the machinery and the technical data contained within the manual without prior notice.

Further to this, Major assumes no liability for any damages which may result from the use of the information contained within this manual.

Contents

Introduction

Thank you	1
Using Your Operator's Manual	1
Safety Aspects	1
Intended use	1

Product Identification

Machine Serial Numbers	1
Register Your Product and Warranty Online	1
Product Specifications	2

Safety

Machine Safety Labels	2
Hazards	3
Operating Safely	4
Workstation	4
Regulations for use of the transmission	4
PTO Shaft Safety	5
Driving Safely on Public Roads	5

Operating the Machine

Inspections before Use	6
Key to Main Parts	7
Starting Regulations	7
Hitching to the Tractor	7
Operating the Machine/Mowing	9

Maintenance

PTO Shaft Maintenance	9
Blade Rotation	10
Maintenance Schedule	10
Trouble Shooting	11

Spare Parts - Flex Wing

Flex Wing Topper Overview	12
12000FW-HD and 18000FW-HD body assembly	13
12000FW-HD wing	14
18000FW-HD wing	14
Castor wheel	15
Blade Systems	16
Gearboxes	18
Flex Wing Hydraulics	22

EEC certificate of conformity for machines

(conforming to Directive 98/37/EEC)

Company: Major Equipment Ltd.
Address: Coolnaha,
Ballyhaunis,
Co. Mayo,
Ireland.
Tel. +353949630572
Fax +353949630788

declares in sole responsibility that the product:

FLEX WING GRASS TOPPER

When properly installed, maintained and used only for it's intended purpose, complies with all the essential Health & Safety requirements of:

- **THE SUPPLY OF MACHINERY (SAFETY) REGULATIONS 2008.**
- **S.I. No. 299 of 2007**, Safety, Health and Welfare at Work (General Application) Regulations 2007 (Ireland).
- **Health & Safety at Work, etc. Act 1974 (c.37) (UK).**
- **EN ISO 14121-1: 2007** 'Safety of machinery. Principles for risk assessment'.
- **EN 745** - Agricultural Machinery - Rotary Mowers and Flail Mowers - Safety.
- **EN ISO 13857** - Safety of machinery: Safety distances to prevent hazard zones being reached by upper and lower limbs.

I certify on behalf of Major Equipment Int. Ltd., that this machine when properly installed and operated correctly, complies with all the essential Health & Safety requirements of all legislation referred to above.

Signature : 

Managing Director

Date 12/06/2013

Introduction

Thank you

We appreciate having you as a customer and wish you many years of safe and satisfied use of your machine.

Using Your Operator's Manual

This manual is an important part of your machine and should remain with the machine when you buy it. Reading your operator's manual will help you and others avoid personal injury or damage to the machine. Information given in this manual will provide the operator with the safest and most effective use of the machine.

Sections in your operator's manual are placed in a specific order to help you understand all the safety messages so you can operate this machine safely. You can also use this manual to answer any specific operating or servicing questions.

Safety Aspects

Your manual contains special messages to bring attention to potential safety concerns, machine damage as well as helpful operating and servicing information. Please read all the information carefully to avoid injury and machine damage.

Intended use

This machine is a grass cutting machine and designed for cutting grass. Moreover, it must only be used with a suitable tractor (see "Product Specifications" section of this booklet) and driven by an adequate drive-line of the tractor PTO. All other use is strictly prohibited.

Product Identification

Machine Serial Numbers

If you need to contact MAJOR or your MAJOR dealer for information on servicing or spare parts, always provide the product model and serial numbers. Model and Serial number can be found on the Serial Plate located on the machine.

We suggest that you record your machine details below:

Model No: _____

Serial No: _____

Date of Purchase: _____

Dealer Name: _____

Dealer Telephone: _____



Register Your Product and Warranty Online

To register your product through the Internet, simply go to the Support section on www.major-equipment.com. Completing the information, either online or with the product warranty card, will ensure the customer that their product receives all post sales service and important product information.

This machine is warranted for 12 months with. No warranty is given where the machine is being used as a hire machine. Warranty is against faulty workmanship or parts.

Warranty covers parts only. All parts must be returned to the manufacturer. No warranty can be considered unless parts are returned. All replacement parts will be supplied on a chargeable basis until warranty has been accepted.

Product Specifications

Model	12000FW-HD	18000FW-HD
Overall Width	3.8m (12' 4")	5.6m (18' 4")
Working Width	3.56m (12')	5.38m (18')
Transport Width	2.2m (7' 2")	2.2m (7' 2")
No. of Blades	16	24
No. of Rotors	4	6
Power (HP)	50 - 75	60 -90
PTO (rpm)	540	540
Blade tip speed	74m/s	74m/s
Cutting Height	12-250mm	12-250mm
Weight	1116kg	1395kg

Safety

Machine Safety Labels

The machine safety labels shown in this section are placed in important areas on your machine to draw attention to potential safety hazards.

On your machine safety labels, the words DANGER, WARNING, and CAUTION are used with this safety alert symbol. DANGER identifies the most serious hazards.

The operator's manual also explains any potential safety hazards whenever necessary in special safety messages that are identified with the word, CAUTION, and the safety-alert symbol



To avoid injury, read the manual

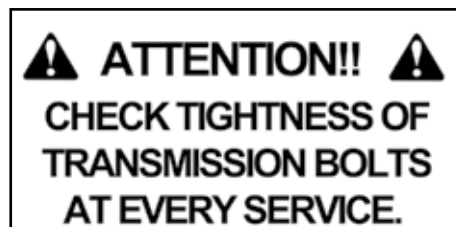

Check the tightness of the transmission



PTO entanglement hazard - keep clear of PTO drives.

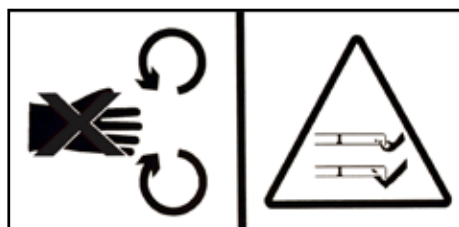

Rotating blade hazard

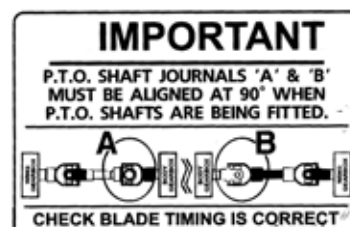

Shaft alignment



Maximum speed



- High pressure oil easily punctures skin causing serious injury, gangrene or death.
- If injured, seek emergency medical help, immediate surgery is required to remove oil.
- Do not use finger or skin to check for leaks.
- Lower load or relieve hydraulic pressure before loosening fittings.

High oil pressure hazard



Grease points



Moving parts

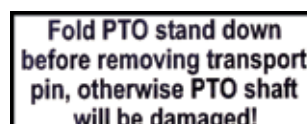

Hazards associated with operating Grass Cutting Machinery

Shear Hazard

Shear hazards are created when the edges of two objects move toward or next to each other closely enough to cut relatively soft material. This can include the parts of the machine under hydraulic control when operating from transport to mowing position. Note, the wing units are designed to float independently of the centre deck & are free to move within operating limits.

Crush Hazard

Bystanders can be injured when machine is lowered into mowing position. Winged machines have crush points around the hinge areas & between the wing & main body. Always use transport locking bars when not in use (winged models only).

Rotating Blade Hazard

All persons are at risk if they place their hands or feet under the machine when it is raised from the ground when the blades are in motion.

Pinch Hazard

Pinch points are created when two objects move together, with at least one of them moving in a circle. This hazard is common in power transmission devices such as Belt Drives, Gear Drives & Rollers. Ensure all guarding is present.

Wrap Hazard

Any exposed, rotating machine component is a potential wrap point. Injuries usually occur when loose clothing or long hair catch on and wrap around rotating parts such as PTO shafts or Drive shafts on the machine. Ensure all guarding is present.

Free-wheeling parts Hazard

The heavier a revolving part is, the longer it will continue to rotate after power is shut off. This characteristic is called 'free-wheeling.' Blades, and various other components, drive shafts etc., will continue to move after power is shut off - often for several minutes. Injuries occur when:

- Operators shut off equipment, and attempt to clean or adjust a machine before components have completely stopped moving.
- Shear bolt protection device in PTO shaft shears & the mowing parts are still spinning but the primary PTO shaft is stationary. Operator awareness is the key to safety around freewheeling parts. Never raise the machine while the blades are still rotating.

Thrown objects Hazard

Machines throw material as a natural part of doing their job. Foreign objects, such as stones, sticks and other debris, may be taken into this equipment and expelled at tremendous speed. These objects are contained by the sides of the machine and by the rear/front rollers / guards / chain guards / rubber skirts depending on model of your machine.

Ensure bystanders are clear from the machine & cannot be hit with debris expelled from the machine. Bystanders or animals in the path of thrown objects could be seriously injured. Never operate machine with decks raised from the ground as this makes the front/rear protection redundant.

Hydraulic Hazard (if applicable)

Hydraulic systems store considerable energy. Careless servicing, adjustment, or replacement of parts can result in serious injury. High pressure blasts of hydraulic oil can injure eyes or other body parts. The following precautions are crucial:

- Make certain the hydraulic pump is turned off.
- Lower attached equipment to the ground.
- Confirm that load pressure is off the system.

A pinhole leak in an hydraulic hose is a serious hazard. A leak may not be visible, and the only sign may be a few drops of fluid. Never inspect hydraulic hoses with your hands, because a fine jet of hydraulic fluid can pierce the skin.

Slips, Trips and Falls Hazard

Slips and falls often result from:

1. Slippery footing on the ground
2. Cluttered steps and work platforms.

The potential for slips and falls can be greatly reduced by using good judgement and practicing good housekeeping on and around equipment.

Noise Hazard

Please note that the machine is normally used outdoors and that the position of the operator is seated in the driving seat of the tractor. It is advisable to consult the prescriptions listed in tractor operator and maintenance manuals.

The acoustic pressure at a distance of 2.6m from the centre of the machine and at a height of 2.0m, with the implement operating in a no load condition can reach 90 dBA. In a loaded condition & a PTO rate of 540 rpm the value can reach 97dBA. Higher rate of PTO input will result in in higher noise levels. Always wear hearing protection.

Operating Safely

This MAJOR machine is designed to operate at a PTO rate which is stated in the Product Specifications part of this booklet. Ensure tractor PTO output is set at a correct RPM rate. This MAJOR machine must only be used for purposes outlined in the Intended Use section of this booklet. All other use is strictly prohibited.



Users should become thoroughly familiar with the contents of this manual before using, servicing and mounting the implement to the tractor and all other pertinent operations. Never wear jewellery, loose clothing such as ties, scarves, belts, unbuttoned jackets or dungarees with open zips which could become caught up in moving parts.



Always wear approved garments complying with accident prevention provisions such as non-slip shoes, ear muffs, goggles and gauntlets. Wear a jacket with reflecting stickers if the implement is used near public highways.



Consult your retailer, the Labour Health Service or your nearest equivalent authority for the information about the current safety provisions and specific regulations with in order to ensure personal safety.



ALWAYS DISENGAGE PTO, SWITCH OFF THE TRACTOR ENGINE AND ENGAGE THE PARKING BRAKE BEFORE MAKING ADJUSTMENT TO THE MACHINE.



NEVER PLACE LIMBS UNDER THE MACHINE WHILE ROTOR(S) ARE TURNING. ROTOR(S) CAN REMAIN TURNING FOR UP TO 1 MINUTE AFTER DISENGAGING PTO.

Workstation

The operator must remain seated while working the machine. If the machine is a winged unit and the wings need to be raised/lowered the operator must not leave the tractor. Always ensure the PTO has been turned off and the parking brake applied before leaving the tractor cab or carrying out maintenance.



NEVER OPERATE THE HYDRAULICS WITH THE TRACTOR SWITCHED OFF

Regulations for use of the transmission

The transmission to the gearboxes is protected throughout the machine by both PTO shafts and bolt down covers. All guarding should be kept efficient and in good condition. If the condition is poor, the guarding should be renewed before the implement is used.



UNLESS IT IS CORRECTLY PROTECTED THE TRANSMISSION COULD CAUSE DEATH SINCE IT CAN CATCH ON PARTS OF THE BODY OR CLOTHING

Ensure retaining chains are correctly anchored on all PTO shafts, preventing them from turning. Ensure drive line can turn easily within the shield. Keep spline grooves clean and greased so that PTO shaft can connect easily. Besides being described in this booklet, the method by which the PTO shaft is connected to the tractor must be checked out with the instructions in the tractor manufacturer's manual.

PTO Shaft Safety

Maximum PTO input is specified in the Product Specifications section of this booklet. Contact your nearest dealer or a specialised retail outlet if the PTO must be replaced with a longer one, since this must belong to the same power category and possess the same characteristics. An unsuitable PTO could easily break.

The tractor PTO shaft length may be altered to suit the individual tractor model. When the machine is in operation, the PTO shaft should have a minimum 1/3 engagement as shown in the diagrams. After the machine has been hitched to the tractor, it should be checked in various positions that the drive line is the correct length. If the PTO is too short and tends to slip out of place, it must be replaced with a longer one.

If the PTO shaft is too long, it should be shortened in the following way:

- Set the machine at a minimum distance from the tractor, then brake the tractor and switch off the engine.
- Separate the two halves of the PTO. Insert the female part into the tractor PTO and the male part into the machine PTO, checking that the position is correct by means of the fixing pins.
- Line up the two halves of the PTO together, keeping them parallel.
- Using a felt tip pen, match mark the place where the two halves must be shortened as shown.
- First cut shield "1" and use part "2" as a reference to cut the splined shaft.
- Proceed in the same way for the second half.
- Trim and chamfer the two cut ends of the PTO and clean off all swarf and shavings.
- Grease the two profiles and join the two halves of the PTO together.
- Mount the PTO shaft and check that its length is correct as before.

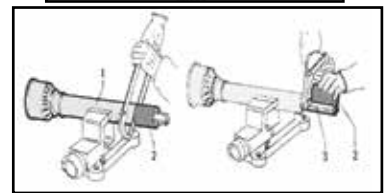
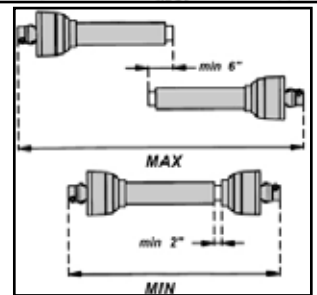
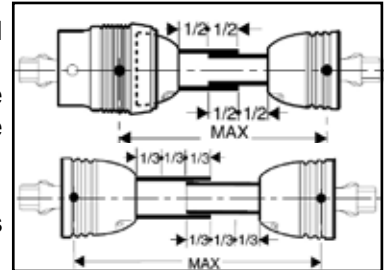

Trailed machine operation.

Ensure that the PTO doesn't catch the wheel of the tractor when turning sharply.

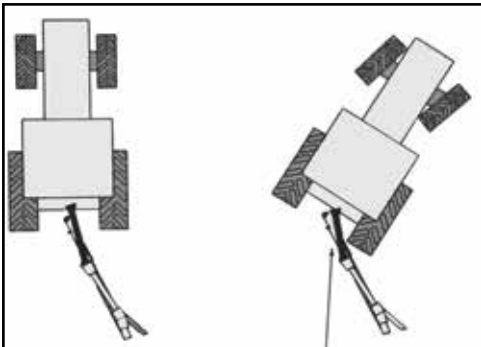

Driving Safely on Public Roads

Check the local Highway Code regulations before driving the tractor on public highways with an implement attached. Check the reflectors, hazard flashers and/or projecting load indicators are installed when required and efficient. These indicators must be installed correctly and easily seen by the drivers of other vehicles.

Bystanders must not be allowed to lean against or climb onto the machine during transport or while working. Do not allow bystanders to ride on the machine.



MAXIMUM TRANSPORT SPEED MUST NOT EXCEED 30 km/hr (18 MPH)

General safety instructions

Precautions to be taken while working with the machine:

1. Do not operate the machine when you are tired;
2. Before starting mowing, make sure that the area is clear of people or animals.
3. Before starting adjusting the machine, it is mandatory to disconnect the PTO, to turn off the engine of the tractor, apply handbrake and wait for the turning parts to become still and placed on the ground.
4. It is mandatory to read all the safety requirements and the operator's manual of the machine.
5. If you are not sure how to use the machine, please contact the manufacturer or the dealer.

Operating the Machine

Inspections before Use



Always disengage PTO, Switch off tractor engine and engage the parking brake before making adjustments to the machine.

1. With the whole machine as level as possible, check the oil level in the Primary Gearbox, top up as required with SAE EP90 gear oil through the oil filler plug indicated. The correct level is at the oil level plug indicated. Check the oil level in the Rotor Gearboxes and top up as required with SAE EP 90 gear oil through the oil filler plugs indicated. The correct level is at the oil level plug indicated

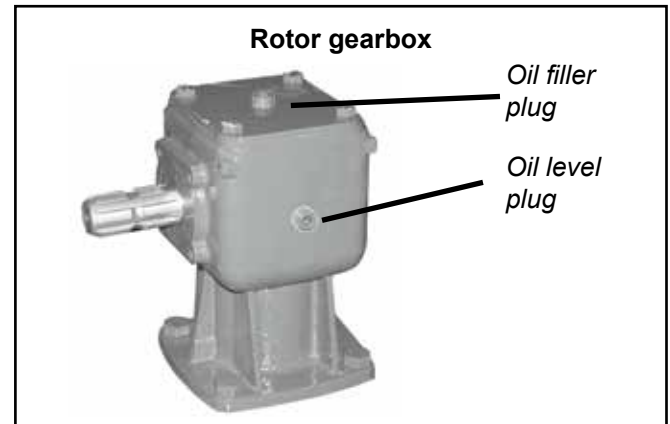
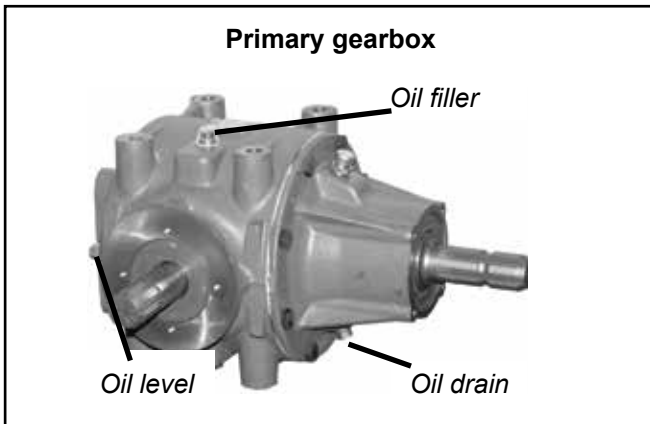

2. Grease the PTO shaft universal joints, drive shaft bearing and carrying arm pivots.
3. Re-sharpen old blades with a grindstone if necessary. Replace bent blades with new ones.
4. Check the blade mounting bolts are tight

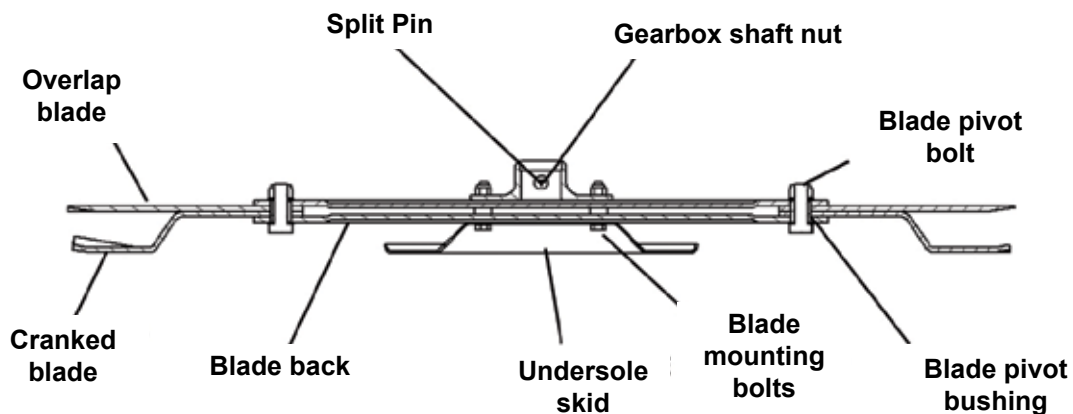

5. Ensure the gearbox shaft nuts are tight and retained in place by split pin.
6. Check tightness of all nuts, bolts and retaining screws after the first and second hours of work.
7. Ensure safety guards and flaps are in place at all times where fitted.
8. Due to the corrosive nature of grass when cut, wash down the machine when finished mowing, especially when the machine is being stored for a long period of time.

Key to Main Parts

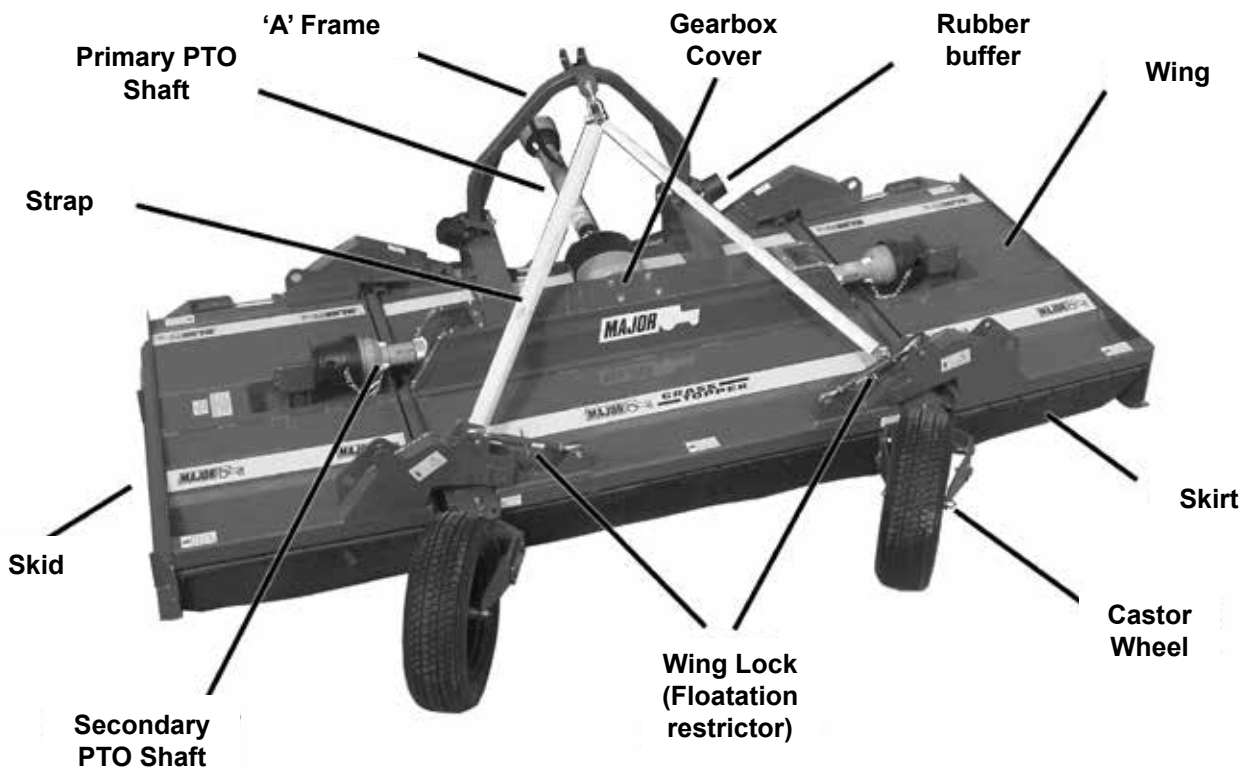

Starting Regulations



Always check that any imminently dangerous conditions have been eliminated before using the machine. Ensure all guarding is present & the operator is fully aware of the operations of the machine



Always ensure the pins lock the PTO shaft yoke ends onto the spline shafts on both the tractor and the implement. An unlocked shaft could slip out of position, causing notable mechanical damage and serious injury to both operator and bystanders.

Hitching to the Tractor

ALWAYS OPERATE ON LEVEL GROUND WHEN HITCHING/UNHITCHING THE IMPLEMENT. THIS WILL PREVENT DANGEROUS MOVEMENT. NEVER ALLOW ANYONE TO STAND BETWEEN THE TRACTOR AND THE MACHINE.

1. Reverse the tractor, connect the hitch & secure in position with correct size drawbar pin. Ensure the tractor parking brake is applied.
2. Connect the machine to the tractor,
3. Before connecting the PTO shaft to the tractor, check for length as previously described in this manual.
4. Ensure shear-bolt safety device is fitted on the machine PTO shaft and not the tractor PTO, as shown on the PTO shaft guarding.
5. Ensure PTO check chains are anchored to prevent PTO guarding from rotating.
6. Connect the hydraulic hoses to the appropriate connection.

Transport Position

1. Check machine is hitched to the tractor as described. Ensure the tractor parking brake is applied
2. Ensure rotors are not turning then transform the machine into transport position by hydraulic control
3. Lift the body clear from the ground with the tractor 3 point linkage
4. Lock in position with the transport locking pin.

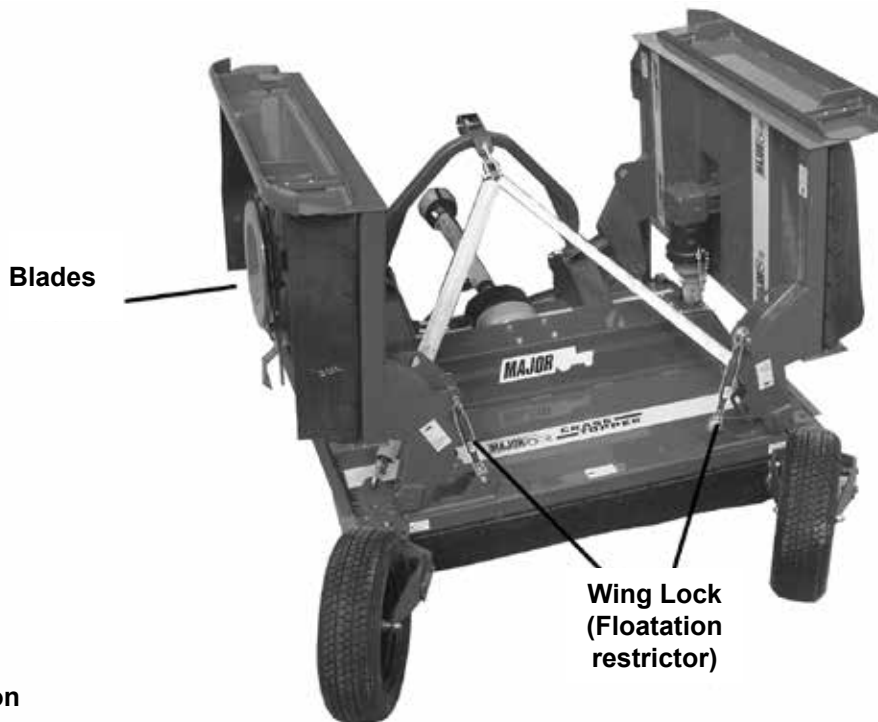

Mowing Position

1. The MAJOR Topper is designed to operate at a max 540 rpm. Always operate on level ground when connecting / disconnecting the implement. This will prevent dangerous movement.
2. Never allow anyone to stand between the tractor and the topper. Ensure the machine is hitched correctly to the tractor as previously described
3. Lower main cutting deck to the desired cutting height and lock the tractor lower link arms in position. The front mini skid acts as a bottom out skid only, with the weight of the machine held by the tractor linkage & the castor wheels.
4. Lower the wings into mowing position by hydraulic control & relocated the wing locks into flotation position.
5. Start up the tractor PTO at a low RPM.
6. Build up to operating speed, select a suitable forward gear & proceed to cut grass.



Operating the Machine/Mowing



Never place limbs under the machine while rotors are turning. Rotors can remain turning for up to 1 minute after disengaging PTO. Ensure drawbar ram is fully extended before operating PTO. This MAJOR topper is designed to operate at 540 RPM. Ensure tractor PTO output is set at 540 RPM.

1. Ensure the machine is hitched correctly to the tractor as previously described.
2. Ensure bystanders are clear from the machine & cannot be hit with debris expelled from the machine.
3. Ensure cutting decks are lowered to the ground.
4. Start up the tractor PTO at a low RPM.
5. Build up to operating speed, select a suitable forward gear & proceed to cut grass.

Wheel Assembly

The wheel assembly is not suitable for reversing. Place the pin in the appropriate location for either transport or mowing.

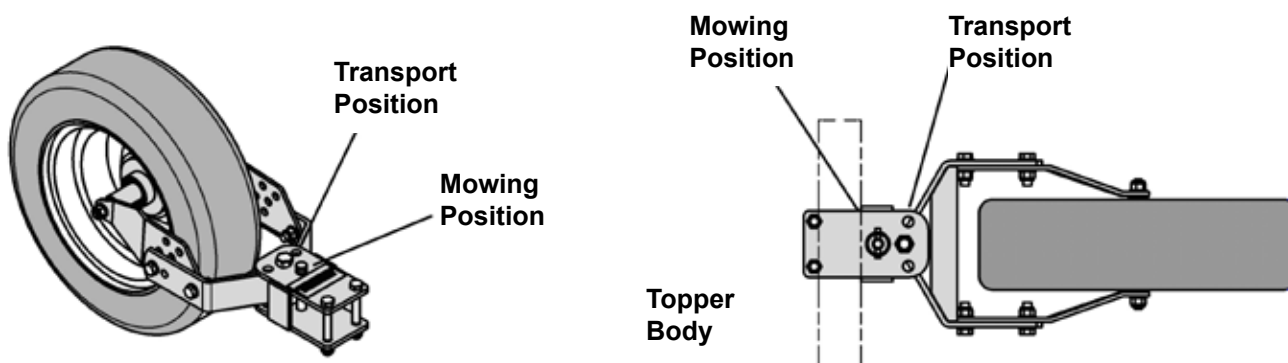

Maintenance

The machine must always be disconnected from the tractor before any cleaning, lubricating and servicing operations can be carried out. Maintenance must be carried out by qualified personnel

If emergency operations are required whilst the machine is connected to the tractor, switch off the engine, engage the parking brake and disengage the PTO.

Good, regular maintenance and correct use are if the topper is to remain safe and long lasting.

PTO Shaft Maintenance

Guard Removal and Yoke End Greasing

1. Prise back locking tabs
2. Pull back PTO Guard
3. Grease points as shown
4. Push Guard into position
5. Click into place
6. Tie check chain

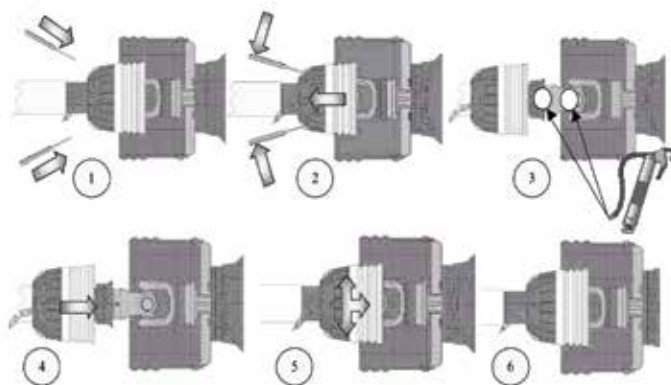

PTO Guard Greasing Intervals

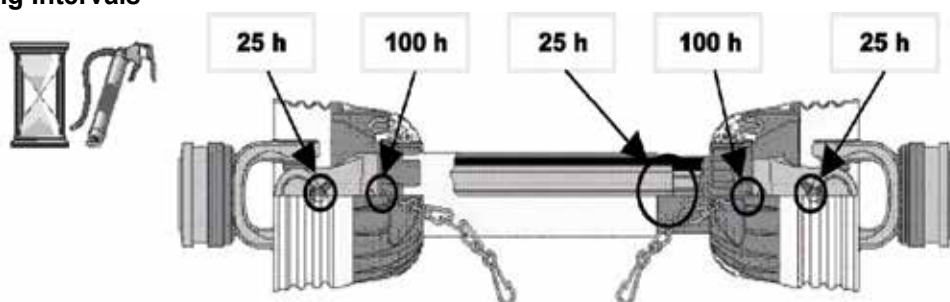

Shearbolt Replacement

1. Slide yoke shield back.
2. Drive out sheared bolt with hammer and punch.
3. Align holes and install new shear bolt. (Use only genuine MAJOR replacement shear bolts. M8X50 BZP -8.8)
4. Slide yoke shield securely in place

Fit PTO shaft with the shearbolt end connected to the Topper as directed on the PTO guarding.

All nuts and bolts in the transmission including Rubber couplings, Star Drives, PTO Shafts and Gearboxes should be checked for tightened after mowing at the following intervals.

- 1st 50 Acres
- 1st 100 Acres
- 1st 250 Acres
- And every 250 acres thereafter.

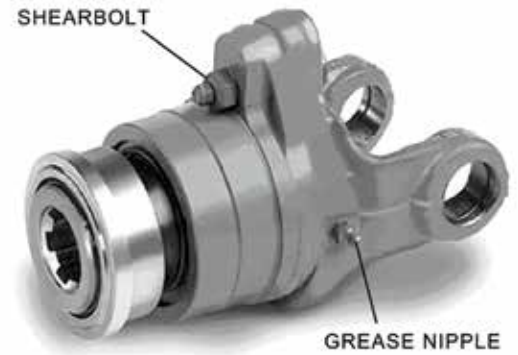

Blade Rotation

NOTE: ENSURE BLADE ROTATION AND TIMING IS CORRECT AFTER SERVICING TRANSMISSION.

Blades must always be timed at 90o to each other. Failure to do so can cause the blades to foul & in turn may damage the transmission.

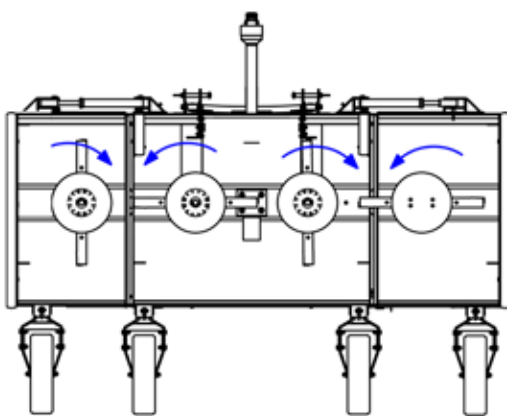

BLADE ROTATION
VIEWED FROM UNDERSIDE

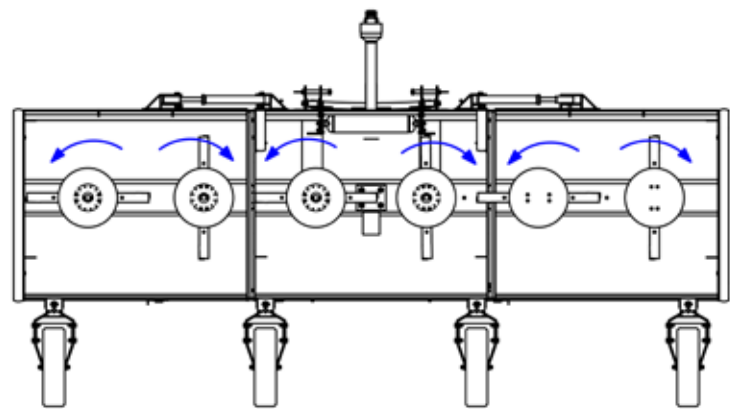

BLADE ROTATION
VIEWED FROM UNDERSIDE

Maintenance Schedule

	INITIALLY	8 HOURS
PTO Shaft Yoke Ends (8)	●	●
Wing pivot (4)	●	●
Castor wheel pivots	●	●

Trouble Shooting

Fault	Cause	Remedy	
Leaves a streak of uncut or partially cut grass	Blades dull or bent	Replace blades	
	Carrier RPM too low	Use correct PTO speed	
	Field conditions are so wet that the tractor tyre is pushing grass into mud	Too wet to mow. Stop operation and wait until it is drier	
	Ground speed too fast	Reduce ground speed by shifting to a lower gear	
	Possible build-up materials under mower	Clean mower	
	Blades mounted incorrectly (cutting edge against direction rotation)	Change blades so that cutting edge is facing correct rotation.	
Material discharges from mower unevenly; bunches of material along with swath	Material too high and too much material	Reduce ground speed but maintain 540rpm at tractor PTO or make two passes over material. Raise mower for the first pass and lower to desired height for the second and cut a 90 degree angle to first pass	
Gearbox overheating	Low on lubricant	Fill to proper level	
	Improper type lubricant	Replace with proper lubricant	
	Excessive grass / debris build-up around gearbox	Remove grass, etc from machine	
Blade is scalping ground	Mower too low	Raise mower-reset wheels	
	Field is ridged	Cut field at a different angle	
	Field is too wet	Stop and wait until it is dried	
Mower will not cut.	Shear bolt sheared	Install new shear bolt	
Blades wear too fast	Cutting in sandy conditions	Increase cutting height	
	Cutting in rocky conditions	Increase cutting height	
	Blades hitting ground	Increase cutting height	
Mower seems to require excessive power	Advancing into grass too rapidly	Reduce forward travel speed	
	Hitting ground	Raise mower and reset wheels	
	Worn or dull blades	Sharpen or replace blades	
	Tractor not large enough	Use larger horsepower tractor	
Excessive vibration	Check gearbox bolts	Tighten if loose	
	Check for loose nuts on blades	Tighten if loose	
	Blade broken	Replace blades, in set	
	New blade or bolts matched with worn blade or bolts	Replace blades or bolts in sets	
	Drivelines not phased correctly. Implement and tractor yokes must be in line	Phase the driveline. Replace if necessary	
Noisy machine	Worn bearing	Replace bearings	
	Low oil in gearbox	Check level and add oil	
	Loose Parts	Check all bolts are fully tightened	
	Wrong PTO rpm rate	Check PTO rate & adjust as necessary	
	Rotors bent / broken	Replace bent or missing blades	
	Bent PTO shaft	Check PTO shafts are aligned correctly	
		Check output shaft on gearboxes are not bent	
Check driveline between gearboxes is aligned.			
Gearbox leaking	Damaged oil seal	Replace seal	
	Bent shaft	Replace oil seal and shaft	
	Shaft rough in oil seal area	Replace or repair shaft	
	Oil seal installed incorrectly	Replace seal	
	Oil seal not sealing in the housing	Replace seal or use a sealant on outside diameter of seal	
	Oil level too high	Drain oil to proper level	
	Hole in gearbox	Replace the gearbox	
	Gasket damaged	Replace gasket	
	Bolts loose	Tighten bolts	

Spare Parts - Flex Wing

Flex Wing Topper Overview

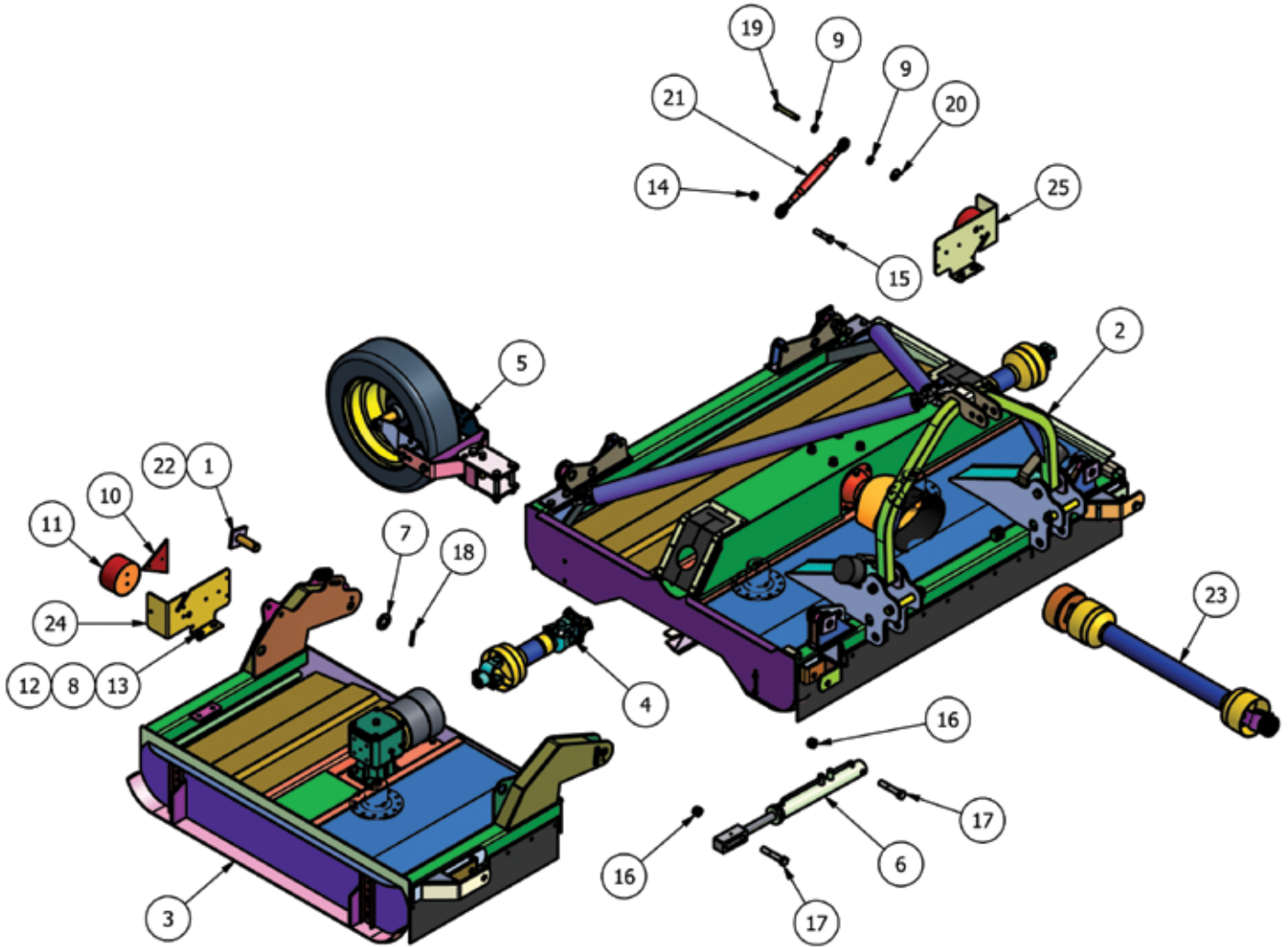

Item	Part No	Description	Qty
1	12W-PIN07 (12GM-P1)	PIVOT PIN	4
2	12W3-BGA	12W3 BODY ASSY	1
3	12W3-WGA	12W3 WING (RH)	1
4	T50-12W	12000 WING PTO SHAFT	2
5	TWA-002	TOPPER CAR WHEEL ASSY	2
6	17GM-WR4	WING LIFT RAM	2
7	FW114	DIA 1 1/4" FLAT WASHER	4
8	FWM12	M12 FLAT WASHER	4
9	FWM16	M16 FLAT WASHER	4
10	LC2700	TRIANGLE REFLECTOR	2
11	LC360	LAMP	2
12	M12	M12 NYLOC NUT	4
13	M12x30SZP	M12x30 SET BOLT	4

Item	Part No	Description	Qty
14	M16	M16 NYLOC NUT	2
15	M16x75BZP	M16x75 BOLT	2
16	M20	M20 NYLOC NUT	4
17	M20x110BZP	M20x110 BOLT	4
18	1234	ROLL PIN DIA 10x60	4
19	15501	CAT 0 PIN DIA 16x97mm	2
20	37	LINCH PIN DIA 6	2
21	4419	CAT 0 TOP LINK	2
22	820	GREASE NIPPLE M6 STR	4
23	V600910ENC12RW6	V60 FIXED SLIP CLUTCH	1
24	TA LGPLITL	LGP LIGHT BRACKET (LH)	1
25	TA LGPLITR	LGP LIGHT BRACKET (RH)	1

12000FW-HD and 18000FW-HD body assembly

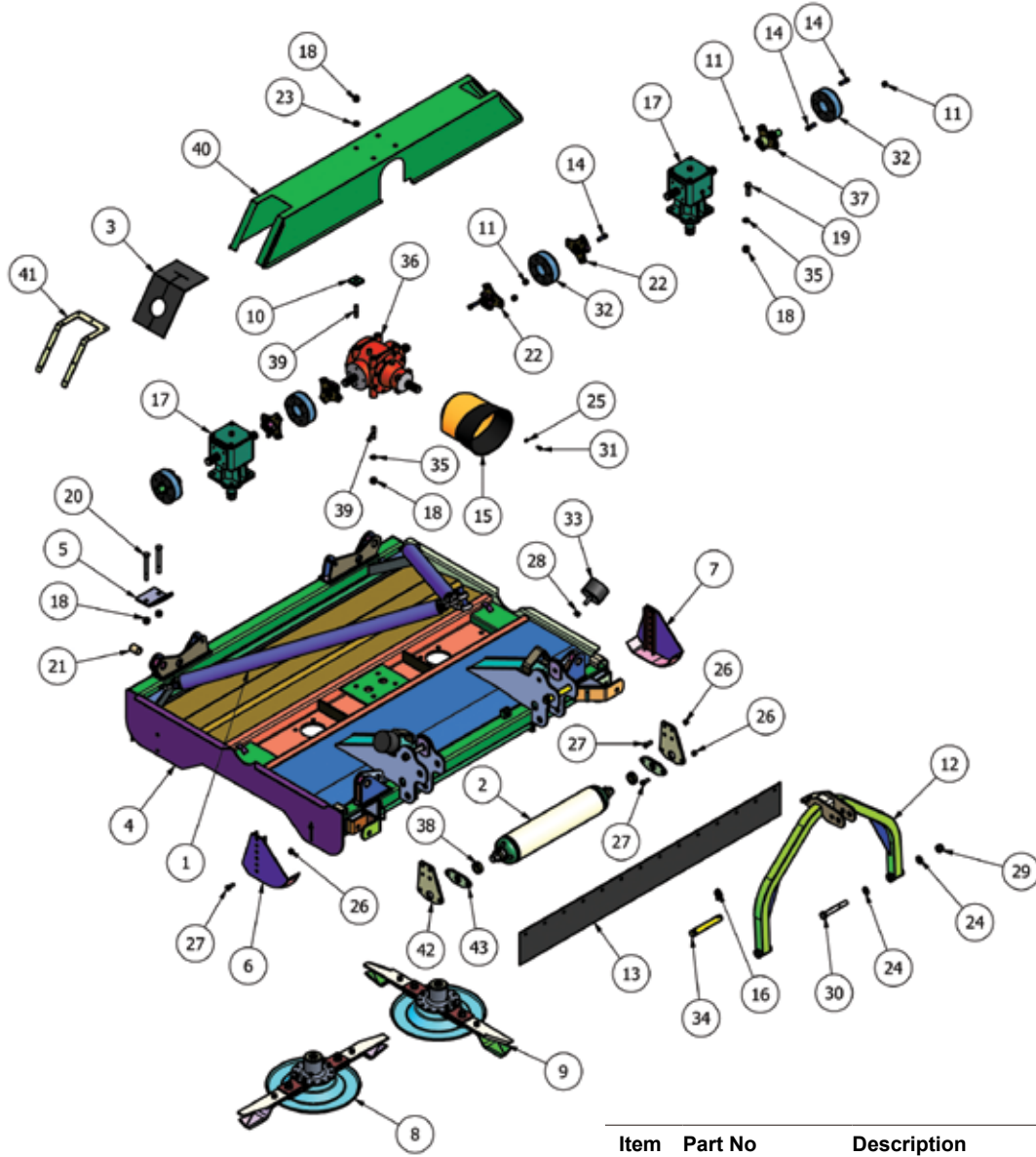

Item	Part No	Description	Qty
1	123PL-STRAP01	12000 CHAIN SLING	1
2	12GMROLW	12000 WING ROLLER	1
3	12GMTCC1	G/BOX RUBBER COVER END	2
4	12W3-B001	1200/1800 3PL BODY	1
5	12W3-B020	STRAP MOUNT	2
6	12W3-SKD01	MINI SKID (RH)	1
7	12W3-SKD02	MINI SKID (LH)	1
8	951V2-D-BL	951 BLADE (Anti_Clk)	1
9	951V2-D-BR	951 BLADE (Clk)	1
10	GM12-A	GUARD MOUNT BUFFER	4
11	1/2F	1/2" FINE NYLOC NUT	24
12	123RMA01	HEAVY A-FRAME	1
13	12W3-G002	SKIRT (BODY)	2
14	12x112FSKS	1/2"x1 1/2" FINE SOCKET HEAD 12.9	24
15	190.000.545	PTO GUARD (EXTENDED OVAL)	1
16	3546	LINCH PIN DIA 9.5	2
17	MJ40T21	6/21 SPLINE "T" BOX RATIO 1.47	2
18	5/8F	5/8" FINE NYLOC NUT	20
19	58x2FBZP	5/8"x2" FINE BOLT	8
20	58x512FBZP	5/8"x5 1/2" FINE BOLT	4
21	8SM14	DIA 1 1/4" BUSHx1 3/4"	4
22	DRV-6S-52DC	6 SPLINE 52mm DRIVE	4
23	FWM16	M16 FLAT WASHER	4
24	FWM20	M20 FLAT WASHER	4
25	FWM8	M8 FLAT WASHER	4
26	M12	M12 NYLOC NUT	16
27	M12x35BZP	M12x35 BOLT	16
28	M16	M16 NYLOC NUT	2
29	M20	M20 NYLOC NUT	2
30	M20x150BZP	M20x150 BOLT	2
31	M8x16SZP	M8x16 SET BOLT	4
32	MJRC-113	113 PCD RUBBER COUPLING	4
33	MOT75	DIA 105x75 BUFFER	2
34	112	CAT 2 PIN DIA 28.5x159mm	2
35	SW58	5/8" SPRING WASHER	12
36	T292B	6 SPLINE "T" BOX RATIO 1.86	1
37	12EW45-2	21 SPLINE STAR DRIVE	2
38	RM-RSN3	SHAFT COLLAR DIA 35	2
39	T292A-S1	T292 G/BOX STUD	8
40	12GMTCC-2	12000 BODY COVER	1
41	12TC-E	G/BOX COVER END	2
42	12W3-B025	ROLLER MOUNT	2
43	RM-RSN2	ROLLER MOUNT	2

12000FW-HD wing

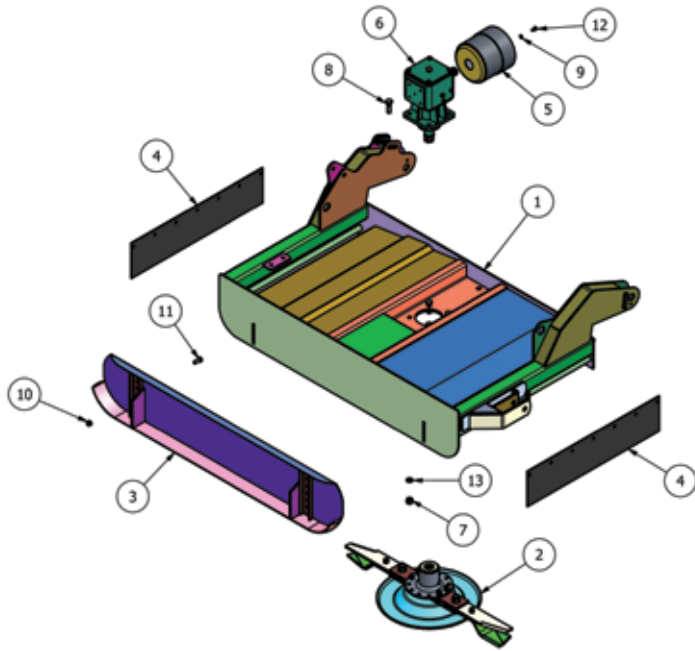

Item	Part No	Description	Qty
1	12W3-W001	12W3 WING	1
2	951V2-D-BR	951 BLADE (Clk)	1
3	SLH16AS	SKID (OFFSET)	1
4	12W3-G003	SKIRT (WING)	2
5	190660-1	GUARD (COVER 660/BASE 661)	1
6	MJ40L	6 SPLINE "L" BOX RATIO 1.47	1
7	5/8F	5/8" FINE NYLOC NUT	4
8	58x2FBZP	5/8"x2" FINE BOLT	4
9	FWM8	M8 FLAT WASHER	4
10	M12	M12 NYLOC NUT	4
11	M12x30SZP	M12x30 SET BOLT	4
12	M8x16SZP	M8x16 SET BOLT	4
13	SW58	5/8" SPRING WASHER	4

18000FW-HD wing

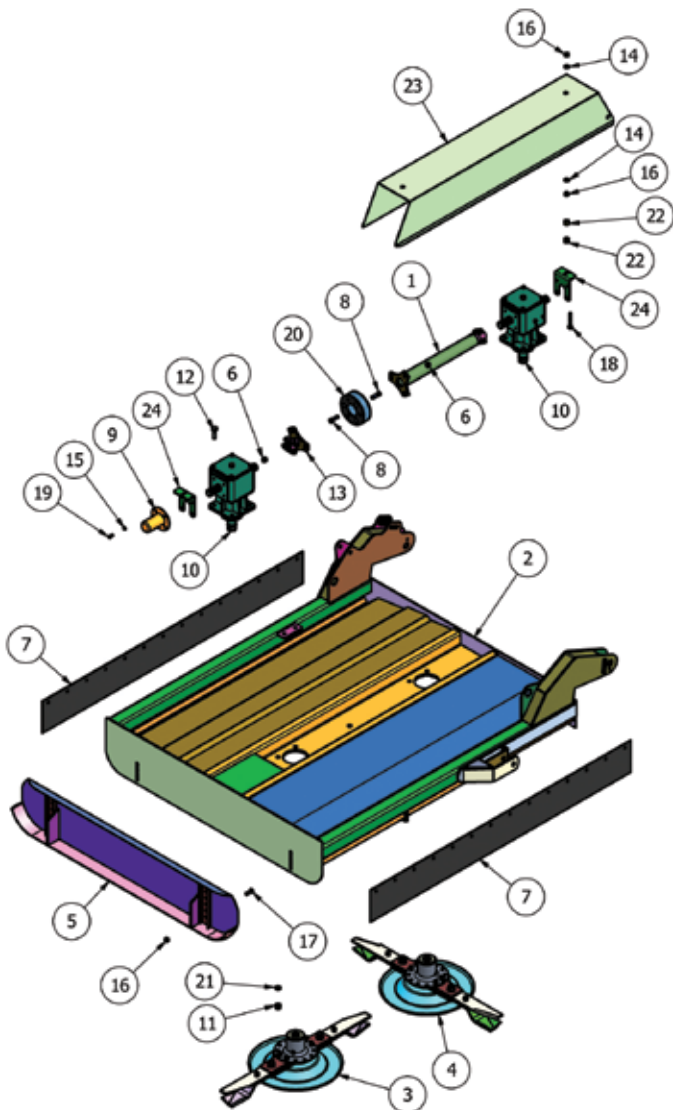

Item	Part No	Description	Qty
1	18GM-WDT	18000 DRIVE TUBE	1
2	18W3-W001	18W3 WING	1
3	951V2-D-BL	951 BLADE (Anti_Clk)	1
4	951V2-D-BR	951 BLADE (Clk)	1
5	SLH16AS	SKID (OFFSET)	1
6	1/2F	1/2" FINE NYLOC NUT	6
7	12W3-G002	SKIRT (BODY)	2
8	12x112FSKS	1/2"x1 1/2" FINE SOCKET HEAD 12.9	6
9	190000592	PTO HAT	1
10	MJ40T	6 SPLINE "T" BOX RATIO 1.47	2
11	5/8F	5/8" FINE NYLOC NUT	8
12	58x2FBZP	5/8"x2" FINE BOLT	8
13	8SM18	6 SPLINE STAR DRIVE	1
14	FWM12	M12 FLAT WASHER	4
15	FWM8	M8 FLAT WASHER	4
16	M12	M12 NYLOC NUT	8
17	M12x30SZP	M12x30 SET BOLT	4
18	M12x80BZP	M12x80 BOLT	2
19	M8x16SZP	M8x16 SET BOLT	6
20	MJRC-113	113 PCD RUBBER COUPLING	1
21	SW58	5/8" SPRING WASHER	8
22	12T-BBS	BLADE BACK SPACER	4
23	18GM-WTC2	18000 WING COVER	1
24	9TGT-CB	GEARBOX COVER BRKT	2

Castor wheel

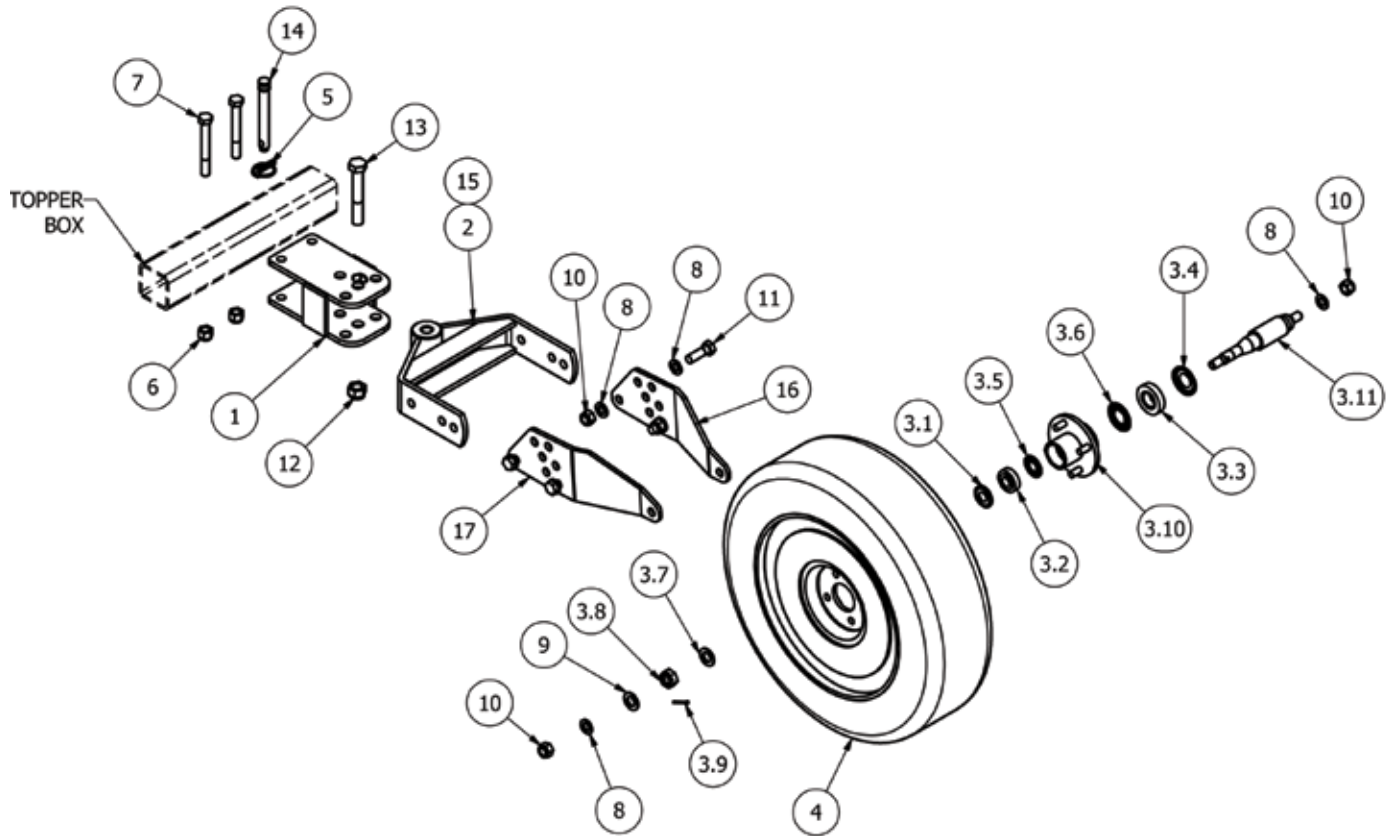

Item	Part No	Description	Qty
1	TWA-020	PIVOT MOUNT	1
2	TWA-030	PIVOT ARM	1
3.1	30204AV	NILOS RING 47x20	1
3.2	30204CPT	TAPER BRG 47x20x15.25	1
3.3	30206CPT	TAPER BRG 62x30x17.25	1
3.4	30206AV	NILOS RING 62x30	1
3.5	915N30204	SHEILD 47x20	1
3.6	915N30206	SHEILD 62x30	1
3.7	FWM20	M20 FLAT WASHER	1
3.8	M20FCASLET	CASTLE NUT (THIN)	1
3.9	1500	SPLIT PIN 1/8"x1 1/2"	1
3.10	TWA-052	TOPPER 4 STUD AXLE HUB	1
3.11	TWA-056	HUB SHAFT FOR 17570R14	1
4	175X14W	175 X 14" WHEELS	1

Item	Part No	Description	Qty
5	3546	LINCH PIN DIA 9.5	1
6	5/8F	5/8" FINE NYLOC NUT	2
7	58x5FBZP	5/8"x5" FINE BOLT	2
8	FWM16	M16 FLAT WASHER	10
9	FWM20	M20 FLAT WASHER	1
10	M16	M16 NYLOC NUT	6
11	M16x50BZP	M16x50 BOLT	4
12	M20	M20 NYLOC NUT	1
13	M20x130BZP	M20x130 BOLT	1
14	77	CAT 1 PIN DIA 19x127mm	1
15	851	GREASE NIPPLE M8x1.25 STR	1
16	TWA-045	AXLE PLATE (CAR)	1
17	TWA-045H	AXLE PLATE (CAR)	1

Blade Systems

PRO-CUT BLADE SYSTEMS - 951V2-D-BL on all Flex Wing models from January 2011

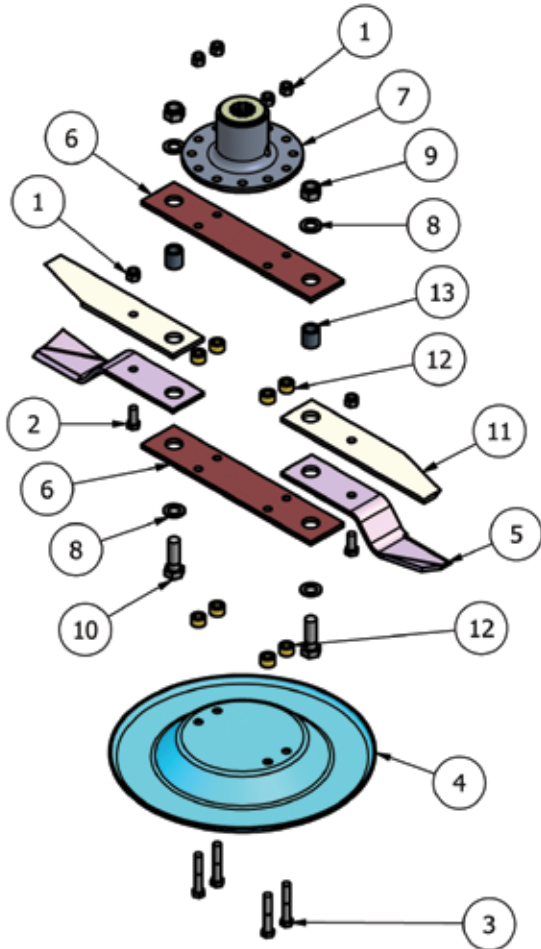

Item	Part No	Description	Qty
1	1/2F	1/2" FINE NYLOC NUT	6
2	12x114FBZP	1/2"x1 1/4" FINE BOLT	2
3	12x3FBZP	1/2"x3" FINE BOLT	4
4	9GT-USS	UNDER SOLE SKID	1
5	9GTB/A	SWING BLADE (Anti-Cik)	2
6	BLDB-335	BLADE BACK (335 CTR)	2
7	DF-BMP	J205 G/BOX BLADE MOUNT	1
8	FWM20	M20 FLAT WASHER	4
9	M20	M20 NYLOC NUT	2
10	M20x60BZP	M20x60 BOLT	2
11	NTSB12C	OVERLAP BLADE	2
12	12T-BBS	BLADE BACK SPACER	8
13	12T-LBB	OVERLAP BLADE BUSH	2

MACHINE	QTY
12000FW-HD	2 clockwise 2 anti clockwise
18000FW-HD	3 clockwise, 3 anti clockwise)

PRO-CUT BLADE SYSTEMS - 951V2-D-BR on all Flex Wing models from January 2011

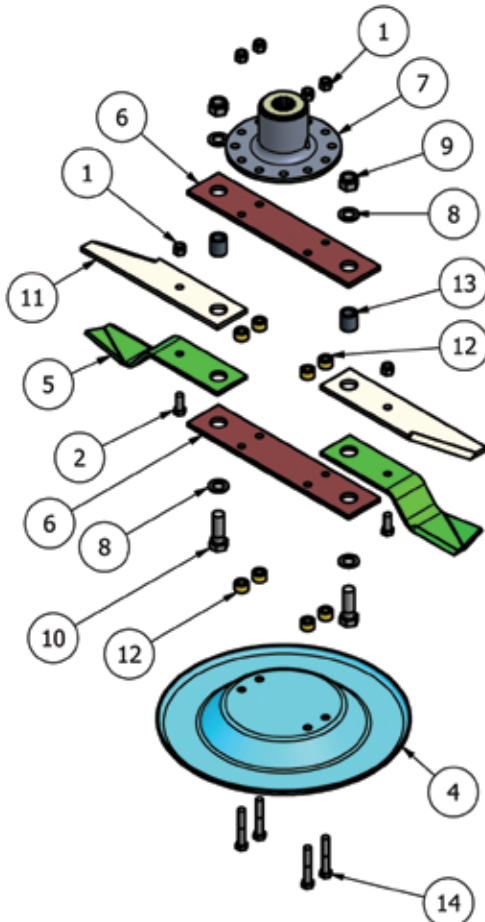

Item	Part No	Description	Qty
1	1/2F	1/2" FINE NYLOC NUT	6
2	12x114FBZP	1/2"x1 1/4" FINE BOLT	2
4	9GT-USS	UNDER SOLE SKID	1
5	9GTB/C	SWING BLADE (Cik)	2
6	BLDB-335	BLADE BACK (335 CTR)	2
7	DF-BMP	J205 G/BOX BLADE MOUNT	1
8	FWM20	M20 FLAT WASHER	4
9	M20	M20 NYLOC NUT	2
10	M20x60BZP	M20x60 BOLT	2
11	NTSB12C	OVERLAP BLADE	2
12	12T-BBS	BLADE BACK SPACER	8
13	12T-LBB	OVERLAP BLADE BUSH	2
14	12x3FBZP	1/2"x3" FINE BOLT	4

MACHINE	QTY
12000FW-HD	2 clockwise 2 anti clockwise
18000FW-HD	3 clockwise, 3 anti clockwise)

PRO-CUT BLADE SYSTEMS - on 12ft Flex Wing (12000FW-HD) and 18ft Flex Wing (18000FW-HD) Models from April 2009 - Dec 2010

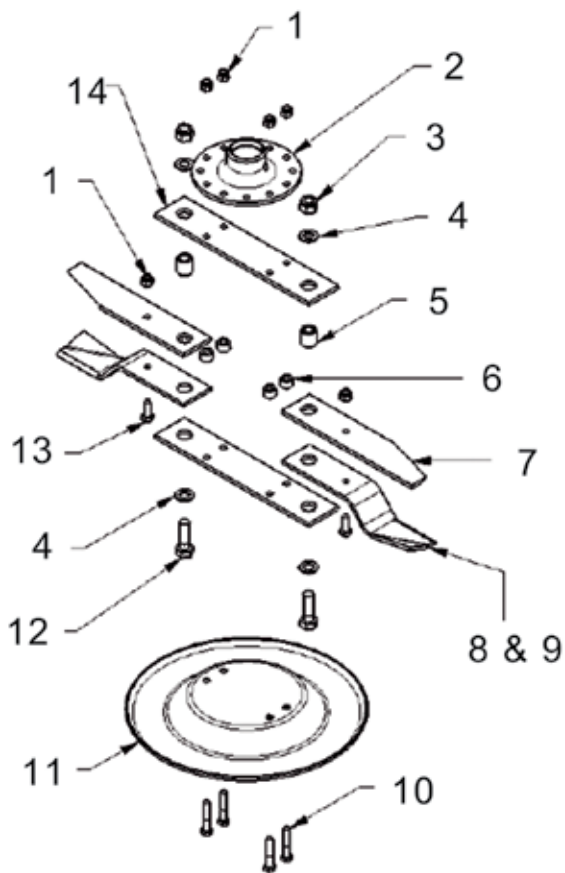

Item	Part No	Description	Qty
1	1/2F	1/2" Nyloc Nut	6
2	DF-BMP	BLADE MOUNT	1
3	M20	M20 NYLOC NUT	2
4	FWM20	M20 FLAT WASHER	4
5	12T-LBB	Overlap Blade Bushing	2
6	12T-BBS	BLADE BACK SPACER	4
7	NTSB12C	Overlap Blade	2
8	9GTB/A	Blade anti clockwise	2
9	9GTB/C	Blade clockwise	2
10	12X212FBZP	1/2"x2 1/2" FINE BOLT	4
11	9GT-USS	Under sole skid	
12	M20X60BZP	M20x60 BOLT	2
13	12x114FBZP	1/2"x1 1/4" FINE BOLT	2
14	BLDB-335	BLADE BACK	2

MACHINE	QTY
12000FW-HD	2 clockwise 2 anti clockwise
18000FW-HD	3 clockwise, 3 anti clockwise)

OLDER BLADE SYSTEMS - on all on all 12ft Flex Wing (12000FW-HD) and 18ft Flex Wing (18000FW-HD) Models prior to April 2009

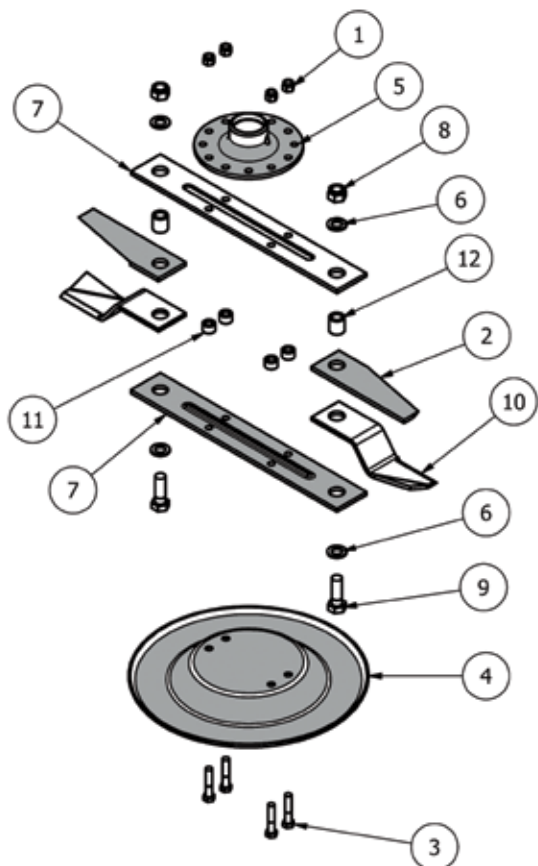

Item	Part No	Description	Qty
1	1/2F	1/2" Nyloc Nut	12
2	12T-OLB	Overlap Blade	
3	12X212FBZP	1/2"x2 1/2" FINE BOLT	
4	9GT-USS	Under sole skid	
5	DF-BMP	BLADE MOUNT	
6	FWM20	M20 Flat Washer	
7	GM26	BLADE BACK	2
8	M20	M20 NYLOC NUT	
9	M20X60BZP	M20x60 BOLT	
10	NTSB10A	SWING BLADE (Anti-Clk)	
10	8SM9/1	SWING BLADE (Clk)	
11	12T-BBS	BLADE BACK SPACER	
12	12T-LBB	Overlap Blade Bushing	

Gearboxes

Machine	Gearboxes	
12000FW-HD and 18000FW-HD Flex Wing - Body	MJ40T21	T292B
12000FW-HD Flex Wing - Wing gearbox	MJ40L	
18000FW-HD Flex Wing - Wing gearbox	MJ40T	

MJ40T21 Gearbox "T" Box Ratio 1.47 (347.802) Gearbox Breakdown

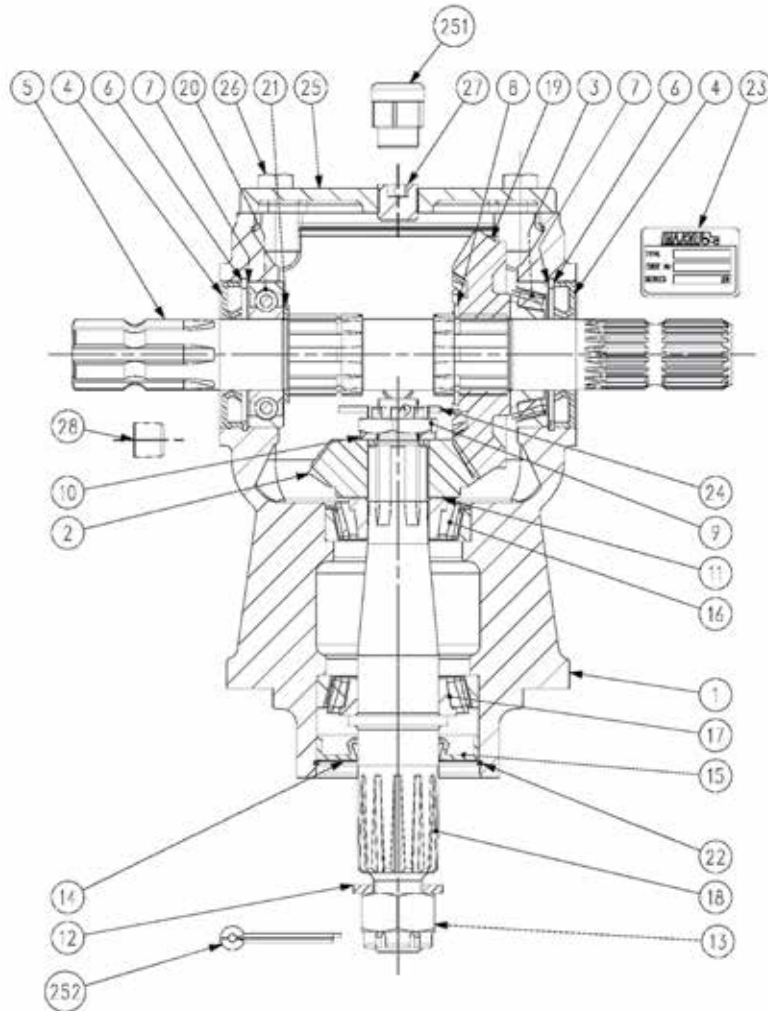

Item	Part No	Description	Qty	Item	Part No	Description	Qty
1	0.347.0300.00	Casting and Machining	1	16	8.0.9.01049	Roller Bearing 30306 (30x72x20.75)	1
2	U0.040.5004.00	Gear Pinion Z15 M5.5	1	17	8.0.9.00024	Roller Bearing 30208 (40x80x19.75)	1
3	8.0.9.00026	Roller Bearing 30207 (35x72x18.25)	1	18	U0.040.3006.01	Output Shaft ASA D.P. 8/16 Z12	1
4	8.7.3.00055	Oil Seal (35x72x10)	2	19	U0.040.6004.00	Gear Crown Z22 M5.5	1
5	0.347.3001.00	Through Shaft 1"3/8 Z6 -1"3/8 Z21	1	20	8.0.1.00870	Ball Bearing 6207 (35x72x17)	1
6	8.5.2.00131	Snap Ring (72x75x2.5 , For Shafts)	2	21	0.259.7527.00	Shim (35.3x48x2.5)	1
7	0.248.7500.00	Shim Kit (60.3x71.7)	2	22	8.5.3.00955	Snap Ring SB 81 (81x82.8x2)	1
8	8.5.1.00680	Snap Ring (40x37.5x2.5)	1	23	0.205.7100.00	"Major" Name Plate	1
9	0.289.7102.02	Castle Nut (M20x1)	1	24	8.4.7.00823	Cotter Pin (4x40)	1
10	8.3.2.00531	Flat Washer (21x37x3)	1	25	0.347.1300.00	Top cover	1
11	0.102.7500.00	Shim Kit (30.3x44)	1	26	8.1.1.00061	Bolt M10x25 HHB (8.8)	4
12	LF135-2	Flat Washer (25x44x4)	1	27	8.6.6.00088	1/2" Gas Solid Plug	1
13	LF135-1	Castle Nut (M24x2)	1	28	8.6.6.00201	3/8" Gas Oil Level Plug	1
14	1.135.7100.00	Protective Flat Washer (40.4x79.9x1)	1	251	8.6.7.00269	1/2" Gas Oil Breather Plug	1
15	8.7.1.00748	Dust Lip (40x80x12)	1	252	8.4.7.00516	Cotter Pin (5x50)	1

T292B "T" Box Ratio 1:1 (292.006) Gearbox Breakdown

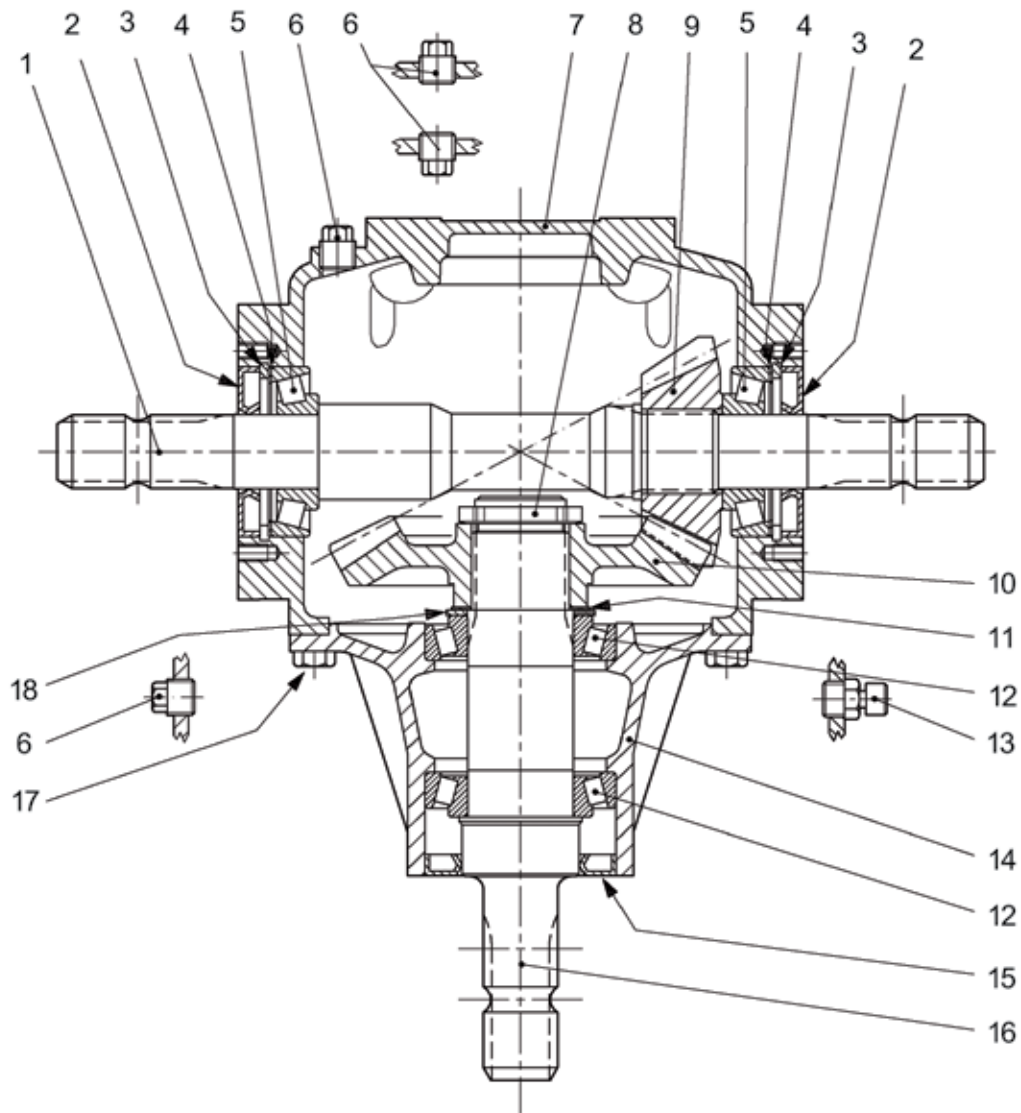

Item	Part No	Description	Qty	Item	Part No	Description	Qty
1	LF135/17H	Crown Gear 23T HS box	1	14	M10x20SZP	Bolt	1
1	LF135/17	Crown Gear 22T Std box	1	15	LF135/6	Snap Ring	1
2	LF205/12	Gearbox Casing	1	16	LF135/3	Snap Ring	1
3	LF135/18	Input Shaft	1	17	85200648	Circlip	1
4	LF135/11	Pinion Shaft	1	18	LF135/13	Plug	2
5	LF135/10	Spacer	1	19	40X80X12V	Double Lip Seal	1
6	52x7	Oil Cap (Cover)	1	20	T4A/1 (8.7.3.00055)	Double Lip Seal	1
7	LF135/4	Protective Washer	1	21	LF135/26 (LF205EP)	Cover	1
8	LF135/21	Bearing 6007 (35x62x14)	1	22	LF135/8 (02447500)	Shim	1
9	LF135/15	Bearing 6207	1	23	LF135/3 (02677500)	Snap Ring	1
10	LF135/9	Bearing 6208	2	24	0.6.775.000	Shim	1
11	LF135/1	Castle Nut	1	25	N/A	Name Plate	1
12	LF135/2	Washer	1	26	0.248.7500.00	Shim	1
13	LF135/19	Key	1	27	85200131	Circlip	1

MJ40L "L" Box Ratio 1.47 (347.800) Gearbox Breakdown

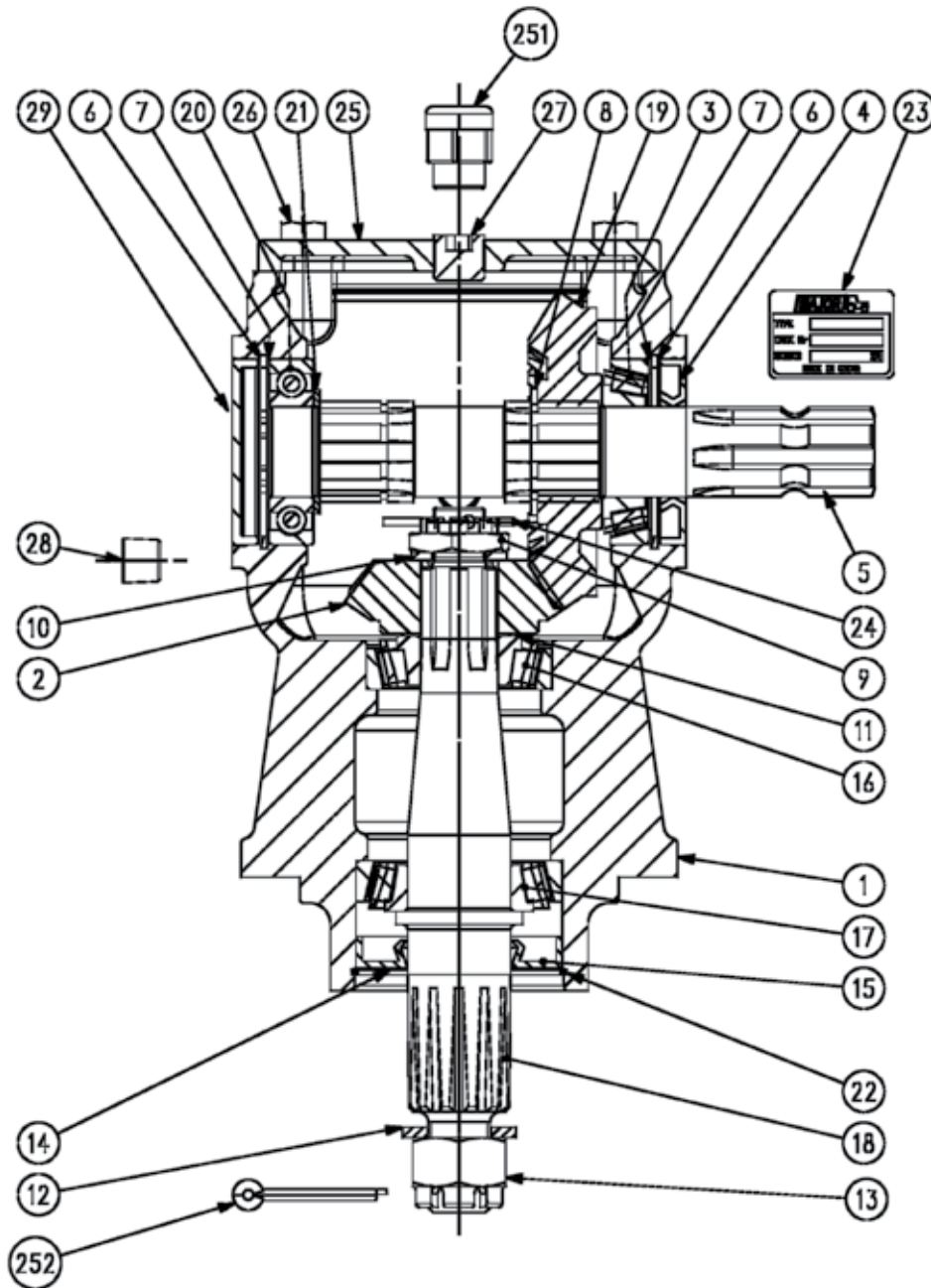

Item	Part No	Description	Qty
1	0.347.0300.00	Casting and Machining	1
2	UO.040.5004.00	Gear Pinion Z15 M5.5	1
3	8.09.00026	Roller Bearing 30207 (35x72x18.25)	1
4	8.7.3.00055	Oil Seal (35x72x10)	1
5	0.347.3002.00	Through Shaft 1 3/8 Z6	1
6	8.5.2.00131	Snap Ring (72x75x2.5 , For Holes)	2
7	0.248.7500.00	Shim Kit (60.3x71.7)	2
8	8.5.1.00680	Snap Ring (40x37.5x2.5 , For Shafts)	1
9	0.289.7102.02	Castle Nut (M20X1)	1
10	8.3.2.00531	Flat Washer (21x37x3)	1
11	0.102.7500.00	Shim Kit (30.3x44)	1
12	LF135-2	Flat Washer (25x44x4)	1
13	LF135-1	Castle Nut (M24x2)	1
14	1.135.7100.00	Protective Flat Washer (40.4x79.9x1)	1
15	8.7.1.00748	Dust Lip (40x80x12)	1
16	8.0.9.01049	Roller Bearing 30306 (30x72x20.75)	1

Item	Part No	Description	Qty
17	8.0.9.00024	Roller Bearing 30208 (40x80x19.75)	1
18	UO.040.3006.01	Output Shaft ASA D.P. 8/16 Z12	1
19	UO.040.6004.00	Gear Crown Z22 M5.5	1
20	8.0.1.00870	Ball Bearing 6207 (35x72x17)	1
21	0.259.7525.00	Shim (35.3x48x2.5)	1
22	8.5.3.00955	Snap Ring SB 81 (81x82.8x2)	1
23	0.205.7100.00	"Major" Name Plate	1
24	8.4.7.00823	Cotter Pin (4x40)	1
25	0.347.1300.00	Top Cover	1
26	8.11.00061	Bolt M10x25 HHB (8.8)	4
27	8.6.6.00088	1/2" Gas Solid Plug	1
28	8.6.6.00201	3/8" Gas Oil Level Plug	1
29	8.7.0.00744	Oil Cap (72x10)	1
251	8.6.7.00269	1/2" Gas Oil Breather Plug	1
252	8.4.7.00516	Cotter Pin (5x50)	1

MJ40T "T" Box Ratio 1.47 (347.801) Gearbox Breakdown

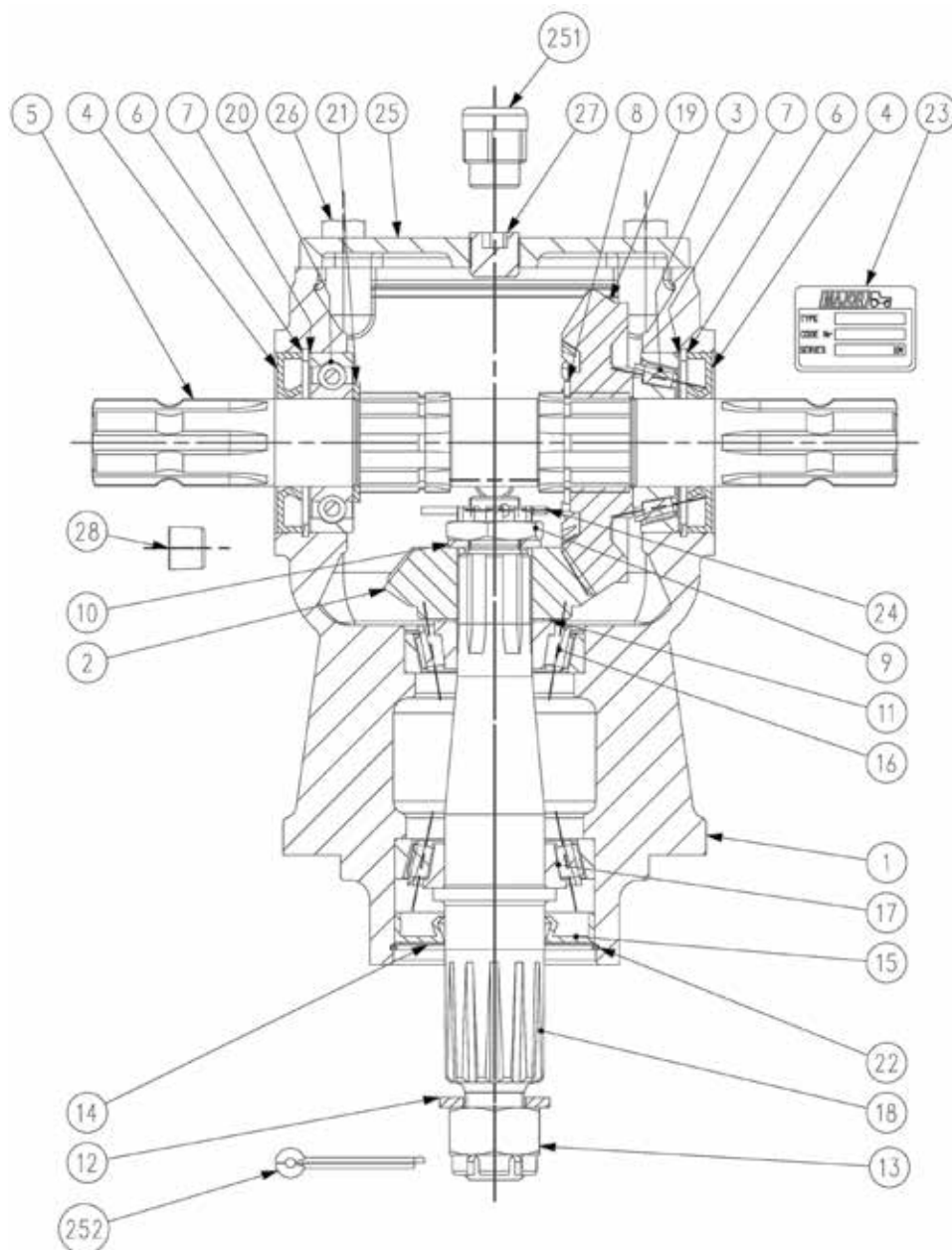

Item	Part No	Description	Qty
1	0.347.0300.00	Casting and Machining	1
2	U0.040.5004.00	Gear Pinion Z15 M5.5	1
3	8.0.9.00026	Roller Bearing 30207 (35x72x28.25)	1
4	8.7.3.00055	Oil Seal (35x72x10)	2
5	0.347.3000.00	Through Shaft 1"3/8 Z6 - 1"3/8 Z6	1
6	8.5.2.00131	Snap Ring (72x75x2.5 , For Holes)	2
7	0.248.7500.00	Shim Kit (60.3x71.7)	2
8	8.5.1.00680	Snap Ring (40x37.5x2.5 , for shafts)	1
9	0.289.7102.02	Castle Nut (M20x1)	1
10	8.3.2.00531	Flat Washer (21x37x3)	1
11	0.102.7500.00	Shim kit (30.3x44)	1
12	LF135-2	Flat Washer (25x44x4)	1
13	LF135-1	Castle Nut (M24x2)	1
14	1.135.7100.00	Protective Flat Washer (40.4x79.9x1)	1
15	8.7.1.00748	Dust Lip (40x80x12)	1

Item	Part No	Description	Qty
16	8.0.9.01049	Roller Bearing 30306 (30x72x20.65)	1
17	8.0.9.00024	Roller Bearing 30208 (40x80x19.75)	1
18	U0.040.3006.01	Output Shaft ASA D.P. 8/16 Z12	1
19	U0.040.6004.00	Gear Crown Z22 M5.5	1
20	8.0.1.00870	Ball Bearing 6207 (35x72x17)	1
21	0.259.7525.00	Shim (35.5x48x2.5)	1
22	8.5.3.00955	Snap Ring SB 81 (81x82.8x2)	1
23	0.205.7100.00	"Major" Name Plate	1
24	8.4.7.00823	Cotter Pin (4x40)	1
25	0.347.1300.00	Top Cover	1
26	8.1.1.00061	Bolt M10x25 HHB (8.8)	4
27	8.6.6.00088	1/2" Gas Solid Plug	1
28	8.6.6.00201	3/8" Gas Oil Level Plug	1
251	8.6.7.00269	1/2" Gas Oil Breather Plug	1
252	8.4.7.00516	Cotter Pin (5x50)	1

Flex Wing Hydraulics

Wing Ram 'Open' Hose Detail

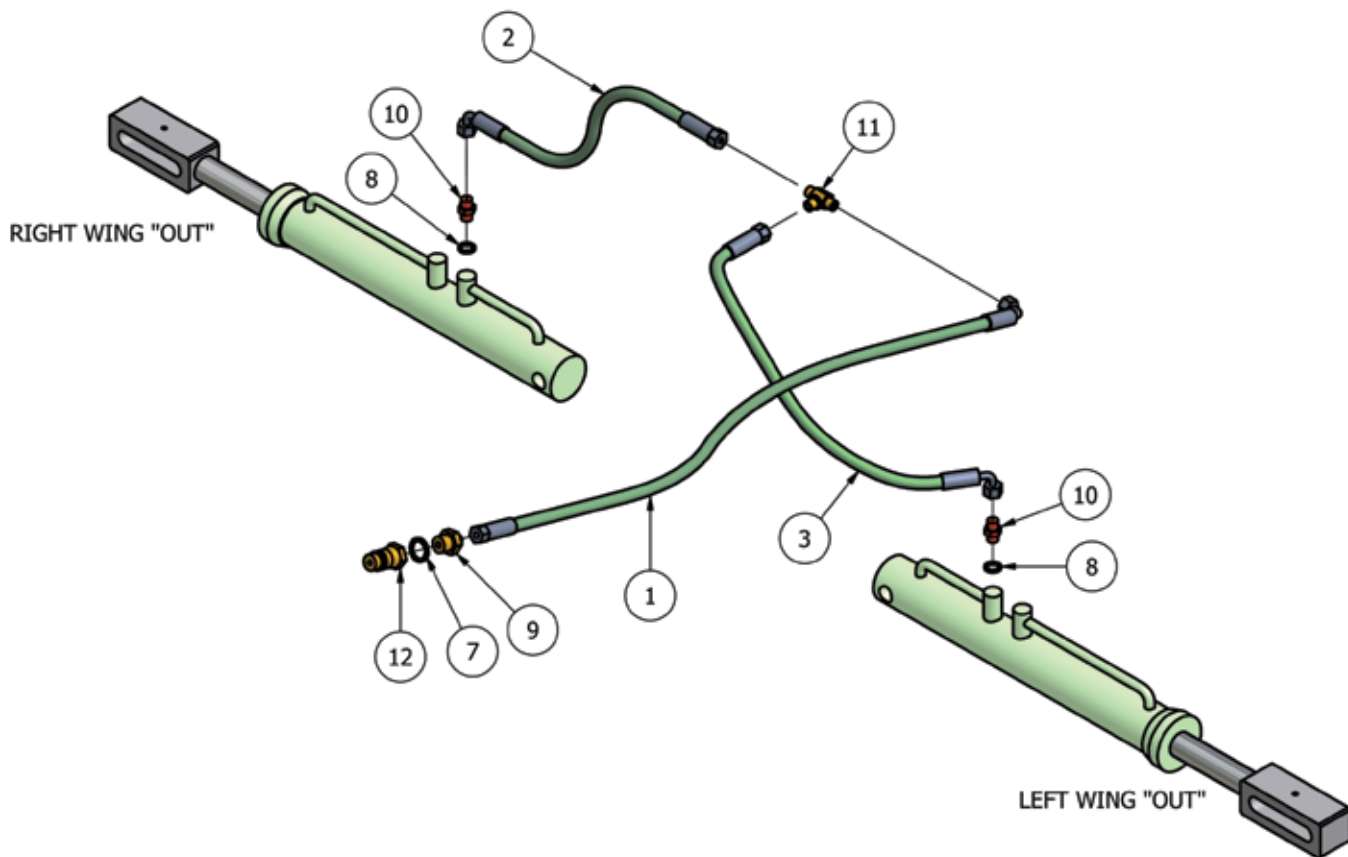

Wing Ram 'Closed' Hose Detail

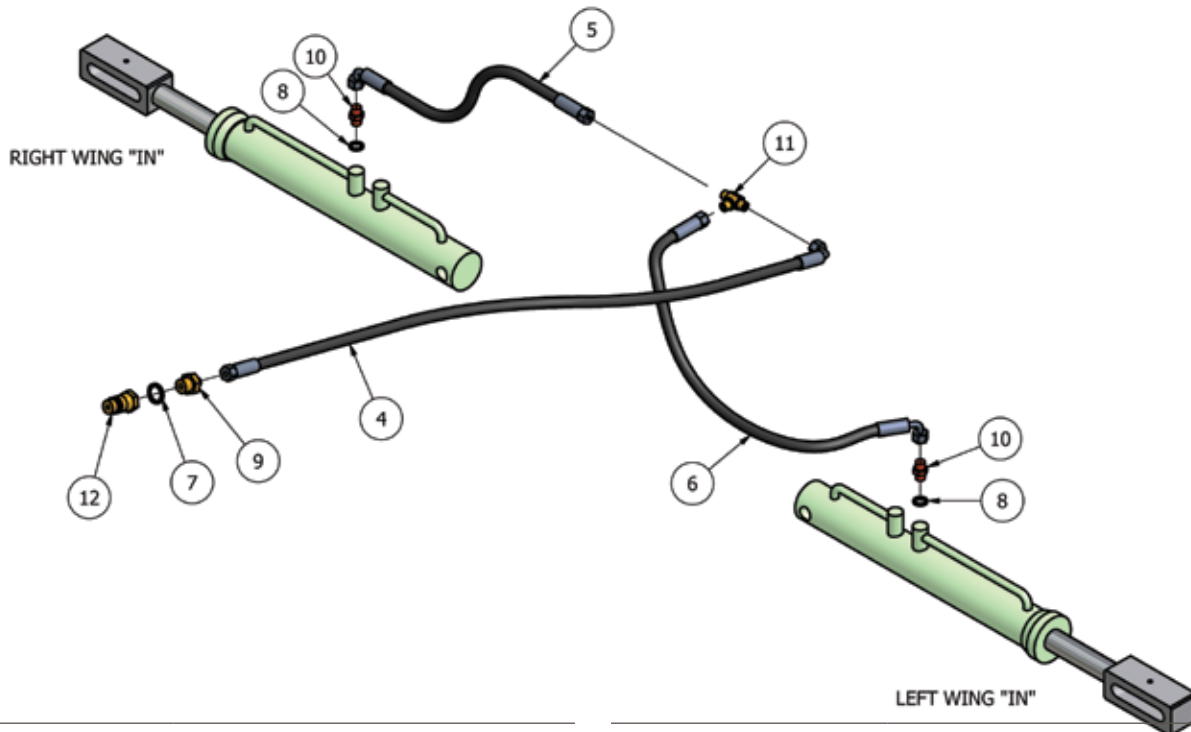

Item	Part No	Description	Qty
1	123RM-HOSE-A	1/4"x1800mm Str to Block 90	1
2	123RM-HOSE-B	1/4"x1345mm Str to Block 90	1
3	123RM-HOSE-C	1/4"x1020mm Str to Block 90	1
4	123RM-HOSE-D	1/4"x1800mm Str to Block 90	1
5	123RM-HOSE-E	1/4"x1420mm Str to Block 90	1
6	123RM-HOSE-F	1/4"x1020mm Str to Block 90	1

Item	Part No	Description	Qty
7	EDOW12	1/2" DOWTY WASHER	2
8	EDOW14	1/4" DOWTY WASHER	4
9	EMM1214	1/2-14" M/M CONNECTOR	2
10	EMM14RV	1/4" M/M RESTRICTOR (DIA 1mm)	4
11	EMMMT14	1/4" M/M/M CONNECTOR	2
12	QRM12	1/2" QUICK RELEASE MALE	2

Warranty: This machine is guaranteed for 12 months. No warranty is given where the machine is being used as a hire machine. Warranty is against faulty workmanship or parts, with the exception of components not of MAJOR'S manufacture or design, i.e. hydraulic components, universally jointed shafts, chains and tyres, etc., which are subject to the original manufacturers conditions. To register your machine for warranty, please go to the support section of our website www.major-equipment.com and enter your details.

MAJOR
WWW.MAJOR-EQUIPMENT.COM

The Grass & Slurry Machinery Specialists
Agricultural ~ Professional Groundsare ~ Industrial

Home Products About Us Gallery Dealers News **Support** Contact Us

You are in: English >> Support

Support

Product Registration

Please click here to register your machine. We are committed to providing you with excellent products and product support. Please register your machine to ensure you get the correct warranty cover and service bulletins.

Product Support

Please click here to access operator manuals.

Dealer Support

Please click here for access to our dealer support area.

- Support
- Product Registration
- Operator Manuals & Spare Parts Books
- Dealer Support
- Support Contact
- FAQ

follow us on facebook

Recent News

- ▶ 3100LGP With Raingun
- ▶ New Website Launch!
- ▶ Major Heads For Oz
- ▶ Visit Our Facebook Page
- ▶ 2012 Shows

MAJOR
WWW.MAJOR-EQUIPMENT.COM

Head Office:
Ballyhaunis, Co. Mayo
Ireland
Tel: + 353 (0) 949630572
info@major-equipment.com

UK Office:
Major Ind. Estate, Heysham
Lancs, LA3 3JJ
Tel: + 44 (0) 1524 850501
ukinfo@major-equipment.com

Nederland (& Deutschland):
Postbus 29, NL-7700 AA Dedemsvaart
Nederland
Tel: + 31 (0) 6389 19585
euinfo@major-equipment.com



HEAD OFFICE

Major Equipment Intl Ltd
Ballyhaunis, Co Mayo
Ireland
Tel: +353 (0) 9496 30572

UK OFFICE

Major Equipment Ltd
Major Ind. Estate, Heysham,
Lancs, LA3 3JJ, UK
Tel: +44 (0) 1524 850501

Netherlands & Germany OFFICE

Major Equipment Intl Ltd
Postbus 29, NL-7700 AA
Dedemsvaart, Nederland
Tel: + 31 (0) 6389 19585