



MAINTENANCE MANUAL



ADR SYSTEM GROUP

adrspare parts system

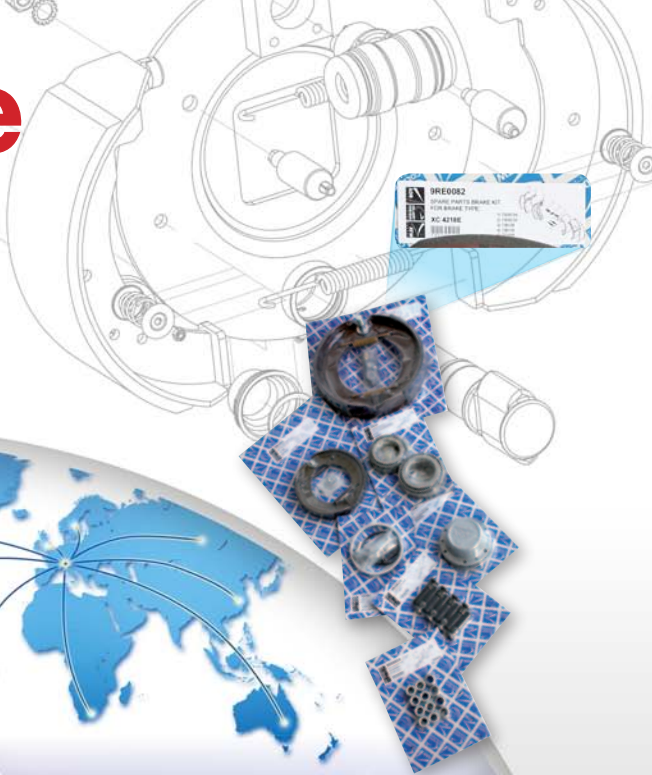

ORIGINAL K ADR
SPARES & ACCESSORIES

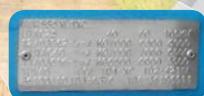

MAINTENANCE MANUAL

ADR SYSTEM GROUP



Manufacturer's official language

Version

Edition: 08/2015

Revision level: 00

Document code:



Contents

1	Important information.....	5
1.1	General information	5
1.2	Warranty conditions	5
1.3	Symbols and terms used in the manual	6
1.4	Suggestions for your safety	6
1.5	Product identification data	8
1.5.1	Axle identification plate	8
1.5.2	Suspension identification plate	8
1.5.3	Product identification plate reading	8
1.6	Summary of the main international farm vehicle tyre mounting diagrams.	9
1.6.1	Mount with centring on columns	9
1.6.2	Mount with centring on hub.....	10
2	Axles ADR - Colaert Fixed axle series/Steering axle series	A-13
2.1	ADR - Colaert maintenance work summary table	A-13
2.2	Rigid axle: Lubrication and maintenance point map	A-14
2.3	Dual Mode steering axle: Lubrication and maintenance point map.....	A-15
2.4	Standard self-steering axle: Lubrication and maintenance point map	A-16
3	BOGIE ADR - COLAERT mechanical suspensions	BM-31
3.1	BOGIE ADR - COLAERT maintenance work summary table	BM-31
3.2	Bogie Series B / C / D / E / I / K / L mechanical suspensions	BM-32
3.2.1	Lubrication and maintenance map.....	BM-32
3.3	Bogie Series A / X / Y mechanical suspensions	BY-38
3.3.1	Lubrication and maintenance map.....	BY-38
3.4	Bogie Series Z mechanical suspensions	BZ-44
3.4.1	Lubrication and maintenance map.....	BZ-44
4	Tandem and Tridem ADR - COLAERT series K mechanical suspensions	KB-51
4.1	Tandem and Tridem Series KB and series KE	KB-51
4.1.1	KB/KE series suspension maintenance work summary table	KB-51
4.1.2	Tandem and Tridem Series KB and series KE layout	KB-52
4.1.3	Lubrication and maintenance map.....	KB-52
4.2	Tandem and Tridem Series KC and series KD	KC-58
4.2.1	KC/KD series suspension maintenance work summary table	KC-58
4.2.2	Tandem and Tridem Series KC and series KD layout.....	KC-59
4.2.3	Lubrication and maintenance map.....	KC-59
4.3	Tandem and Tridem Series KW	KW-63
4.3.1	KW series suspension maintenance work summary table	KW-63
4.3.2	KW tandem and tridem layout	KW-64
4.3.3	Lubrication and maintenance map.....	KW-64
5	ADR - COLAERT HydrOK series and HydroEVO series oil hydraulic suspensions	HK-71
5.1	HydrOK series suspension maintenance work summary table	HK-71
5.2	Oil hydraulic suspensions with KFRAME ADR - COLAERT HydrOK series rods	HK-72
5.2.1	Oil hydraulic suspension layout with KFRAME compensation rods	HK-72
5.2.2	Lubrication and maintenance point map.....	HK-72
5.3	ADR - COLAERT HydrOK series oil hydraulic suspensions	HK-73
5.3.1	HydrOK oil hydraulic suspension layout	HK-73
5.3.2	Lubrication and maintenance point map.....	HK-73
5.4	ADR - COLAERT HydroEVO series independent arm hydraulic suspensions	HE-79
5.4.1	HydroEVO series suspension maintenance work summary table	HE-79
5.4.2	ADR - Colaert independent arm hydraulic suspension layout	HE-80
5.4.3	Lubrication and maintenance point map.....	HE-80

Information

Axles

Bogies

suspensions K

Hydro



1 Important information

1.1 General information

This manual contains the main maintenance information applicable to ADR - Colaert axles, ADR - Colaert mechanical type suspensions and ADR - Colaert hydraulic suspensions.

The maintenance intervals indicated in the maintenance instructions must be followed to keep the vehicle in safe conditions and in full efficiency for road circulation.

This manual should be kept with care.

In the event damages makes the copy of this manual in your possession unusable, the user can request a copy from customer service, specifying the type of product and serial number indicated on the product identification plate. Please contact customer service for information on updates ADR - Colaert has made to its products. In any event, the latest version of this maintenance manual can be found in the *download* section on site www.adraxles.com.

ADR SPA
Customer service
Tel: +39 02 9617 11
Fax: +39 02 9617 1420
E-mail: customer care@adraxles.com

ADR - Colaert cannot be held liable for damages caused by:

- improper product use;
- use by unqualified and/or unskilled personnel;
- incorrect installation (if by the customer);
- inadequate product maintenance or cleaning;
- unauthorised alterations or work;
- incorrect manoeuvres;
- use of non original spare parts;
- use of unforeseen accessories or not authorised in writing;
- full or partial failure to follow the instructions;
- exceptional events.

1.2 Warranty conditions

As a memorandum for the user, ADR - Colaert guarantees the technical specifications, part quality and good supplied product operations according to the stated parameters.

The manufacturer's warranty does not cover all parts whose repair or replacement is due to natural part wear or defects due to incorrect product use by the customer such as, for example but not limited to:





- unauthorised alterations;
- use other than that indicated by ADR - Colaert;
- product overloads beyond that indicated by ADR - Colaert;
- negligent or poor product part maintenance;
- work on products inconsistent with ADR - Colaert instructions;
- failure to replace parts subject to wear, etc.

Please remember that every alteration to the vehicle voids original approval and requires new approval or forfeit the vehicle registration card until standardised.

In the event product defects are found, the customer must communicate them in writing.

This manual was originally drafted in Italian and it is the only official language for which the manufacturer is liable in the event of translation inconsistencies.

1.3 Symbols and terms used in the manual

	Warning Indicates instructions that only if correctly followed avoid personal hazard situations , provides information on hazards and how to avoid them , suggests performance procedures.
	Attention to tightening torque Indicates the tightening torque values to be applied to certain products to avoid personal hazard situations, potential inefficiencies and product break downs .
	Wrench Indicates ordinary and scheduled maintenance procedures to be performed in safe conditions. These must be performed by an authorised individual trained for this purpose.
	Lubricant grease Indicates ordinary and scheduled greasing procedures (lubrication with grease) to be performed in safe conditions. These must be performed by an authorised individual trained for this purpose.
	ADR - Colaert customer service Indicates the need to contact ADR - Colaert customer service. In the event of particularly important part maintenance to guarantee normal product operations, contact ADR - Colaert to set a service appointment on the customer's premises.

1.4 Suggestions for your safety

Vehicle repairs and maintenance may expose operators to unforeseen problems. This warning only illustrates some potential hazards and its purpose is to make users aware of risks that may occur and guide them towards reasonable behaviour to promote safety.

ADR - COLAERT recommends having maintenance performed by specialised departments.

Important: Never overload your car. The chassis, axles and breaks may suffer damages.

Never exceed the total vehicle weight admitted by the manufacturer, nor the maximum speed set by circulation rules. Your vehicle will thus operate in maximum safety, will always brake efficiently and reliably even on long descents. Tyre wear will be even and driving stability with many curves will always be ensured. Place the load to evenly distribute the load on all wheels as much as possible. This achieves higher and safer driving performance, longer lasting tyres and the tractor will save fuel.

Only use tyres of the type and size indicated by the vehicle manufacturer according to axle design requirements. The use of wheels with disc offset must be authorised by the manufacturer. Constantly check braking system efficiency, periodically checking brake gasket wear, lever regulation and control cylinder conditions.

Personal protection: Wear all the equipment and protections necessary: goggles, masks, gloves, helmets, safety shoes, protective clothing, etc.; Work in pairs of two.

Unstable vehicles: Never work under or near a vehicle that was only lifted by a jack.

When working under or near a lifted vehicle, always make sure the jack used is associated with supports or suitable blocks and that the material used is suited to the lifted load. Make sure the group is perfectly stable and that it will remain so during and after the forces applied to the material during maintenance. Also ensure ground stability.



Hot parts: Be careful of parts that may become very hot during use such as, for example, brake drums.

Pressurised, hydraulic or pneumatic circuit: before working on the hydraulic or pneumatic circuit, oil and air may be pressurised, take all the necessary precautions to avoid accidental jets.

Risks due to fires, tied to smoke, toxic gas and irritant substances: All fuels are highly flammable and mix vapours explosive. To clean or degrease parts, only use retail products suited for this purpose and follow the instructions on the packaging. Never put these products into contact with skin and never inhale vapours, smoke or gas.

WARNING: Smoking, the use of flames, producing sparks, etc. causes **explosion or fire hazards** due to vapours, fuels, oils, paints, solvents, dust, straw, etc.; keep an extinguisher at hand at the work site to meet these risks.

Asbestos: Our axle brake gaskets no longer contain asbestos and this long before European community provisions banned its use. In the event of doubt on asbestos (working on old material for example), handle parts as if they contained it, asbestos dust is extremely hazardous to health.

Ecology: Much care and focus was placed on the analysis of the negative effects of our products' impact on the environment. Similarly, do not discard oil, grease and used products in the environment, respect nature and the rules. Discard them at a collection point, dump or recycling area. In order to receive the address of your nearest point, contact your local environmental service agency.

1.5 Product identification data

Product identification data is indicated on a specific **identification plate**, affixed and riveted to the product. Each **identification plate**, for both axle and suspension identification, indicates the items illustrated below.

1.5.1 Axle identification plate

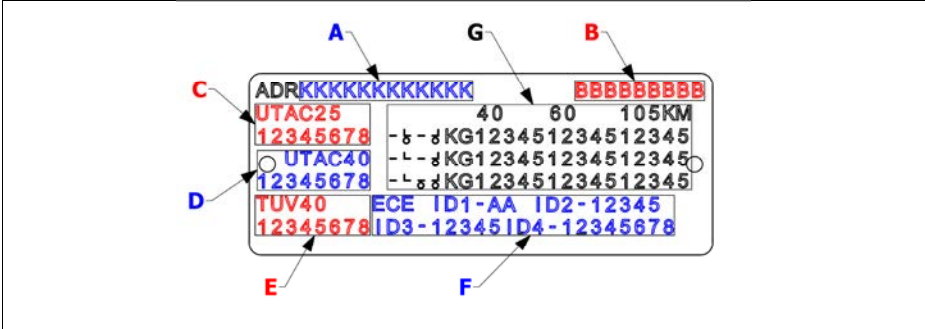

1.5.2 Suspension identification plate

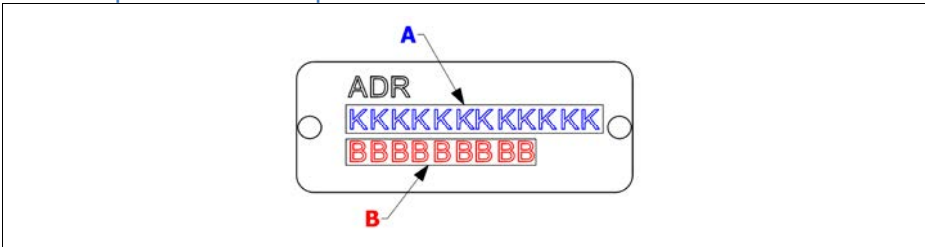

1.5.3 Product identification plate reading

The **axle identification plate** can be read as follows:

- **A** : axle identification code, the code is made up of 12 alphanumeric characters;
- **B** : order identification code, the code is made up of 9 alphanumeric characters;
- **C** : UTAC approval report identification code at 25 km/h, the code is made up of 8 characters;
- **D** : UTAC approval report identification code at 40 km/h, the code is made up of 8 characters;
- **E** : StVZO approval report identification code at 40 km/h, the code is made up of 8 characters;
- **F** : ECE-R13 approval identification data;
- **G** : maximum axle capacity data referred to the application and speed.

If your product is an **ADR - COLAERT suspension**, the identification plate can be read as follows:

- **A** : axle identification code, the code is made up of 12 alphanumeric characters;
- **B** : ECE-R13 approval code, the code is made up of 9 alphanumeric characters;

Data on identification plates are indelible or silk screened.

N.B. the data on the plate cannot be ALTERED for any reason.

1.6 Summary of the main international farm vehicle tyre mounting diagrams.

1.6.1 Mount with centring on columns

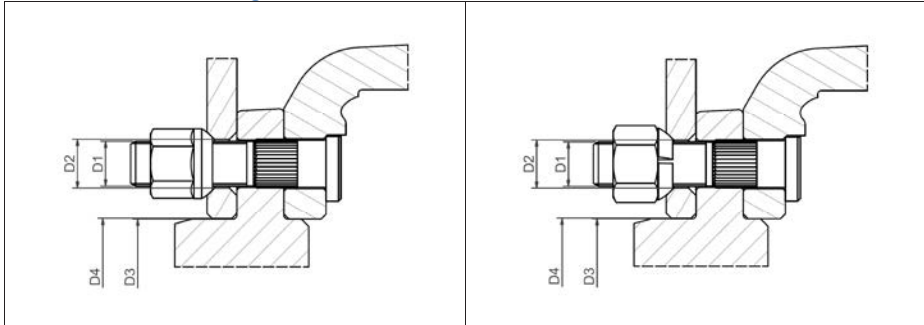

1. Single wheel with DIN nut

2. Single wheel with DIN nut + washer

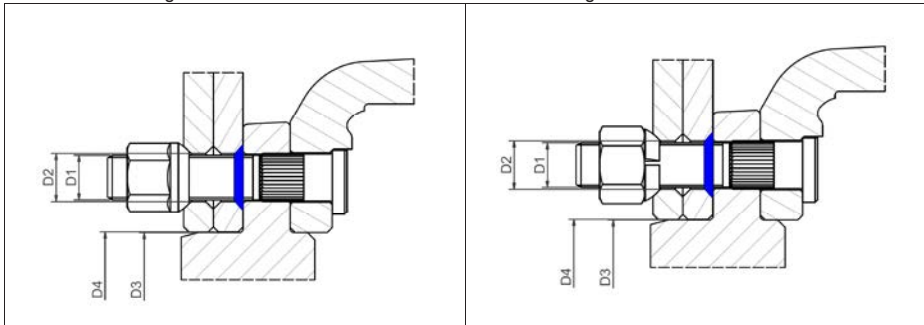

3. Twin wheels with DIN nut¹

4. Twin wheels with DIN nut + washer¹

Fitting	column	wrench	wheel hole	hub centre	wheel centre	Illustration
	D1 (mm)	mm	D2 (mm)	D3 (mm)	D4 (mm)	
4 x Ø 95	M 12 x 1,5	17	16	62	63	1
5 x Ø 140	M 14 x 1,5	19	18.5	93	94	1
6 x Ø 205	M 18 x 1,5	24	21.5	160	161	1 - 3
8 x Ø 275	M 18 x 1,5	24	21.5	220	221	1 - 3
8 x Ø 275	M 18 x 1,5	27	21.5	220	221	2 - 3 - 4
8 x Ø 275	M 20 x 1,5	30	27	220	221	3 - 4
10 x Ø 335	M 22 x 1,5	30	27	280	281	3 - 4

¹ When mounting, always remember to insert the conic centring washer on the column (indicated in blue in the illustration) before the internal wheel, as illustrated.

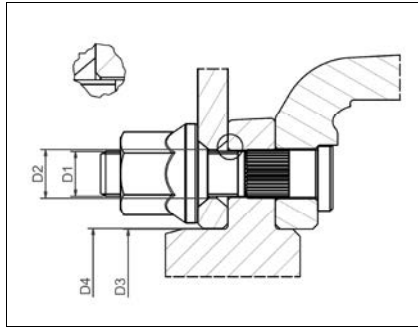

5. Single wheel with conic nut

Fitting	column	wrench	wheel hole	hub centre	wheel centre	Illustration
	D1 (mm)	mm	D2 (mm)	D3 (mm)	D4 (mm)	
8 x Ø 275	M 18 x 1,5	29	21.5	220	221	5
10 x Ø 335	M 22 x 1,5	32	27	280	281	5

1.6.2 Mount with centring on hub

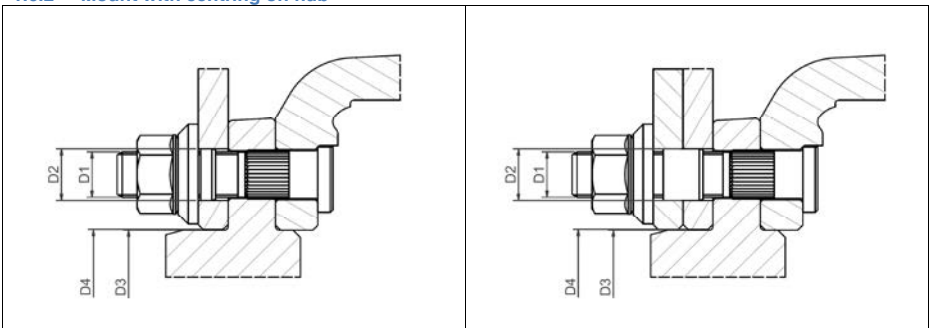

6. Single wheel with ISO nut

7. Twin wheels with ISO nut



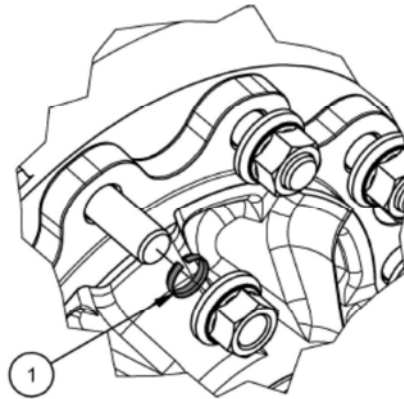















Fitting	column	wrench	wheel hole	hub centre	wheel centre	Illustration
	D1 (mm)	mm	D2 (mm)	D3 (mm)	D4 (mm)	
8 x Ø 275	M 20 x 1,5	28	27	220.5	211	6 - 7
10 x Ø 225	M 22 x 1,5	32	27	175.5	176	6 - 7
10 x Ø 335	M 22 x 1,5	32	27	280.5	281	6 - 7
10 x Ø 335	M 24 x 1,5	36	27	280.5	281	6 - 7



Wheel mounting with centring on hub can be facilitated by the introduction, at least in two columns, of the indicated centring rings, reference 1 in the illustration. This is useful especially when mounting twin wheels since the disc offset could make hub positioning problematic.

2 Axles ADR - Colaert Fixed axle series/Steering axle series

2.1 ADR - Colaert maintenance work summary table

Rigid and steering axle lubrication and maintenance table  Lubrication  Maintenance	After the first 10 km of use at full load.	After the first 200 working hours or first 300 km travelled.	Every 500 working hours or every 8500 km travelled. ¹	Every 1500 working hours or every 25000 km travelled. ¹	Every 3000 working hours or every 50000 km travelled. ¹
Lubrication with special ADR Lithogrease 3 grease					
A – grease change in hub bearings					
B – brake cam supports					
C – brake levers					
D – steering rod joints					
E – steering hinges					
Maintenance					
1 – Wheel nut torque check					
2 – brake gasket check					
3 – bearing gap check and any adjustments					
4 – brake lever stroke check and any adjustments					
5 – steering hinge gap check and any adjustments					
6 – shock absorber end screw torque check					
7 – steering control cylinder fastening screw torque check					
8 – steering rod end screw torque check and steering angle adjustment					
9 – brake cylinder support screw torque check					

¹ For each instruction, increase check frequency in the event of heavy duty use.

2.2 Rigid axle: Lubrication and maintenance point map

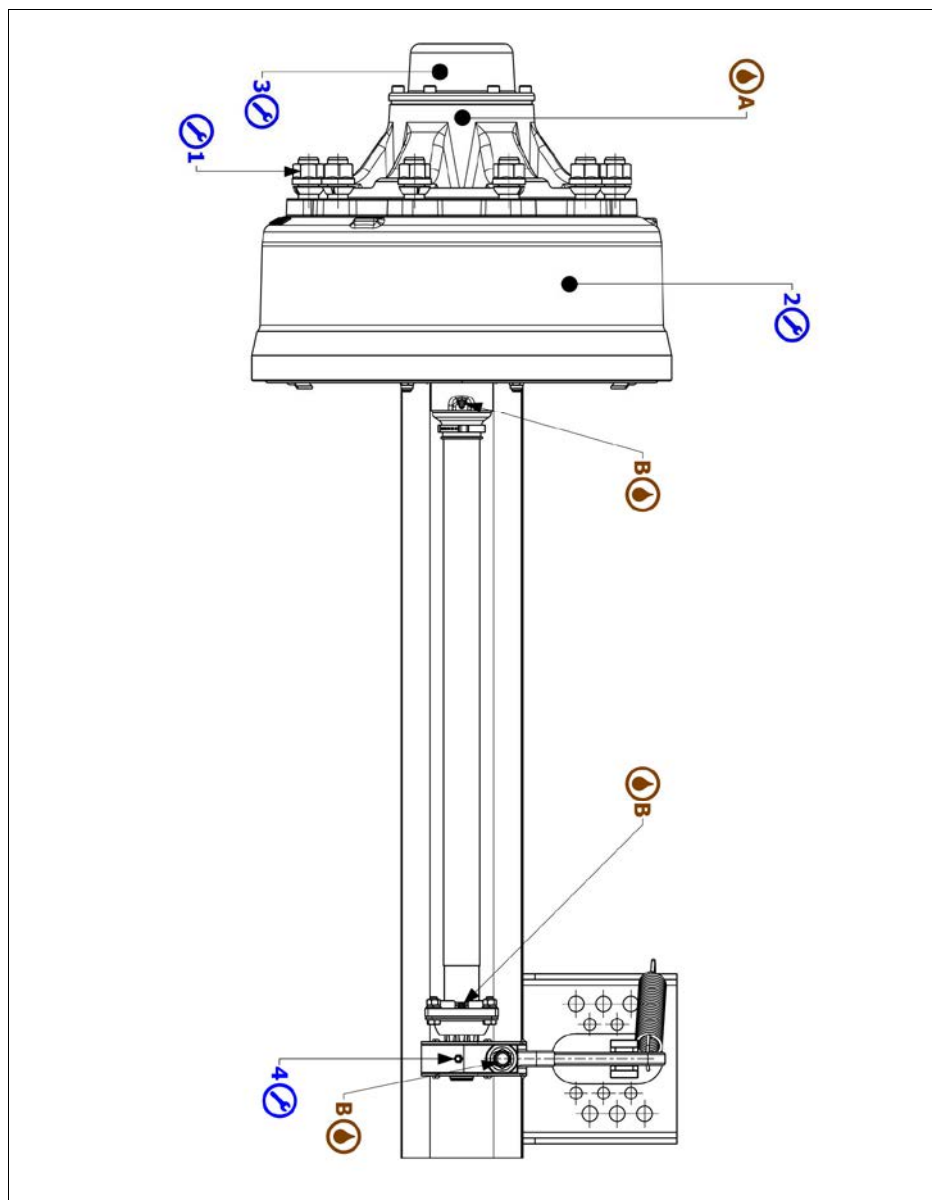

2.3 Dual Mode steering axle: Lubrication and maintenance point map

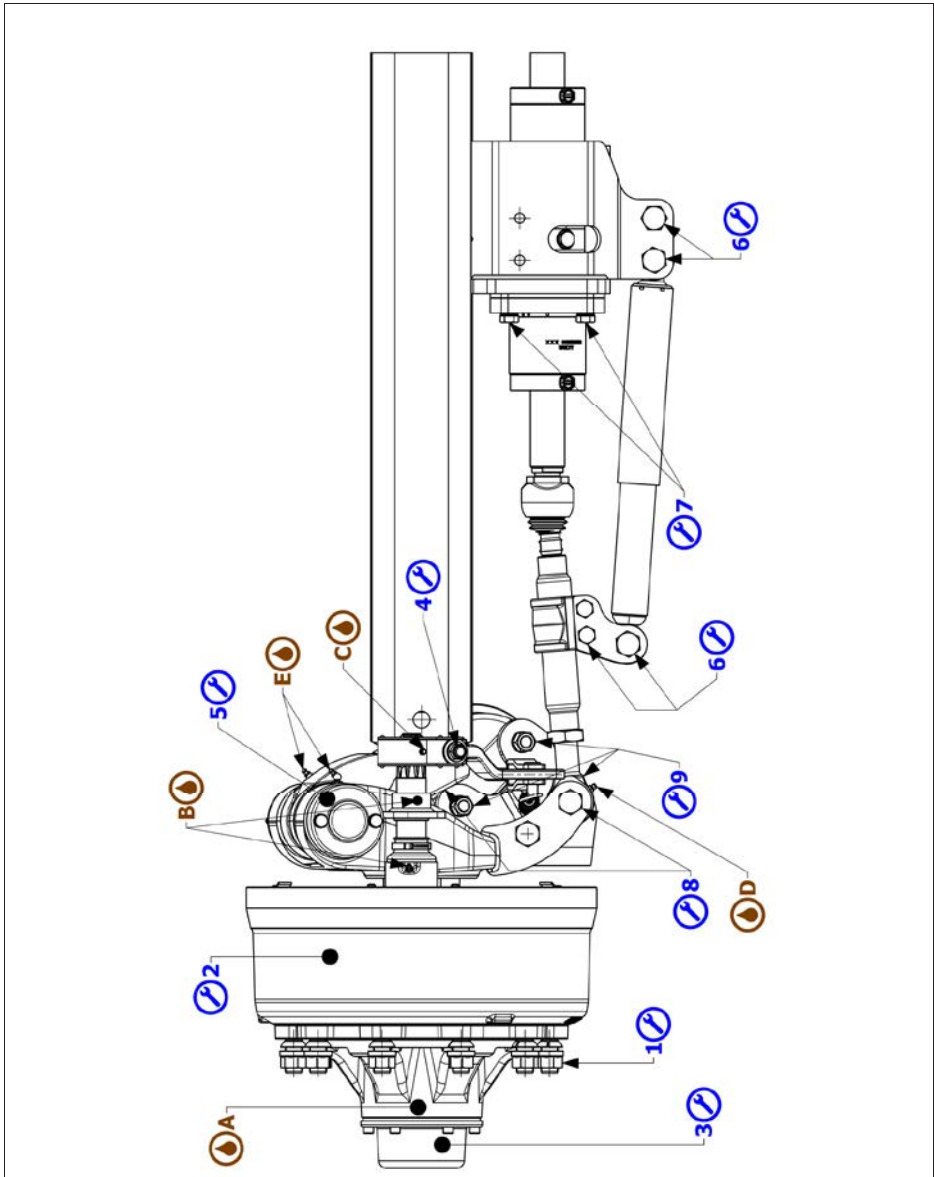

2.4 Standard self-steering axle: Lubrication and maintenance point map

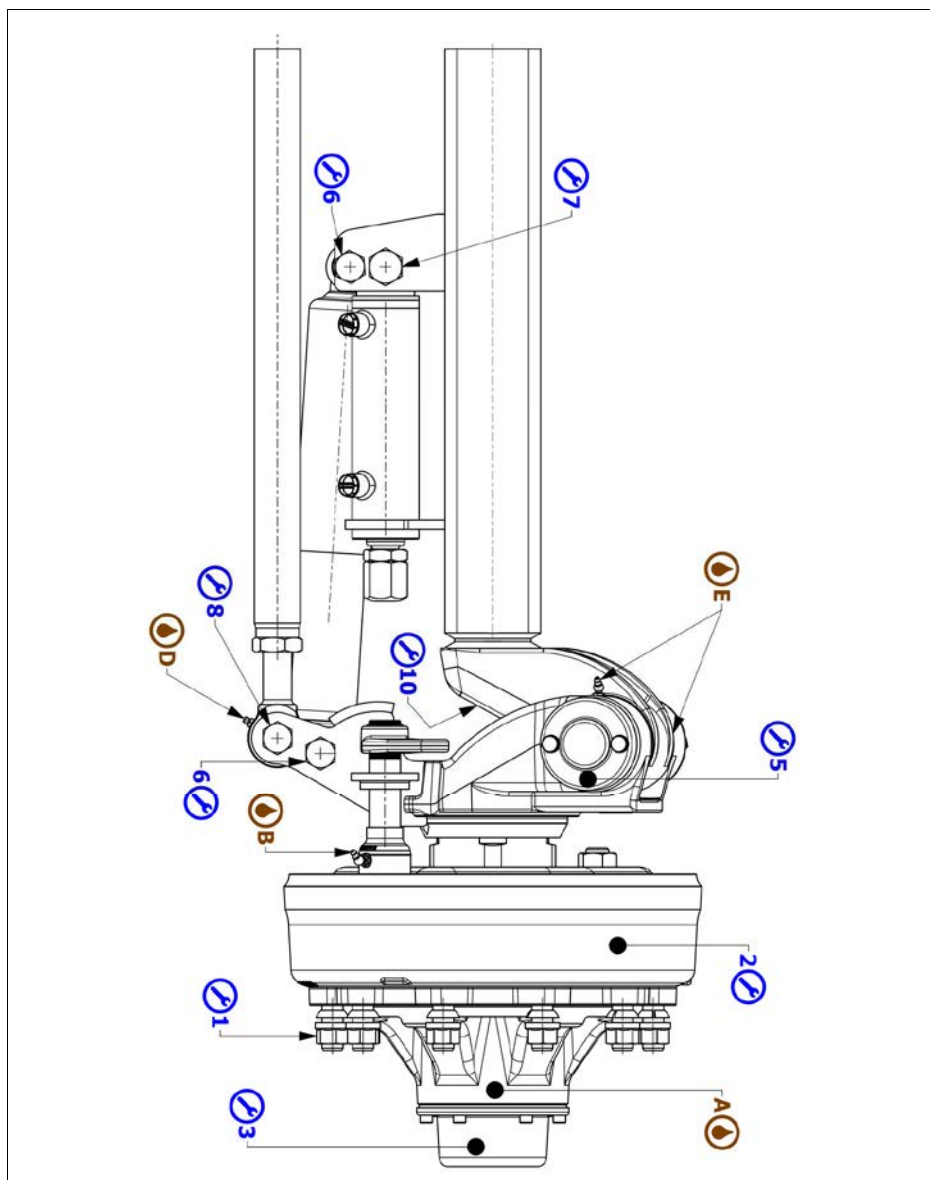

1. Wheel nut torque check.

After the first 10 km at full load, every wheel change and every 500 working hours (or every 8500 km travelled) and not over one year of use.

Tighten the wheel nuts as indicated in the table below, using a torque wrench. If a torque wrench is not available, use a pipe wrench with an extension. In the second to last column on the right of the table is the length of the lever corresponding to the required tightening torque, calculated for force $F =$ approximately 60 kg.

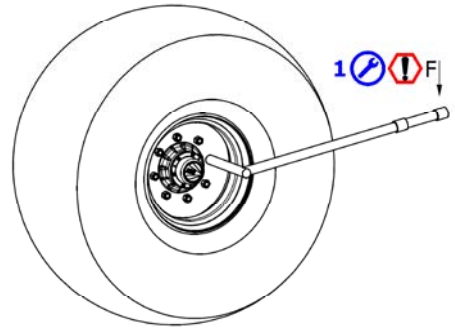
Torque instructions for burnished columns or lined with Dacromet

Wrench (mm)	Number of columns	tightening torque (kgm)	tightening torque (Nm)	lever (mm)	applied force (kg)
17	4 – M 12 x 1,5	9 min – 10 max	90 min – 100 max	450	20
19	5 – M 14 x 1,5	13 min – 15 max	130 min – 150 max	450	30
24	6 – M 18 x 1,5	27 min – 29 max	270 min – 290 max	450	60
27	8 – M 20 x 1,5	35 min – 38 max	350 min – 380 max	600	60
30	10 – M 22 x 1,5	45 min – 51 max	450 min – 510 max	800	60
36	10 – M 24 x 1,5	55 min – 61 max	550 min – 610 max	920	60

Torque instructions for galvanised columns

Wrench (mm)	Number of columns	tightening torque (kgm)	tightening torque (Nm)	lever (mm)	applied force (kg)
17	4 – M 12 x 1,5	9 min – 10 max	90 min – 100 max	450	20
19	5 – M 14 x 1,5	15 min – 17 max	130 min – 150 max	450	30
24	6 - M 18 x 1,5	30 min – 34 max	300 min – 340 max	500	60
27	8 – M 20 x 1,5	40 min – 44 max	400 min – 440 max	700	60
30	10 – M 22 x 1,5	50 min – 56 max	500 min – 560 max	900	60
36	10 – M 24 x 1,5	60 min – 66 max	600 min – 660 max	1050	60



2. Brake gasket check.

Every 500 working hours (or every 8500 km travelled).

Check brake friction gasket wear. Open both inspection windows on the back of the brake and check friction material thickness outside the reference line.



The reference line should always be well visible and, for vehicle safety, it is best to replace the brake friction gaskets when material thickness outside the line is reduced to 2mm. Always use original friction gaskets of the same type as those to be replaced.

Friction gasket features are indicated next to the gasket inside the reference line.

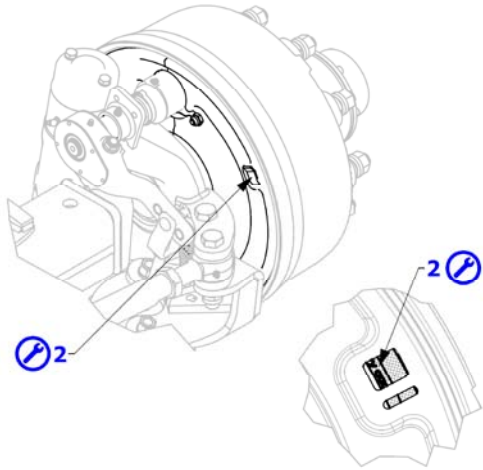

3. Bearing gap check (version with press-in hub cap)

After the first 200 working hours at full load (or after the first 300 km travelled), afterwards every 1500 hours (or every 25000 km travelled).

Make sure the wheel bearings do not rock. This check is performed by lifting the axle with a jack until the wheel is off the ground and rotates freely. Insert a lever between the ground and tyre and force the wheel up to find any gaps.

Bearing gap adjustment

- remove the hub cap
- remove the elastic stop pin on the rack nut
- tighten the rack nut while simultaneously rotating the wheel until the hub is slightly braked
- rotate the rack nut until a slot with the hole on the spindle is found and insert the elastic pin. Make sure the hub rotates manually with slight resistance - top up **ADR Lithogrease 3** grease on the visible part of the bearing and reassemble the press-in hub cap.

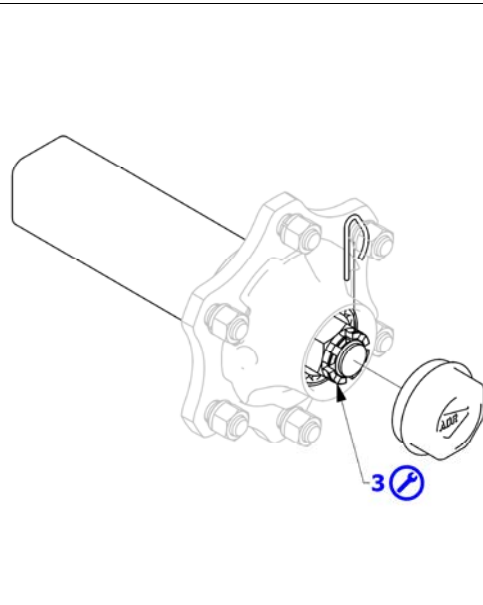



3. Bearing gap check. (version with flanged hub cap)

After the first 200 working hours at full load (or after the first 300 km travelled), afterwards every 1500 hours (or every 25000 km travelled).

Make sure the wheel bearings do not rock. This check is performed by lifting the axle with a jack until the wheel is off the ground and rotates freely. Insert a lever between the ground and tyre and force the wheel up to find any gaps.

Bearing gap adjustment

- remove the flanged hub cap removing the 6 screws;
- remove the elastic stop pin on the rack nut;
- tighten the rack nut while simultaneously rotating the wheel until the hub is slightly braked;
- rotate the rack nut until a slot with the hole on the spindle is found and insert the elastic pin. Make sure the hub rotates manually with modest resistance;
- top up **ADR Lithogrease 3** grease on the visual part of the bearing and reassemble the hub cap being careful that its seal gasket is integral. If damaged, replace the gasket with an **ADR original spare part**;
- reassemble the hub cap and tighten the 6 screws.

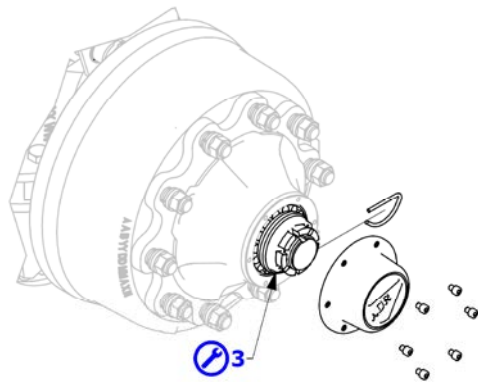



3. Bearing gap check

(Teknoax version with screw-in hub cap).

After the first 200 working hours at full load (or after the first 300 km travelled), afterwards every 1500 hours (or every 25000 km travelled).

Make sure the wheel bearings do not ruck. This check is performed by lifting the axle with a jack until the wheel is off the ground and rotates freely. Insert a lever between the ground and tyre and force the wheel up to find any gaps.

Bearing gap adjustment

- remove the 3.6 hub cap and 3.5 gasket.
- remove the 3.4 stop screws and 3.3 rack.
- tighten the 3.2 rack nut while simultaneously rotating the wheel until the hub is slightly braked.
- reposition the 3.3 rack and secure it to the 3.2 rack nut with the 3.4 screws. Make sure the hub rotates manually with modest resistance.
- Top up **ADR Lithogrease 3** grease on the visual part of the bearing and reassemble the 3.6 hub cap being careful that its seal gasket is integral. If damaged, replace the gasket with an **ADR original spare part**.

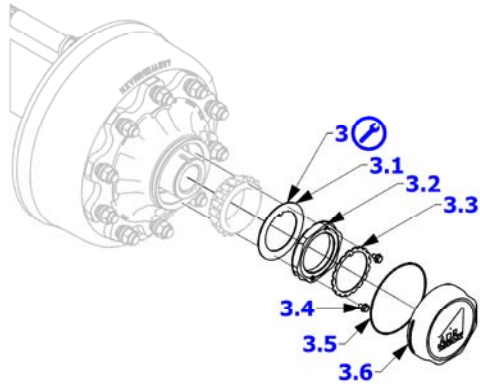



A. Grease change in hub bearings.

Every 3000 working hours (or every 50000km travelled).

As with the bearing gap check, lift the axle with a jack until the wheel rotates freely, then:

Flanged hub cap version

1. remove the hub cap;
2. remove the elastic stop pin on the rack nut;
3. remove the rack nut;

Teknoax version

1. remove the hub cap and gasket;
2. remove the stop screws and rack;
3. remove the threaded rack nut;

4. remove the hub complete with drum and bearings from the spindle;
5. perform this operation on one wheel at a time to avoid exchanges components between one wheel and the next. When simultaneously removing several wheel, mark the bearing cages to avoid incorrectly reassembling them;
6. clean the brake, check general conditions and wear. Replace any worn or damaged parts, eliminate any lubricant residue that could jeopardise good brake operations;
7. remove all used grease residue, clean the bearings and gaskets, replace damaged parts;
8. grease the conic housings and bearing rollers as indicated in the illustration, using **ADR Lithogrease 3** grease, the amount necessary for each bearing is about 150g;
9. reassemble all parts as indicated in the illustration with the help of bushings to avoid alignment errors that could damage bearings.
10. before reassembling the rack nut (flanged hub cap version) or threaded nut (Teknoax version), apply a layer of grease on the bearing, reassemble and adjust the nut as indicated in point **3-Bearing gap adjustment**.

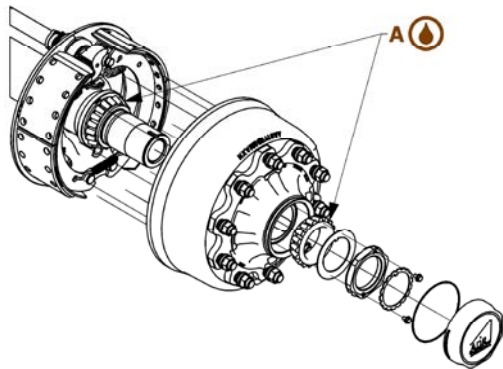
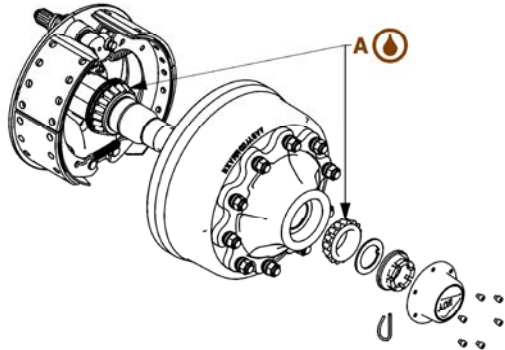

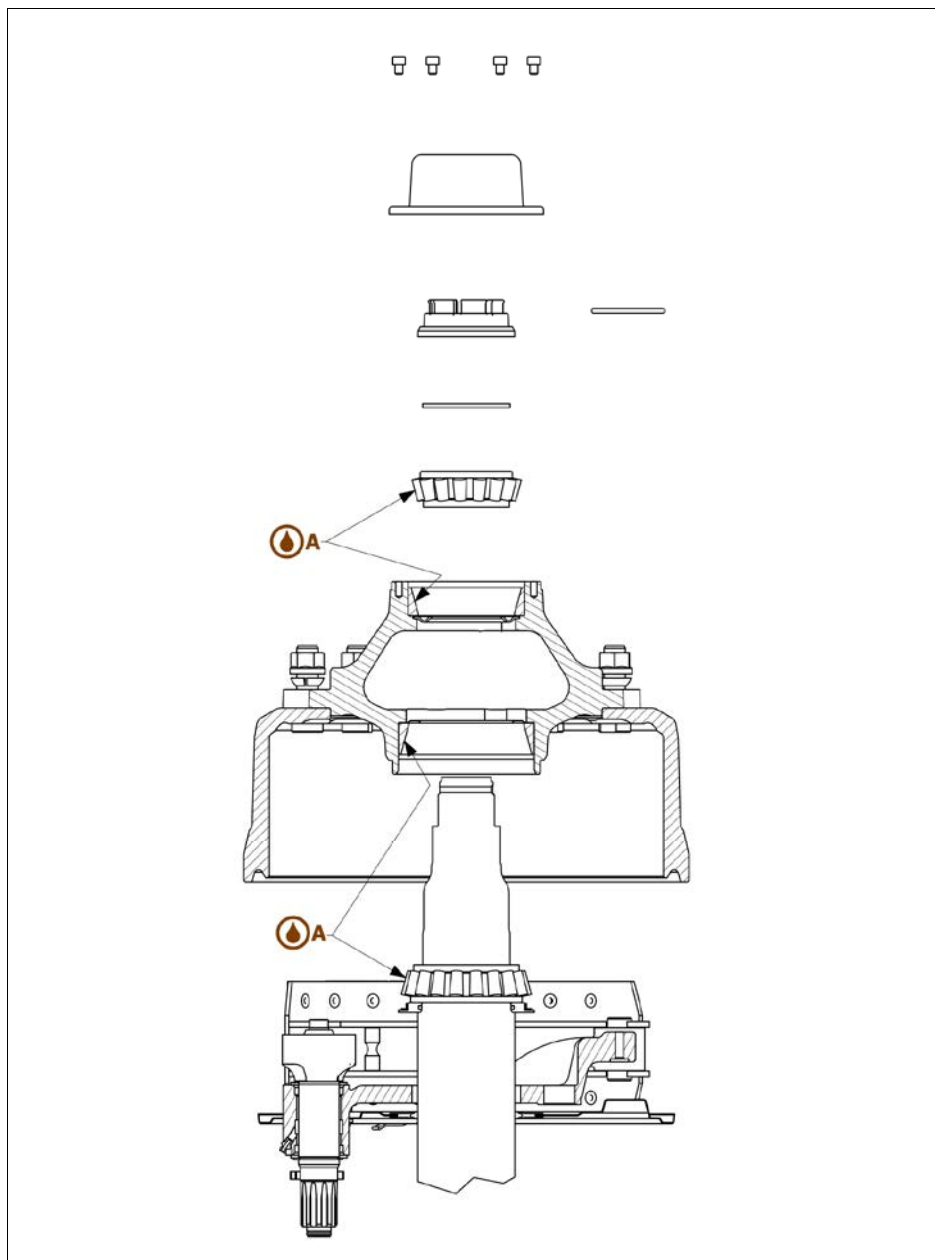



B. Brake cam support lubrication.

Every 500 working hours (or every 8500 km travelled) and before starting after a long period of disuse.

Lubricate the points indicated in the illustration with **ADR Lithogrease 3** grease. Lubricate the supports so that new grease leaks from the housings.



Grease and oil penetration in the brake is not admitted.

Repeat the operation even after each vehicle wash with high pressure equipment.

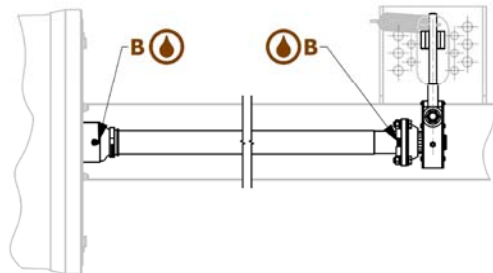
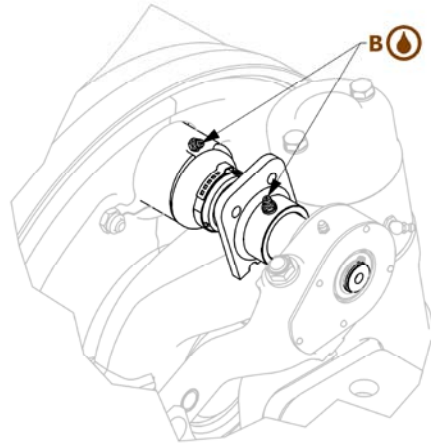



4. Brake lever stroke check and any adjustments

Every 500 working hours (or every 8500km travelled).

Make sure the brake cylinder rods do not exceed, with full brake, 40 mm - 45 mm.

Stroke must be adjusted using the register screw indicated in the illustration, rotating it with a wrench until it stops at the brake block contact with the drum. The register screw has a jack, thus from the end stroke position, loosen the register screw about 2 clicks and make sure the stroke corresponds to the instruction when adjusted.



C. Lubrication.

Every 500 working hours (or every 8500km travelled).

Lubricate the registration mechanism with **ADR Lithogrease 3** grease through the grease point indicated in the illustration.



Repeat the operation even after each vehicle wash with high pressure equipment.

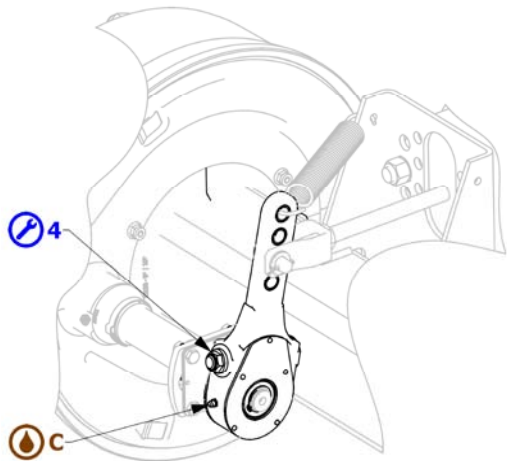

E. Grease steering hinges.

Every 500 working hours (or every 8500km travelled).

Lubricate with **ADR Lithogrease 3** grease using the grease points indicated in the illustration until new grease leaks from the housings.



Repeat the operation even after each vehicle wash with high pressure equipment.

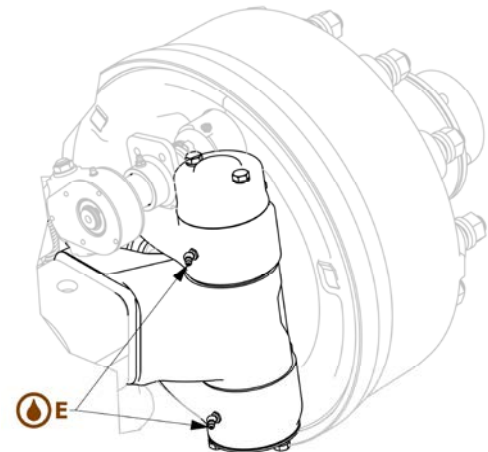



5. steering hinge gap check and any adjustments.

After the first 10 km at full load, afterwards every 1500 working hours (or every 25000km travelled).

Check that the gap between the steering arm and relevant support is not under 2 mm as indicated in the illustration with the car empty and in drive. If the gap is smaller, adjust the hinge pin as follows:

- remove the cover III;
- loosen the screw V to free regulation nut rotation IV;
- rotate the nut clockwise to restore the required gap;
- block the nut with the screw V;
- reassemble the cover III and secure it with the screws I and elastic washers II;
- if the O-ring in the cover III is damaged, **replace it with an original ADR - Colaert spare part.**

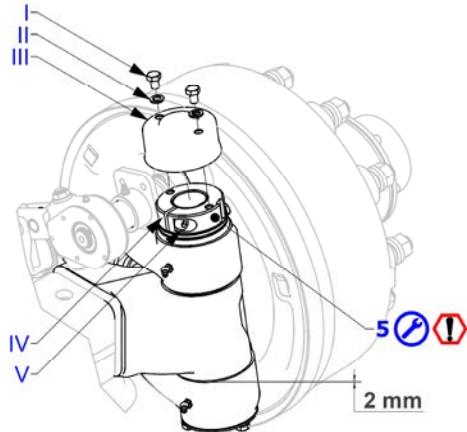

Torque instructions for the regulation nut IV and lock screw V

Part	Axle series	Thread	Tightening torque (Nm)
IV	Light	M42	350 ± 10
	Average	M48	450 ± 10
	Heavy	M55	500 ± 10
	Heavy Duty	M75	600 ± 10
V	All series	M10	78



6. Shock absorber end screw torque check

Every 1500 working hours (or every 25000km travelled).

Check screw torque using a torque wrench and referring to the table at the bottom of the page. The two possible variations are illustrated



If the self-locking nuts loosen with the nylon ring, replace the loose nuts with ADR - Colaert original spare parts. Check shock absorber end silent block conditions, if worn or damaged replace the shock absorber with an ADR-Colaert original spare part.

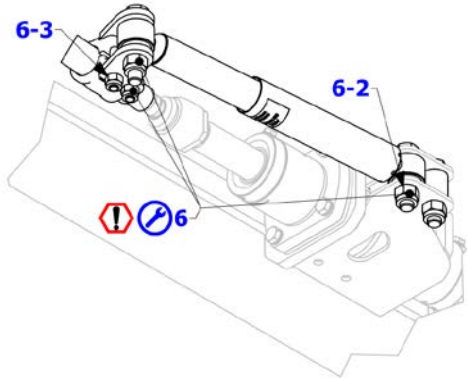
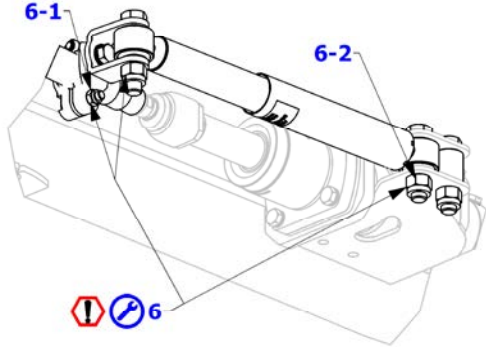

Part torque instructions

id	screw	wrench	Number of parts to be tightened	tightening torque (kgm)	tightening torque (Nm)
6-1	M 12	19	1	7 min / 9 max	70 min / 90 max
6-2	M 20	30	3	40 min / 45 max	400 min / 450 max
6-3	M 14	21	2	12 min / 15 max	120 min / 150 max
7	M 14	21	4	18 min / 20 max	180 min / 200 max

7. Steering control cylinder fastening screw torque check

Every 1500 working hours (or every 25000km travelled).
Check screw torque indicated in the illustration with a torque wrench. Steering cylinder fastening screw torque is indicated in the table on the previous page.

Part torque instructions

id	screw	wrench	Number of parts to be tightened	tightening torque (kgm)	tightening torque (Nm)
8-A	M 20	30	4	40 min / 45 max	400 min / 450 max
8-B	M 18	27	2	58 min / 62 max	580 min / 610 max
9-1-A	M 16	24	4	18 min / 22 max	180 min / 220 max
9-1-B	M 20	30	4	40 min / 45 max	400 min / 450 max
9-2-A	M 20	30	4	40 min / 45 max	400 min / 450 max

Approximate regulation of the steering angle according to quota **L**:

Steering angle	L±1mm		
	Steering type		
	SM	ST	SW
8°	52	47	42
9°	50	44	39
10°	47	42	37
11°	45	39	34
12°	42	37	32
13°	40	35	29
14°	37	32	26
15°	35	30	24
16°	32	27	21
17°	30	25	-
18°	27	22	-



8-A. Steering rod end screw torque check.

Every 1500 working hours (or every 25000km travelled).

Check screw torque indicated in the illustration with a torque wrench, following the instructions in the table at the bottom of the page.



For self-locking nuts with nylon ring, replace the loose nuts with ADR original spare parts.



8-B. Steering angle adjustment.

If required by operating conditions, proceed as follows to change the steering angle.

The steering angle is adjusted using parts **I** and **II** shown in detail in the illustration. Proceed as follows:

- loosen the counter nut **I** until the screw head is reached;
- adjust the admissible steering angle using the screw **II**. For admissible steering angle adjustment values, refer to the table at the bottom of the page;
- tighten the counter nut **I** using a torque wrench following the instructions in the table;
- repeat the operation on the opposite side of the steering axle.



To avoid damaging the steering control cylinder, the maximum steering angle adjustment should never exceed the maximum admitted and indicated in ADR - Colaert technical specifications.



D. Grease steering joints.

Every 500 working hours (or every 8500 km travelled) or after every wash with pressure jets.

Lubricate with **ADR Lithogrease 3** grease using the grease points indicated in the illustration until new grease leaks from the housings.

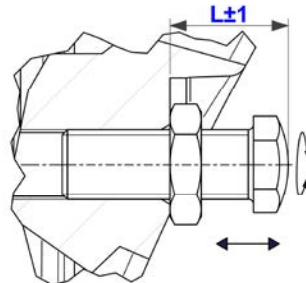
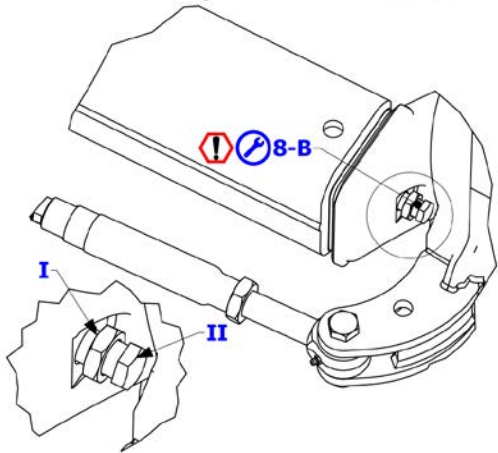
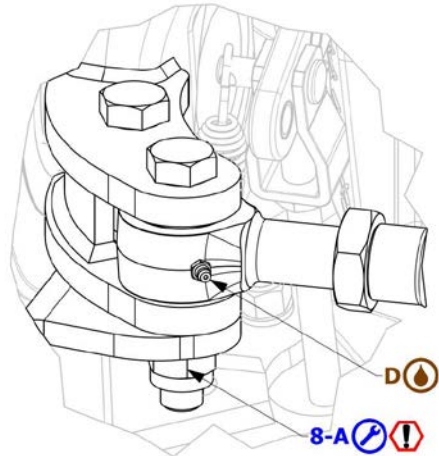

 **9. Brake cylinder fastening screw torque check.**

Ref. 9-1 pneumatic brake system.

Ref. 9-2 oil hydraulic brake system.

Every 1500 working hours (or every 25000km travelled).





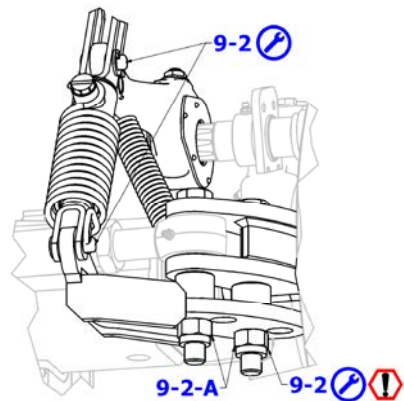
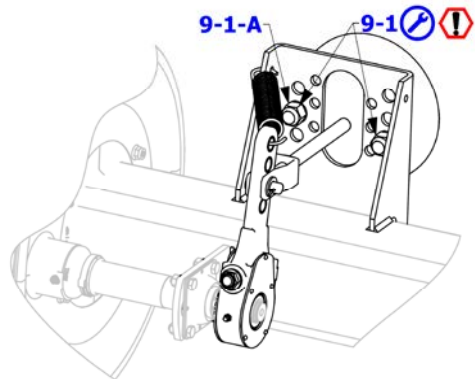
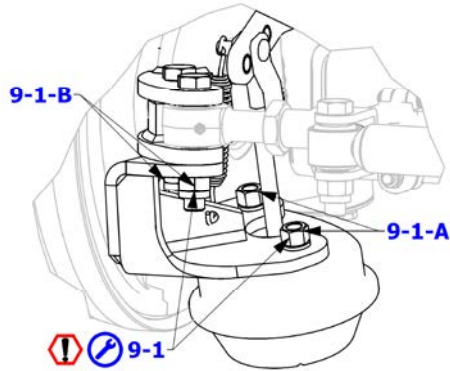















Check screw torque indicated in the illustration with a torque wrench, following the instructions in the table on the previous page.

 If the self-locking nuts loosen with the nylon ring, replace the loose nuts with ADR - Colaert original spare parts.



3 BOGIE ADR - COLAERT mechanical suspensions

3.1 BOGIE ADR - COLAERT maintenance work summary table

Cantilever (Bogies) mechanical suspension lubrication and maintenance table  Lubrication  Maintenance	After the first 10 km of use at full load.	After the first 500 working hours or first 8500 km travelled.	Every 500 working hours or every 8500 km travelled. ¹	Every 1500 working hours or every 25000 km travelled. ¹
Lubrication with special ADR Lithogrease 3 grease				
A – grease central joint				
Maintenance				
0 – visual inspection of the integrity of all components.				
1 – axle anchoring to leaf spring: check correct housing. Check torque with torque wrench				
2 – leaf spring anchoring to the central oscillating support: check correct housing. Check torque with torque wrench.				
3 – threaded pin torque check on central support.				
4 – check leaf spring retention straps and leaf spring alignment.				
5 – check rubber plate wear.				
6 – check bolt torque.				
7 – check bushing wear.				

¹ For each instruction, increase check frequency in the event of heavy duty use.

3.2 Bogie Series B / C / D / E / I / K / L mechanical suspensions

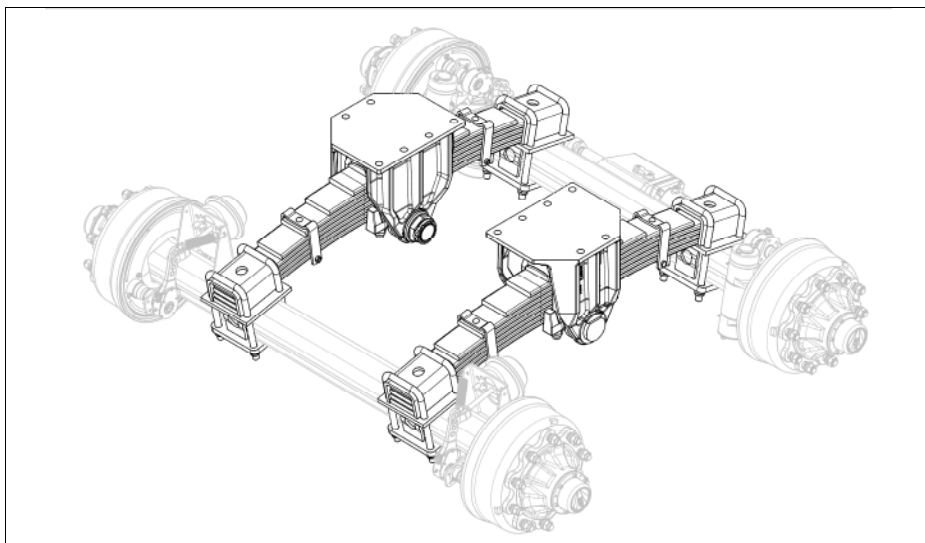

3.2.1 Lubrication and maintenance map

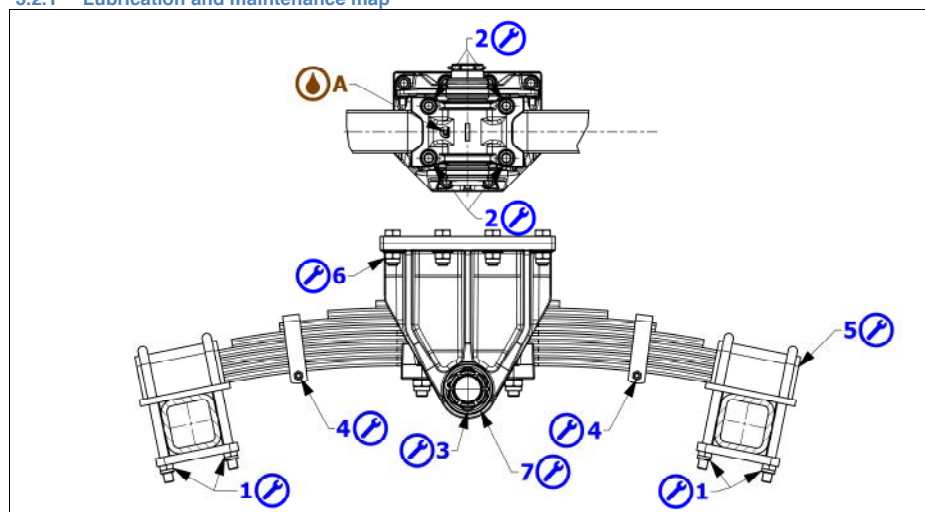



1 - Axle anchoring to leaf spring.

After the first 10 km at full load, after the first 500 working hours (or after the first 8500 km travelled), afterwards every 1500 working hours (or every 25000 km travelled).

Check correct axle anchor housing to the suspension leaf springs and make sure they are correctly tightened. Check torque with a torque wrench according to the diagonals of each anchor.

For tightening torques, refer to the table below.

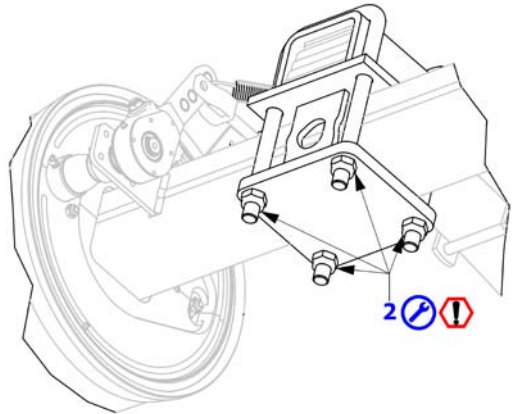

Part torque instructions

U bolt	wrench	tightening torque (kgm)	tightening torque (Nm)
Ø 18	27	23 min / 27 max	230 min / 270 max
Ø 22	34	45 min / 54 max	450 min / 540 max
Ø 24	36	50 min / 60 max	500 min / 600 max
Ø 27	41	60 min / 72 max	600 min / 720 max
Ø 30	46	90 min / 100 max	900 min / 1000 max

2 – Leaf spring anchoring to the central oscillating support.

After the first 10 km at full load, after the first 500 working hours (or after the first 8500 km travelled), afterwards every 1500 working hours (or every 25000 km travelled).

Check correct housing.

Check torque with a torque wrench according to the diagonals of each anchor.

For tightening torques, refer to the previous table.

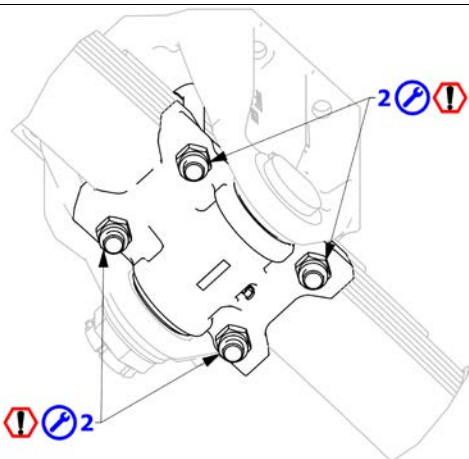

3 - Central support pin.

After the first 10 km at full load, afterwards every 1500 working hours (or every 25000 km travelled).

Threaded pin torque check on central support.



If the support rocks in the housing and/or the bushings are worn, contact **ADR - Colaert customer service**.

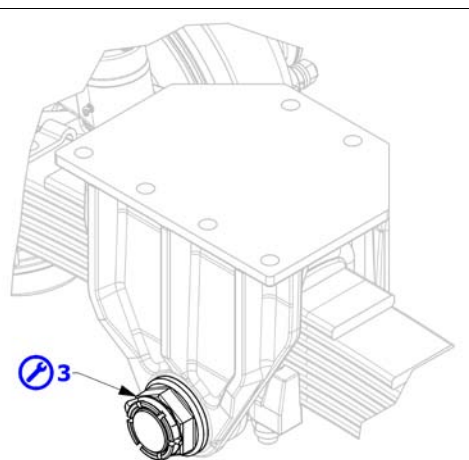



4 – Leaf spring retention straps and leaf spring alignment check.

After the first 10 km at full load, afterwards every 1500 working hours (or every 25000 km travelled).

Make sure they are not damaged and the screws are integral and tight.

Check leaf spring alignment.



In the event of damages, contact **ADR - Colaert customer service.**

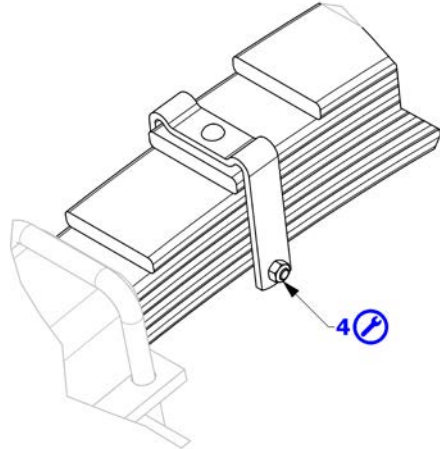

A – Grease central joint

Every 500 working hours (or every 8500 km travelled).

Grease the central joint.

Use **ADR Lithogrease 3** grease pumping through the point indicated in the illustration until new grease leaks from the bushings.

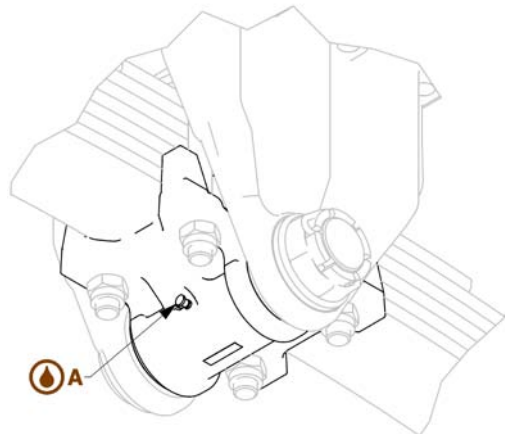



5 – Check rubber plate wear.

Every 3000 working hours (or every 50000 km travelled).

Check plate wear at the ends of the leaf springs as follows:

- unscrew the nuts **I** and remove the clamps **II**;
- remove the housing case **III**;
- check rubber plate wear **5**.

Reassemble the components, tighten the nuts **I** following the instructions in point 1 – **Axle anchoring to leaf springs**.

If the component is crushed or damaged (cut, cracked) replace it.



Perform this operation with the carriage empty inspecting, dismantling and reassembling one house case at a time.



If replacement is needed, contact **ADR - Colaert customer service**.

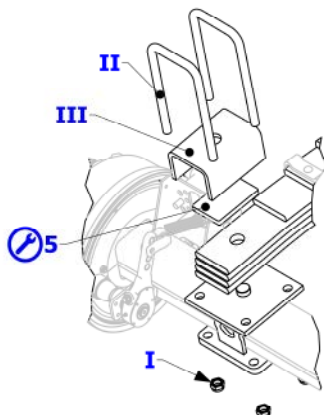

6 – Check bolt torque.

After the first 10 km at full load, after the first 500 working hours (or after the first 8500 km travelled), afterwards every 1500 working hours (or every 25000 km travelled).

In versions with bolted coupling to the vehicle chassis, check torque on all support bolts.

For tightening torque, refer to the table below.



6

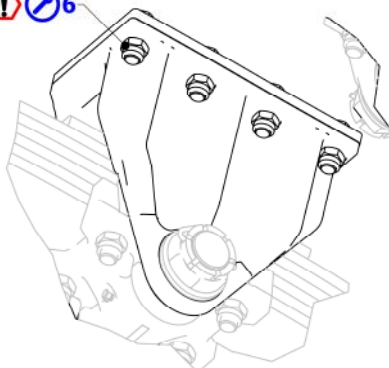

Part torque instructions

screw	wrench	tightening torque (kgm)	tightening torque (Nm)
M 20	30	38 min / 42 max	380 min / 420 max
M 22	34	51 min / 56 max	510 min / 560 max
M 24	36	66 min / 72 max	660 min / 720 max
M 27	41	97 min / 104 max	970 min / 1040 max

7 – Check bushing wear.

Every 3000 working hours (or every 50000km travelled).

Check bushings as described below:

- remove the elastic stop pin **I** and unscrew the rack nut **II**;
 - remove the pin **III** from the housing;
 - remove the leaf spring from the plate **IV**;
 - remove the bushings **7** and check wear.
- If these components are worn or damaged, replace them.



Perform this operation with the carriage empty inspecting by lifting it off the ground.



If replacement is needed, contact **ADR - Colaert customer service**.

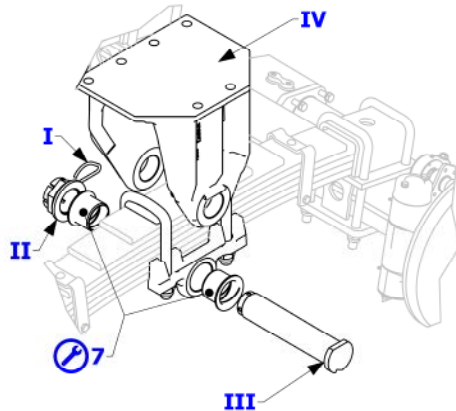

3.3 Bogie Series A / X / Y mechanical suspensions

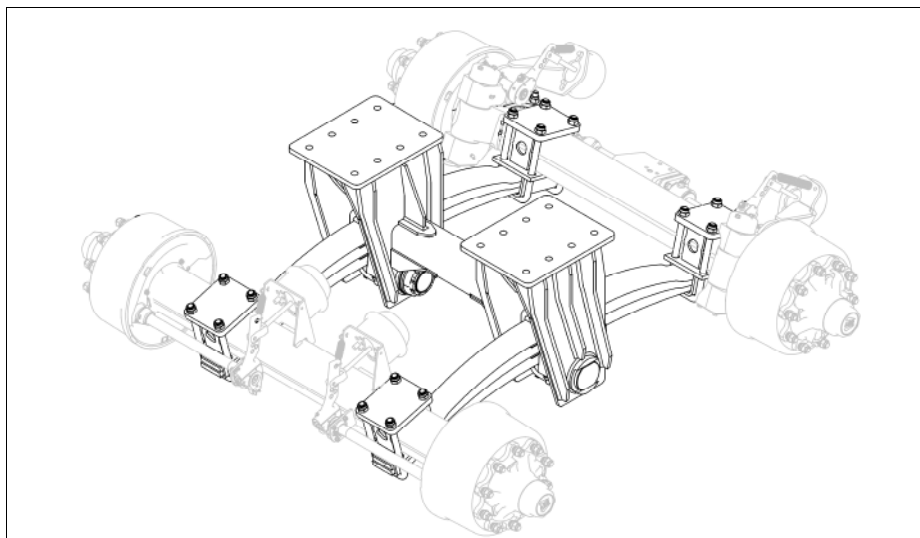

3.3.1 Lubrication and maintenance map

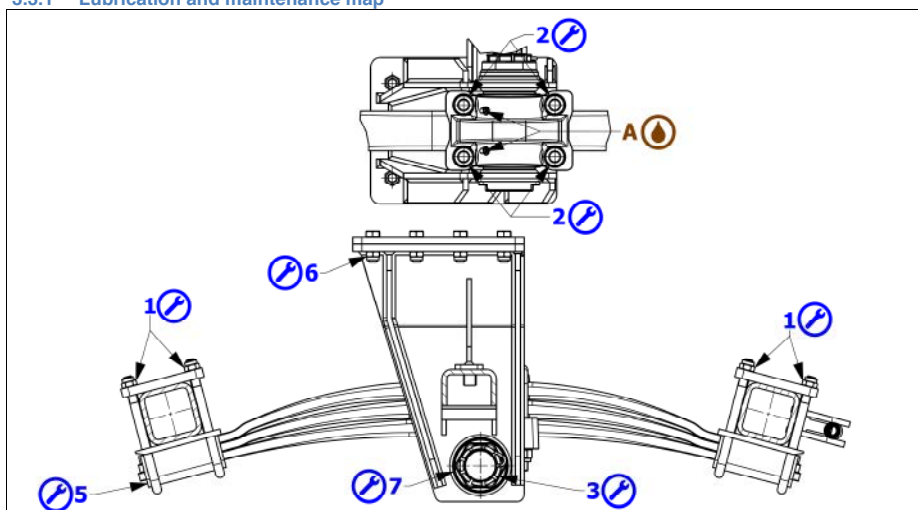

<p> 1 - Axle anchoring to leaf spring.</p> <p>After the first 10 km at full load, after the first 500 working hours (or after the first 8500 km travelled), afterwards every 1500 working hours (or every 25000 km travelled).</p> <p>Check correct axle anchor housing to the suspension leaf springs and make sure they are correctly tightened. Check torque with a torque wrench according to the diagonals of each anchor.</p> <p>For tightening torques, refer to the table below.</p>	
--	--

Part torque instructions

U bolt	wrench	tightening torque (mkg)	tightening torque (Nm)
Ø 18	27	23 min / 27 max	230 min / 270 max
Ø 22	34	45 min / 54 max	450 min / 540 max
Ø 24	36	50 min / 60 max	500 min / 600 max
Ø 27	41	60 min / 72 max	600 min / 720 max
Ø 30	46	90 min / 100 max	900 min / 1000 max



2 – Leaf spring anchoring to the central oscillating support.

After the first 10 km at full load, after the first 500 working hours (or after the first 8500 km travelled), afterwards every 1500 working hours (or every 25000 km travelled).

Check correct housing.

Check torque with a torque wrench according to the diagonals of each anchor.

Refer to the instructions in the previous table for tightening torque.

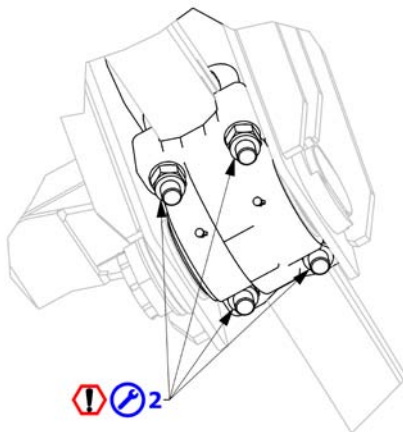

3 - central support pin.

After the first 10 km at full load, afterwards every 1500 working hours (or every 25000 km travelled).

Threaded pin torque check on central support.



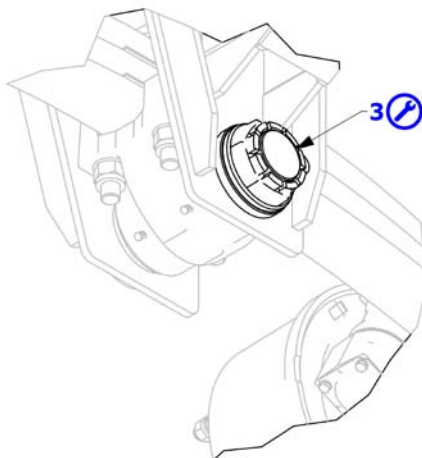

If the support rocks in the housing and/or the bushings are worn, contact **ADR - Colaert customer service**.

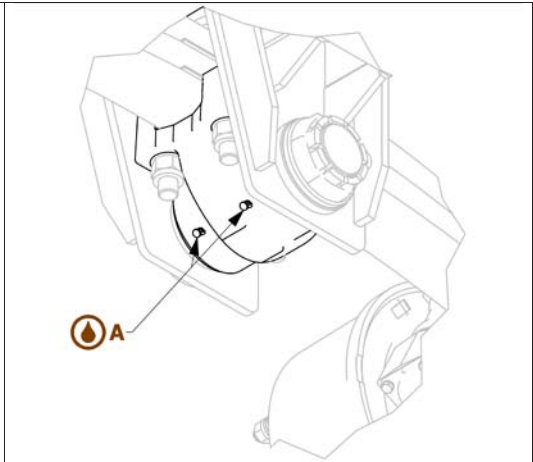

 **A – Central joint**

Every 500 working hours.
Grease the central joint, use **ADR Lithogrease 3** grease pumping through the point indicated in the illustration until new grease leaks from the bushings.





 **5 – Check rubber plate wear.**

Every 3000 working hours (or every 50000 km travelled).
Check plate wear at the ends of the leaf springs as follows:

- unscrew the nuts **I** and remove the clamps **II**;
- remove the housing case **III**;
- check rubber plate wear **5**.

Reassemble the components, tighten the nuts **I** following the instructions in point 1 – **Axle anchoring to leaf springs.**
If the component is crushed or damaged (cut, cracked) replace it.

 **Perform this operation with the carriage empty inspecting, dismantling and reassembling one house case at a time.**

 If replacement is needed, contact **ADR - Colaert customer service.**

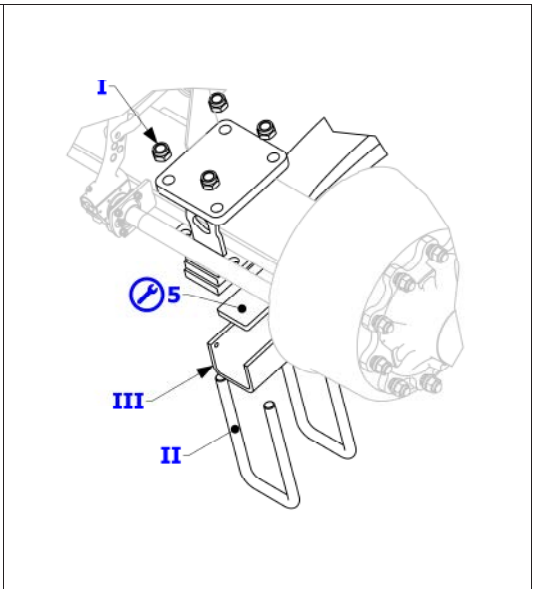



6 – Check bolt torque.

After the first 10 km at full load, after the first 500 working hours (or after the first 8500 km travelled), afterwards every 1500 working hours (or every 25000 km travelled).

In versions with bolted coupling to the vehicle chassis, check torque on all support bolts.

For tightening torque, refer to the table below.

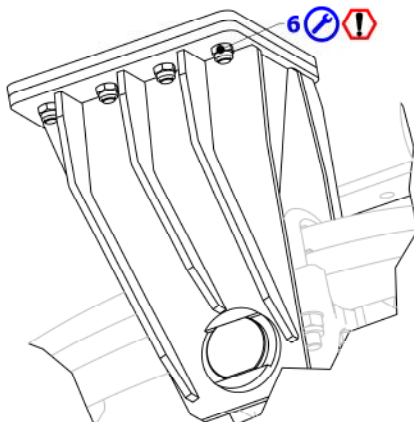

Part torque instructions

screw	wrench	tightening torque (kgm)	tightening torque (Nm)
M 20	30	38 min / 42 max	380 min / 420 max
M 22	34	51 min / 56 max	510 min / 560 max
M 24	36	66 min / 72 max	660 min / 720 max
M 27	41	97 min / 104 max	970 min / 1040 max

 **7 – Check bushing wear.**

Every 3000 working hours (or every 50000 km travelled).

Check bushings as described below:

- remove the elastic stop pin **I** and unscrew the rack nut **II**;
- remove the pin **III** from the housing;
- remove the leaf spring from the plate **IV**;
- remove the bushings **7** and check wear.

If these components are worn or damaged, replace them.



Perform this operation with the carriage empty inspecting by lifting it off the ground.



If replacement is needed, contact **ADR - Colaert customer service.**

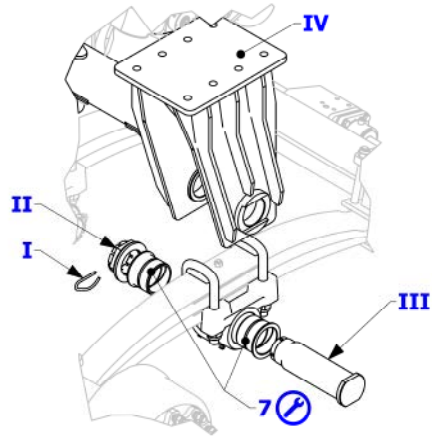

3.4 Bogie Series Z mechanical suspensions

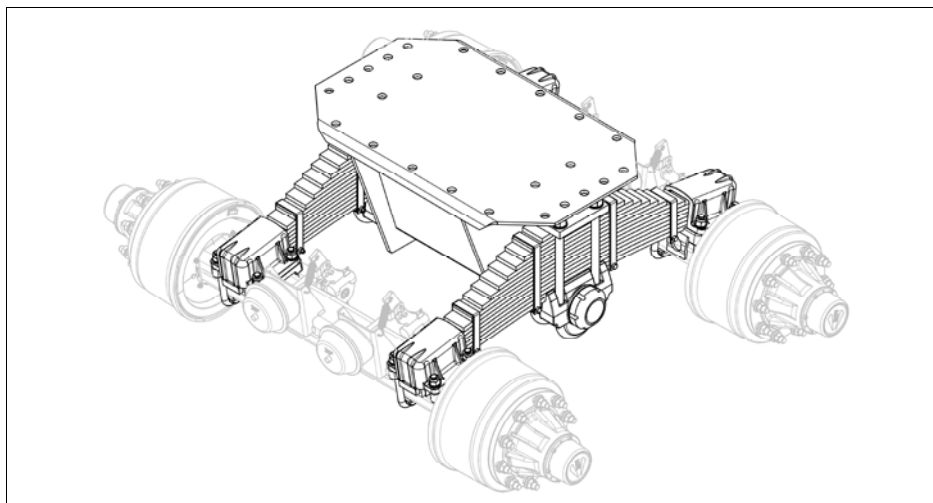

3.4.1 Lubrication and maintenance map

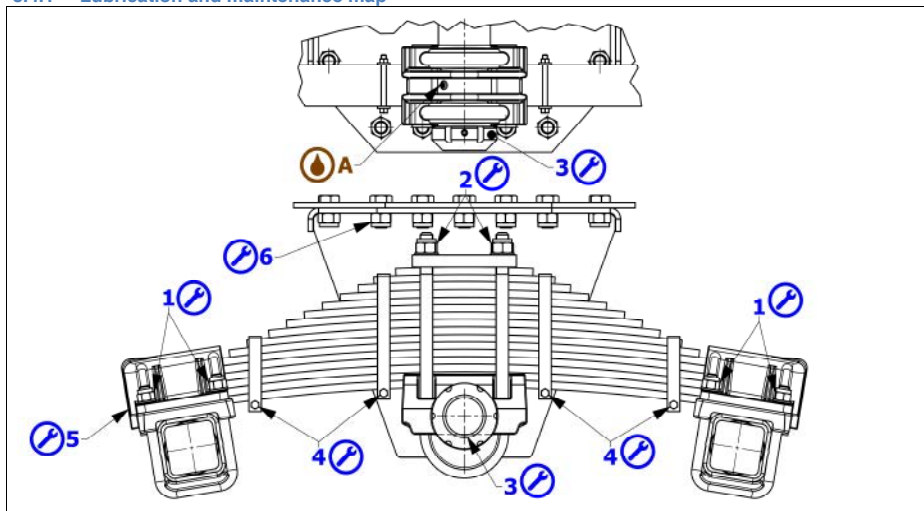



1 - Axle anchoring to leaf spring.

After the first 10 km at full load, after the first 500 working hours (or after the first 8500 km travelled), afterwards every 1500 working hours (or every 25000 km travelled).

Check correct axle anchor housing to the suspension leaf springs and make sure they are correctly tightened. Check torque with a torque wrench according to the diagonals of each anchor.

For tightening torques, refer to the table below.

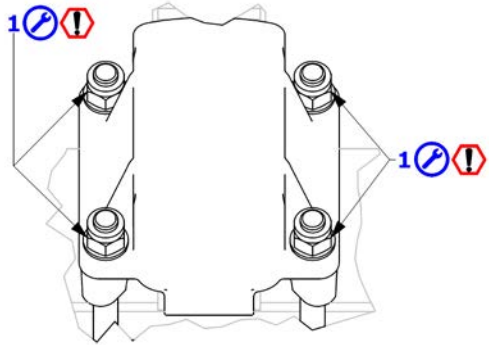

Part torque instructions

U bolt	wrench	tightening torque (kgm)	tightening torque (Nm)
Ø 18	27	23 min / 27 max	230 min / 270 max
Ø 22	34	45 min / 54 max	450 min / 540 max
Ø 24	36	50 min / 60 max	500 min / 600 max
Ø 27	41	60 min / 72 max	600 min / 720 max
Ø 30	46	90 min / 100 max	900 min / 1000 max



A – Central joint

Every 500 working hours (or every 8500 km travelled).

Grease the central joint, use **ADR Lithogrease 3** grease pumping through the point indicated in the illustration until new grease leaks from the bushings.

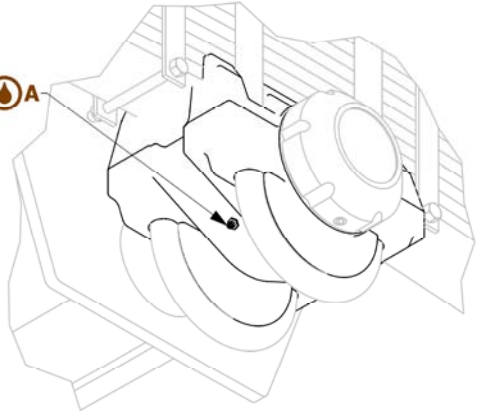

2 – Leaf spring anchoring to the central oscillating support.

After the first 10 km at full load, after the first 500 working hours (or after the first 8500 km travelled), afterwards every 1500 working hours (or every 25000 km travelled).

Check correct housing. Check torque with a torque wrench according to the diagonals of each anchor.

For tightening torques, refer to the previous table.

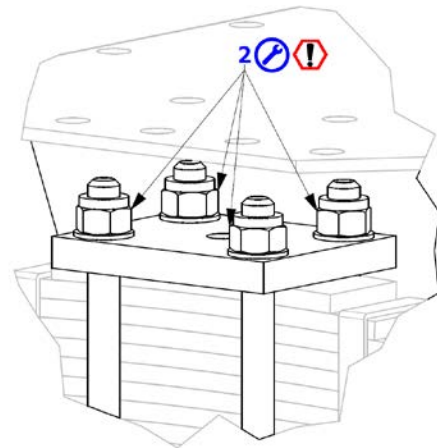



3 - Central support pin.

After the first 10 km at full load, afterwards every 1500 working hours (or every 25000 km travelled). Check threaded pin torque on the central support and relevant stop screw.



If the support rocks in the housing and/or the bushings are worn, contact **ADR - Colaert customer service**.

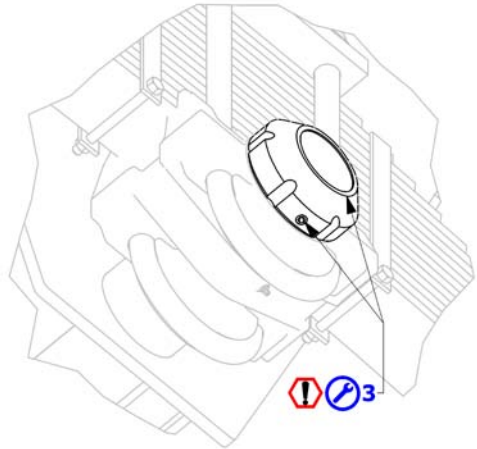

4 – Leaf spring retention straps and leaf spring alignment check.

After the first 10 km at full load, afterwards every 1500 working hours (or every 25000 km travelled). Make sure they are not damaged and the screws are integral and tight. **Check leaf spring alignment.**



In the event of damages, contact **ADR - Colaert customer service**.

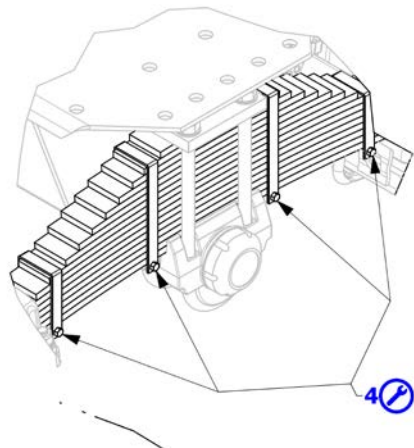



5 – Check rubber plate wear.

Every 3000 working hours (or every 50000 km travelled).

Check plate wear at the ends of the leaf springs as follows:

- unscrew the nuts **I** and remove the washers **II** and clamps **III**;
- when removing the clamps **III** remove the clamp rests **IV**;
- remove the housing case **V**;
- check rubber plate wear **5**.

Reassemble the components, tighten the nuts **I** following the instructions in point 1 – **Axle anchoring to leaf springs**.

If the components are crushed or damaged (cut, cracked) replace them.



Perform this operation with the carriage empty inspecting, dismantling and reassembling one house case at a time.



If replacement is needed, contact **ADR - Colaert customer service**.

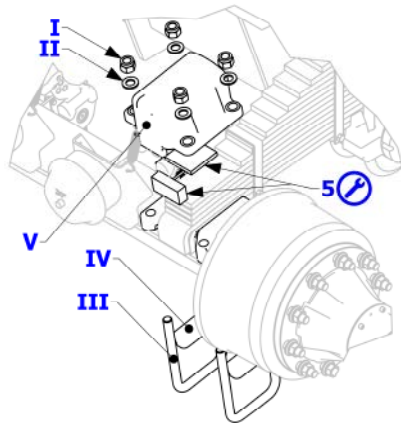

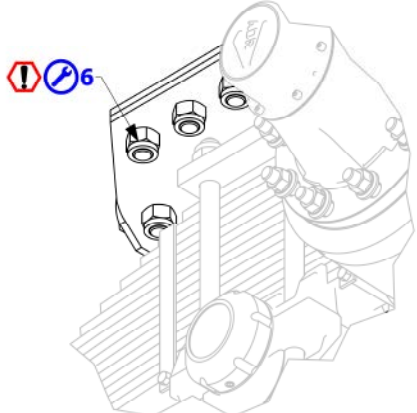
<p> 6 – Check bolt torque.</p> <p>After the first 10 km at full load, after the first 500 working hours (or after the first 8500 km travelled), afterwards every 1500 working hours (or every 25000 km travelled).</p> <p>In versions with bolted coupling to the vehicle chassis, check torque on all support bolts.</p> <p>For tightening torque, refer to the table below.</p>	
---	---















 **Part torque instructions**

screw	wrench	tightening torque (kgm)	tightening torque (Nm)
M 20	30	38 min / 42 max	380 min / 420 max
M 22	34	51 min / 56 max	510 min / 560 max
M 24	36	66 min / 72 max	660 min / 720 max
M 27	41	97 min / 104 max	970 min / 1040 max

4 Tandem and Tridem ADR - COLAERT series K mechanical suspensions

4.1 Tandem and Tridem Series KB and series KE

4.1.1 KB/KE series suspension maintenance work summary table

Tandem and Tridem mechanical suspension lubrication and maintenance table  Lubrication  Maintenance	After the first 10 km of use at full load.	After the first 500 working hours or first 8500 km travelled.	Every 500 working hours or every 8500 km travelled.¹	Every 1500 working hours or every 25000 km travelled.¹
Lubrication with adhesive grease, water repellent and E.P. additive				
A – moderately grease the ends of the leaf springs and relevant sliding housings in the suspension frame (fixed supports and rocker arm)				
Maintenance				
0 – visual inspection of the integrity of all components.				
1 – axle anchoring to leaf spring: check correct housing. Check torque with torque wrench				
2 – threaded pin torque check on rocker arm support.				
3 – threaded pin torque check on axle reaction rods.				
4 – end terminal screw torque check on axle reaction rods.				
5 – non-slip screw torque check on leaf springs				

¹ For each instruction, increase check frequency in the event of heavy duty use.

4.1.2 Tandem and Tridem Series KB and series KE layout

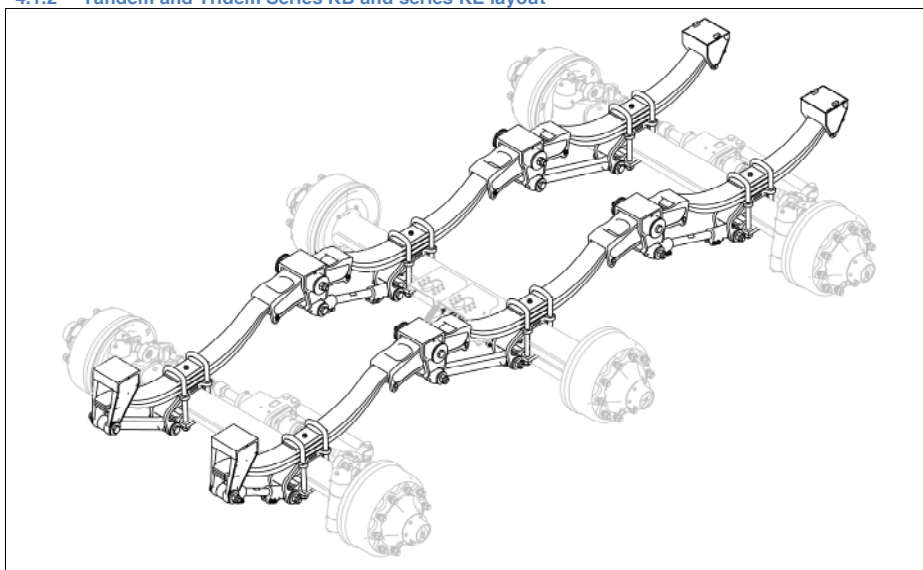

4.1.3 Lubrication and maintenance map

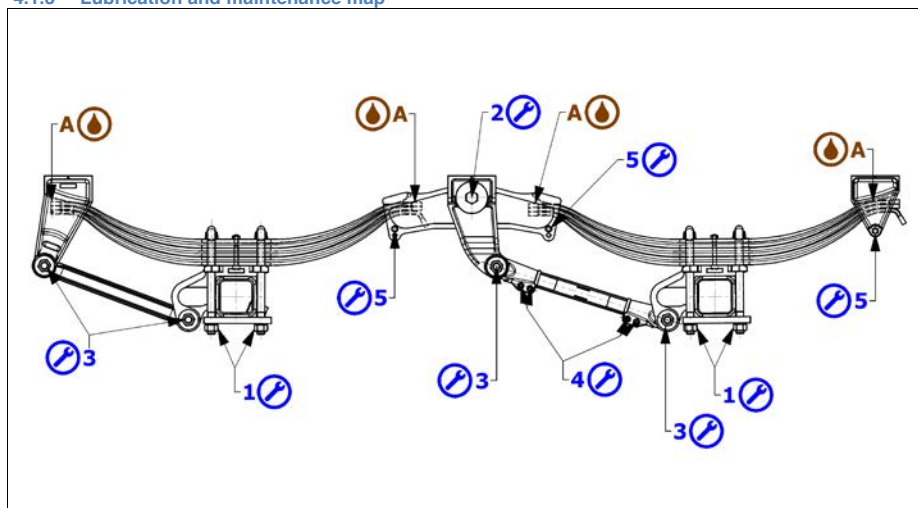



1 - Axle anchoring to leaf spring.

After the first 10 km at full load, after the first 500 working hours (or after the first 8500 km travelled), afterwards every 1500 working hours (or every 25000 km travelled).

Check correct axle anchor housing to the suspension leaf springs and make sure they are correctly tightened.

Check torque with a torque wrench according to the diagonals of each anchor indicated in the illustration.

For torque instructions, refer to the table below.

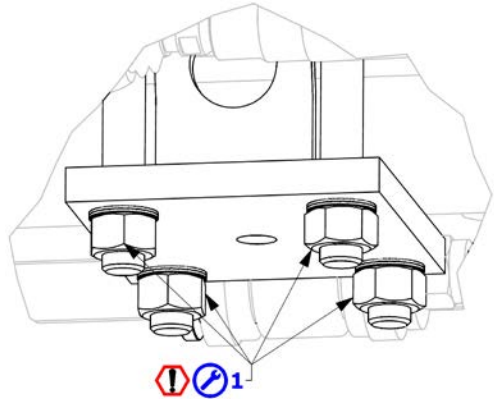

Part torque instructions

U bolt	wrench	tightening torque (kgm)	tightening torque (Nm)
Ø 18	27	23 min / 27 max	230 min / 270 max
Ø 22	34	45 min / 50 max	450 min / 500 max
Ø 24	36	55 min / 60 max	550 min / 600 max
Ø 27	41	60 min / 72 max	600 min / 720 max
Ø 30	46	90 min / 100 max	900 min / 1000 max



2 – Threaded pin torque check on rocker arm support.

Every 1500 working hours (or every 25000 km travelled).

Check threaded pin torque using the torque wrench and referring to the tightening torque indicated in the table below.



A minimum gap of about 4mm should remain visible between the threaded pin head and rocker arm support with this torque value. Should the gap be small or null, replace the joint silent blocks.



Contact **ADR - Colaert customer service** to replace the silent blocks.

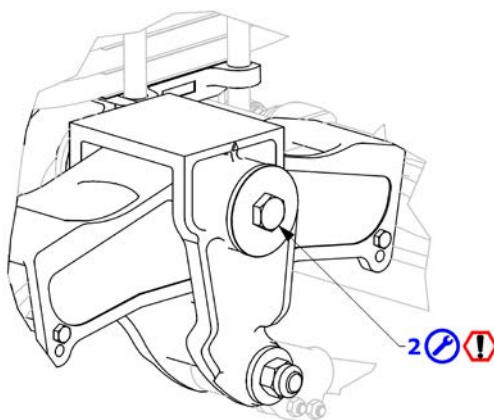
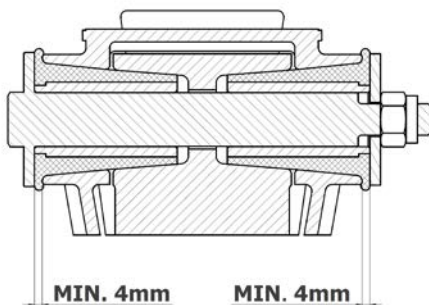

Part torque instructions

id	screw	wrench	Number of pins to be tightened		tightening torque (kgm)	tightening torque (Nm)
			Tandem	Tridem		
2	M 24	36	2	4	27 min / 30 max	270 min / 300 max

 **3 – Threaded pin torque check on axle reaction rods**

After the first 10 km at full load, afterwards every 1500 working hours (or every 25000 km travelled).

Check threaded pin torque on reaction rod ends using the torque wrench and referring to the table at the bottom of the page for tightening torque.



The threaded pin head should remain visible with this torque value. The threaded pin should not be in contact with the support, otherwise the joint silent blocks must be replaced.



Contact **ADR - Colaert customer service** to replace the silent blocks.

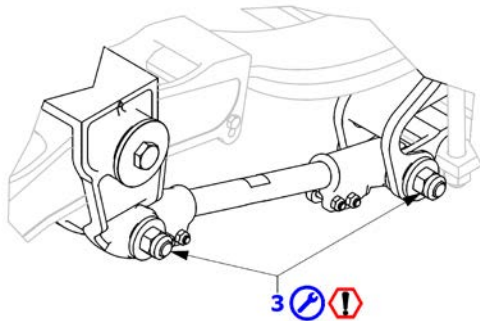



4 – End terminal screw torque check on axle reaction rods

Every 1500 working hours (or every 25000 km travelled).

Check sleeve bolt torque on variable length reaction rod ends using the torque wrench and referring to the tightening torque indicated in the table at the bottom of the page.



Insufficient sleeve torque can alter rod regulation and axle alignment.

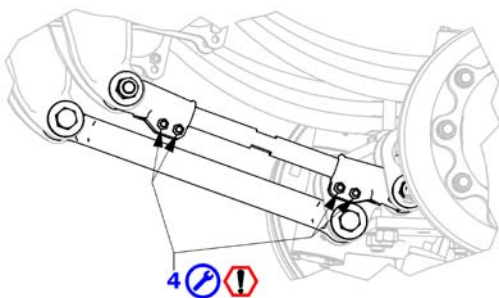

Part torque instructions

id	screw	wrench	tightening torque (kgm)	tightening torque (Nm)
3	M 24	36	10 min / 12 max	100 min / 120 max
4	M 12	19	8 min / 10 max	80 min / 100 max



5 – non-slip screw torque check on leaf springs

After the first 10 km at full load, afterwards every 1500 working hours (or every 25000 km travelled).

Visually check leaf spring non-slip screws. Make sure the nuts are tightened and the screws do not rock in their housings. If the screws are damaged, only replace them after having checked the cause of the damage.



In the event of damages, contact **ADR - Colaert customer service**.

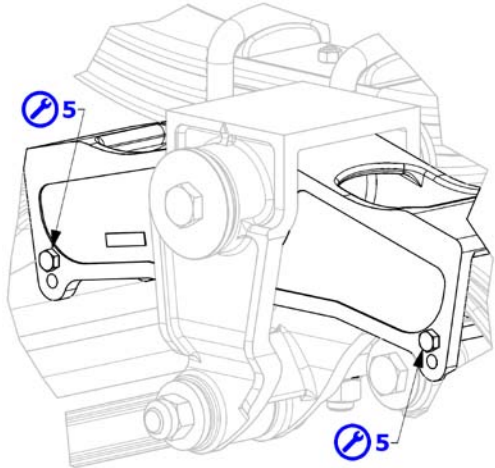

A – Leaf spring end runners





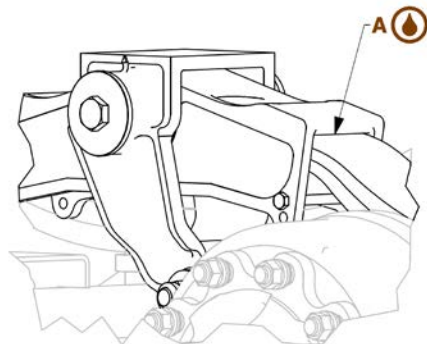
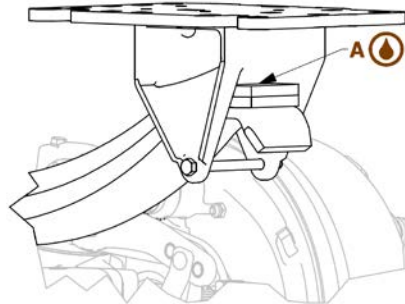











First 10 km at full load, afterwards every 500 working hours (or every 8500 km travelled).

Moderately grease the ends of the leaf springs and relevant sliding housings in the suspension frame (fixed supports and rocker arm) Use grease that has adhesive characteristics, water repellent and with E.P. additive, spreading it on all surfaces with a brush.



4.2 Tandem and Tridem Series KC and series KD

4.2.1 KC/KD series suspension maintenance work summary table

Tandem and Tridem series KC and KD mechanical suspension lubrication and maintenance table  Lubrication  Maintenance	After the first 10 km of use at full load.	After the first 500 working hours or first 8500 km travelled.	Every 500 working hours or every 8500 km travelled. ¹	Every 1500 working hours or every 25000 km travelled. ¹
Lubrication with adhesive grease, water repellent and E.P. additive				
A – moderately grease the ends of the leaf springs and relevant sliding housings in the suspension frame (fixed supports and rocker arm)				
B – Grease rocker arm joint axles.				
Maintenance				
0 – visual inspection of the integrity of all components.				
1 – axle anchoring to leaf spring: check correct housing. Check torque with torque wrench				
2 – threaded pin torque check on rocker arm support.				
3 – check leaf spring anchor threaded pin torque.				
4 – non-slip screw torque check on leaf springs				

¹ For each instruction, increase check frequency in the event of heavy duty use.

4.2.2 Tandem and Tridem Series KC and series KD layout

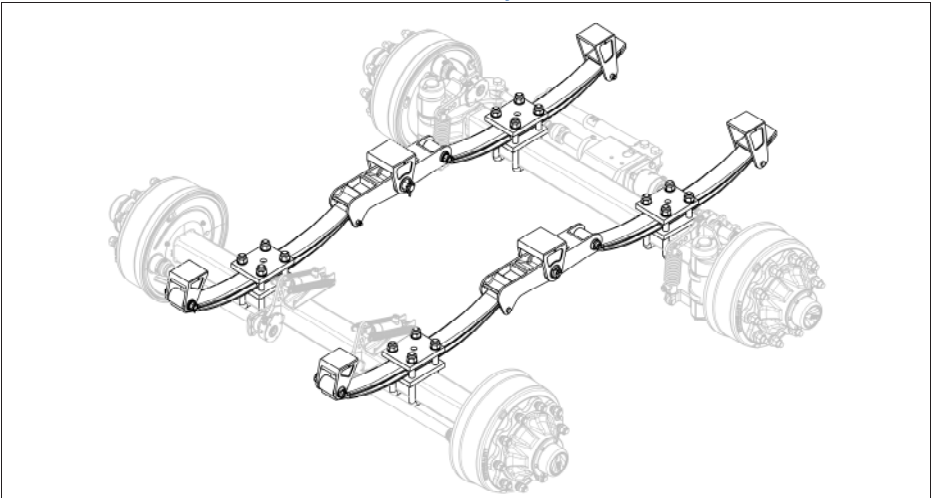

4.2.3 Lubrication and maintenance map

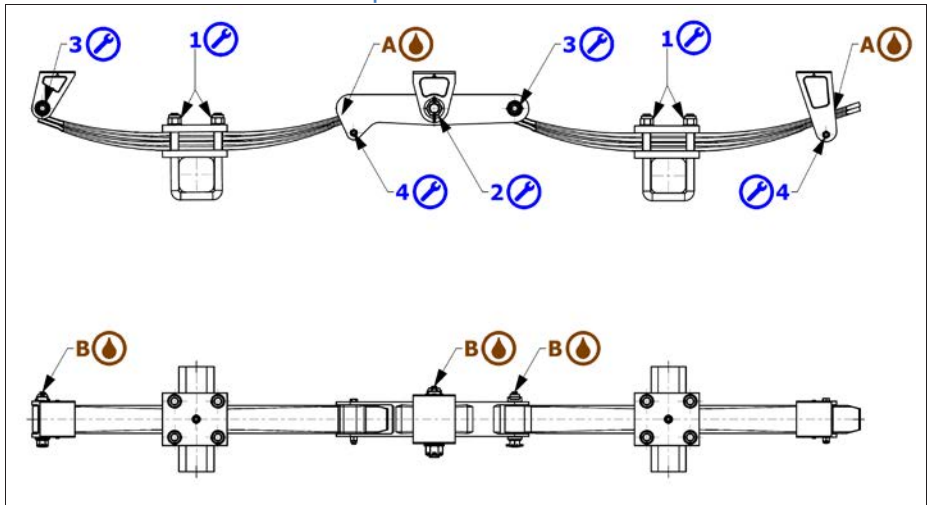



1 - Axle anchoring to leaf spring.

After the first 10 km at full load, after the first 500 working hours (or after the first 8500 km travelled), afterwards every 1500 working hours (or every 25000 km travelled).

Check correct axle anchor housing to the suspension leaf springs and make sure they are correctly tightened.

Check torque with a torque wrench according to the diagonals of each anchor indicated in the illustration.

For tightening torques, refer to the table below.

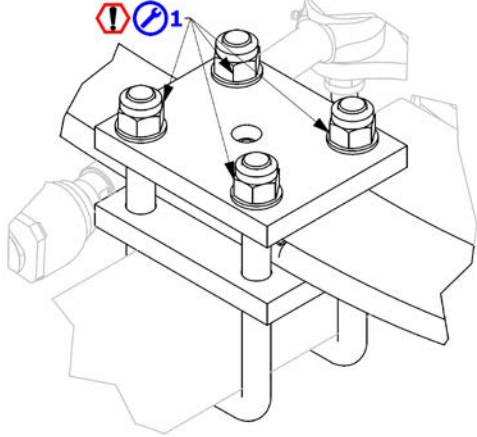

Part torque instructions

U bolt	wrench	tightening torque (kgm)	tightening torque (Nm)
Ø 18	27	23 min / 27 max	230 min / 270 max
Ø 22	34	45 min / 54 max	450 min / 540 max
Ø 24	36	50 min / 60 max	500 min / 600 max
Ø 27	41	60 min / 72 max	600 min / 720 max
Ø 30	46	90 min / 100 max	900 min / 1000 max

2 – Threaded pin torque check on rocker arm support.

Every 1500 working hours (or every 25000 km travelled).

3 – Check leaf spring anchor threaded pin torque.

After the first 10 km at full load, afterwards every 1500 working hours (or every 25000 km travelled).
The pins indicated in the illustration do not have torque instructions with torque wrench.
Make sure the nuts and split pins are integral and the gap between the supports and rocker arm and leaf spring bushings is **under 1mm**.

Otherwise, contact **ADR - Colaert customer service**.

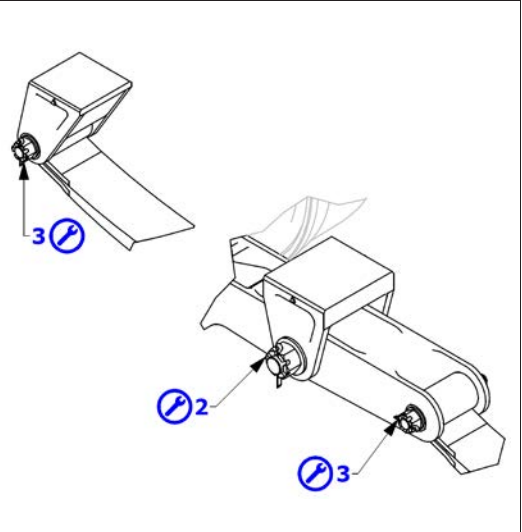

4 – non-slip screw torque check on leaf springs

After the first 10 km at full load, afterwards every 1500 working hours (or every 25000 km travelled).
Visually check leaf spring non-slip screws. Make sure the nuts are tightened and the screws do not rock in their housings. If the screws are damaged, only replace them after having checked the cause of the damage.

In the event of damages, contact **ADR - Colaert customer service**.

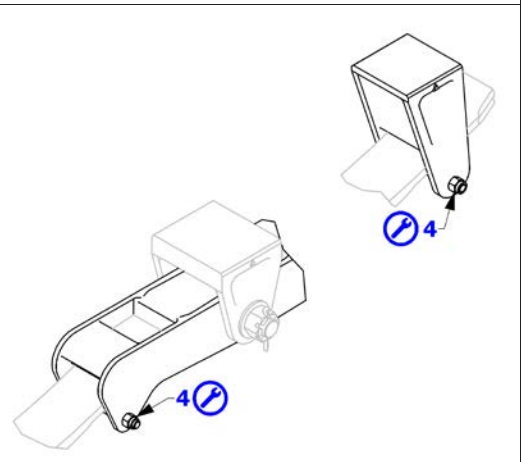



A – Grease leaf spring end runners.

After the first 10 km at full load, afterwards every 500 working hours (or every 8500 km travelled).

Moderately grease the ends of the leaf springs and relevant sliding housings in the suspension frame (fixed supports and rocker arm).

Use grease that has adhesive characteristics, water repellent and with E.P. additive, spreading it on all surfaces with a brush.

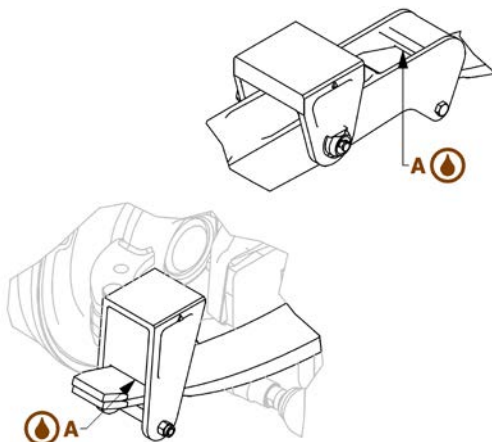

B – Grease rocker arm joint axles.

After the first 10 km at full load, afterwards every 500 working hours (or every 8500 km travelled).





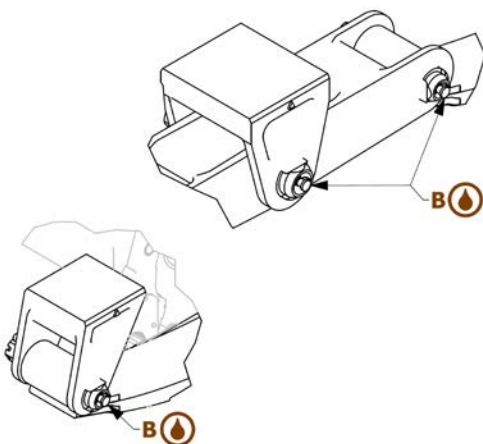



Grease the rocker arm and leaf spring joint pins.

Use grease that has adhesive characteristics, water repellent and with E.P. additive, spreading it on all surfaces with a brush.



4.3 Tandem and Tridem Series KW

4.3.1 KW series suspension maintenance work summary table

Tandem and Tridem mechanical suspension lubrication and maintenance table  Lubrication  Maintenance	After the first 10 km of use at full load.	After the first 500 working hours or first 8500 km travelled.	Every 500 working hours or every 8500 km travelled. ¹	Every 1500 working hours or every 25000 km travelled. ¹
Lubrication with adhesive grease, water repellent and E.P. additive				
A – moderately grease the ends of the leaf springs and relevant sliding housings in the suspension frame (fixed supports and rocker arm)				
Maintenance				
0 – visual inspection of the integrity of all components.				
1 – Axle anchoring to leaf spring: check correct housing. Check torque with torque wrench				
2 – Check central suspension support torque.				
3 – Threaded pin torque check on axle reaction rods.				
4 – End terminal screw torque check on axle reaction rods.				
5 – non-slip screw torque check on leaf springs				

¹ For each instruction, increase check frequency in the event of heavy duty use.
KW-63

4.3.2 KW tandem and tridem layout

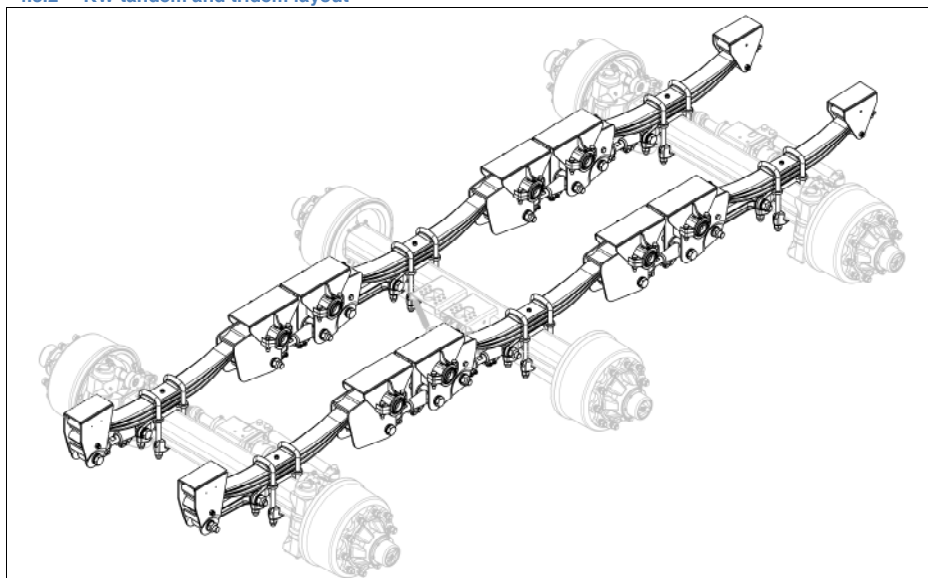

4.3.3 Lubrication and maintenance map

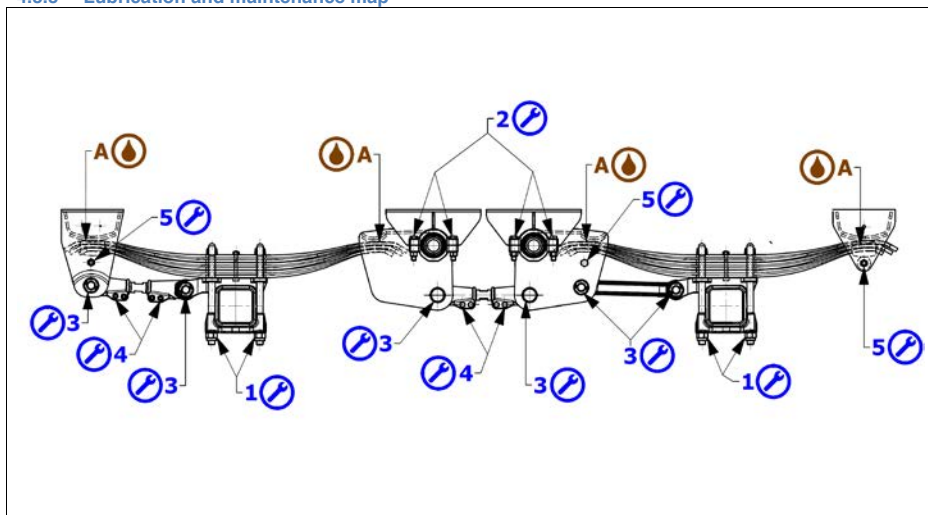

 1 – Axle anchoring to leaf spring: check correct housing.

After the first 10 km at full load, after the first 500 working hours (or after the first 8500 km travelled), afterwards every 1500 working hours (or every 25000 km travelled).

Check correct axle anchor housing to the suspension leaf springs and make sure they are correctly tightened.

Check torque with a torque wrench according to the diagonals of each anchor indicated in the illustration.

For torque instructions, refer to the table below.

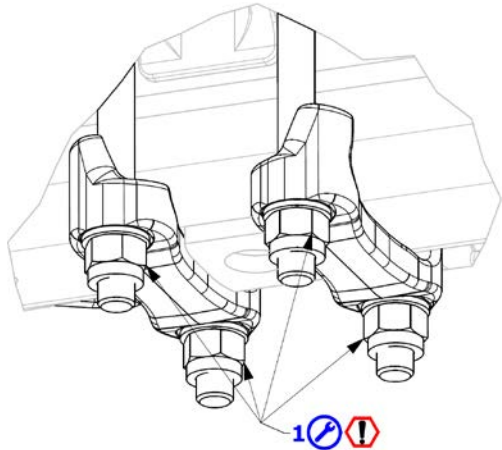

 Part torque instructions

U bolt	wrench	Number of parts to be tightened		tightening torque (kgm)	tightening torque (Nm)
		Tandem	Tridem		
Ø 18	27	16	24	23 min / 27 max	230 min / 270 max
Ø 22	34			45 min / 54 max	450 min / 540 max
Ø 24	36			50 min / 60 max	500 min / 600 max
Ø 27	41			60 min / 72 max	600 min / 720 max
Ø 30	46			90 min / 100 max	900 min / 1000 max

 2 – Check central suspension support torque.

Every 1500 working hours (or every 25000 km travelled).

Check bolt torque in silent block housings using the torque wrench and following the instructions in the table below.

 This torque value must produce a visible compression of the silent block rubber. Should this not occur, replace the joint silent blocks.

 Contact **ADR - Colaert customer service** to replace the silent blocks.

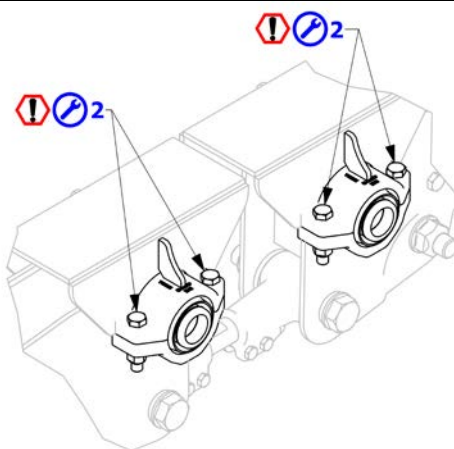

3 – Threaded pin torque check on axle reaction rods

After the first 10 km at full load, afterwards every 1500 working hours (or every 25000 km travelled).

Check threaded pin torque on axle reaction rod ends using the torque wrench following the instructions below.

! The threaded pin head should remain visible and not in contact with the support with this torque value, otherwise the joint silent blocks must be replaced.

Contact **ADR - Colaert customer service** to replace the silent blocks.

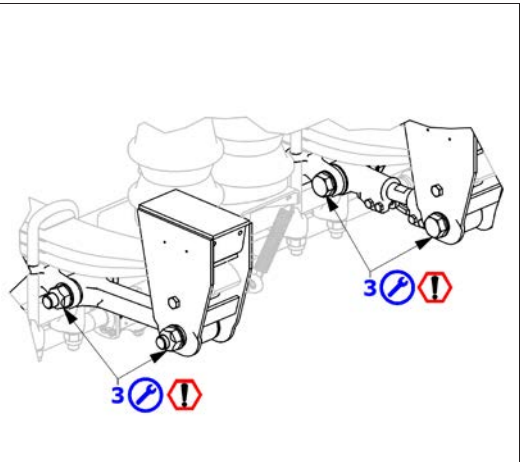

! Part torque instructions

id	screw	wrench	Number of parts to be tightened		tightening torque (kgm)	tightening torque (Nm)
			Tandem	Tridem		
2	M 16	24	16	32	17 min / 20 max	170 min / 200 max
3	M 30	46	12	20	70 min / 80 max	700 min / 800 max

 **4 – End terminal screw torque check on axle reaction rods**

Every 1500 working hours (or every 25000 km travelled).

Check sleeve bolt torque on variable length reaction rod ends using the torque wrench, M12 screws, 19 wrench, 8 - 10 daNm tightening torque.

 **Insufficient sleeve torque can alter rod regulation and axle alignment.**

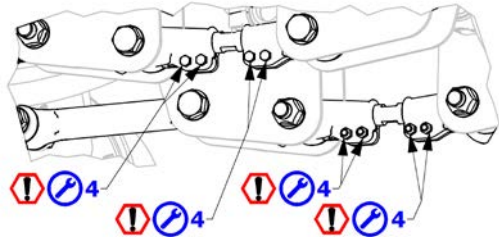

 **5 – Leaf spring non-slip screw torque check.**

After the first 10 km at full load, afterwards every 1500 working hours (or every 25000 km travelled).

Visually check leaf spring non-slip screws. Make sure the nuts are tightened and the screws do not rock in their housings. If the screws are damaged, only replace them after having checked the cause of the damage.

 In the event of damages, contact **ADR - Colaert customer service.**

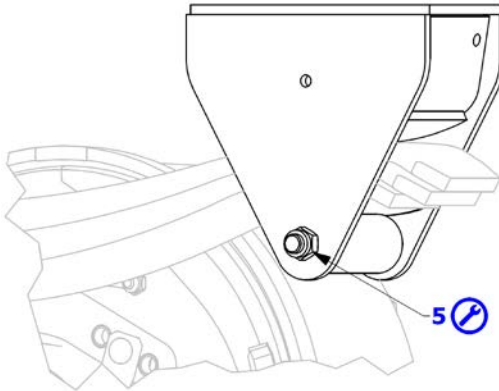

 **Part torque instructions**

id	screw	wrench	Number of parts to be tightened		tightening torque (kgm)	tightening torque (Nm)
			Tandem	Tridem		
4	M 12	19	16	32	8 min / 10 max	80 min / 100 max



A – Leaf spring end runners





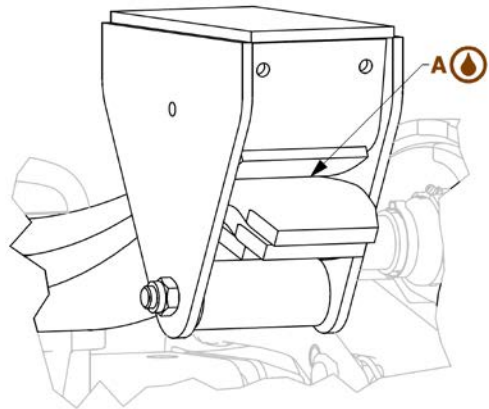
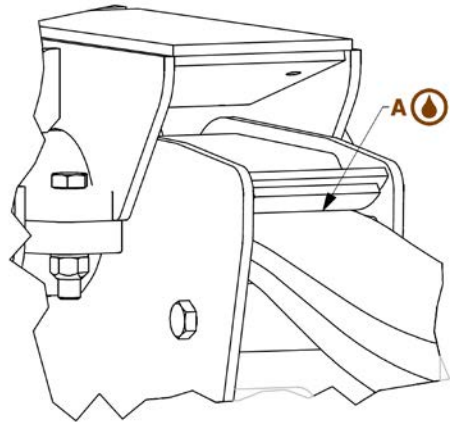















After the first 10 km at full load, afterwards every 500 working hours (or every 8500 km travelled).

Moderately grease the ends of the leaf springs and relevant sliding housings in the suspension frame (fixed supports and rocker arm) Use grease that has adhesive characteristics, water repellent and with E.P. additive, spreading it on all surfaces with a brush.



5 ADR - COLAERT HydrOK series and HydroEVO series oil hydraulic suspensions

5.1 HydrOK series suspension maintenance work summary table

Oil hydraulic suspension lubrication and maintenance table	After the first 10 km at full load.	After the first 500 working hours or first 8500 km travelled.	Every 500 working hours or every 8500 km travelled. ¹	Every 1500 working hours or every 25000 km travelled. ¹
 Lubrication  Maintenance				
Lubrication with special ADR Lithogrease 3 grease				
A - upper and lower suspension cylinder joints				
Maintenance				
0 – visual inspection of the integrity of all components.				
1 – check correct parabolic arm anchoring housing and torque				
2 – check parabolic arm articulation nut torque to frame				
3 – check suspension cylinder fastening and check for any oil leaks				
4 – check cross beam compensation rod fastening				
5 - check frame fastening bolt torque				

¹ For each instruction, increase check frequency in the event of heavy duty use.

5.2 Oil hydraulic suspensions with KFRAME ADR - COLEART HydrOK series rods

5.2.1 Oil hydraulic suspension layout with KFRAME compensation rods

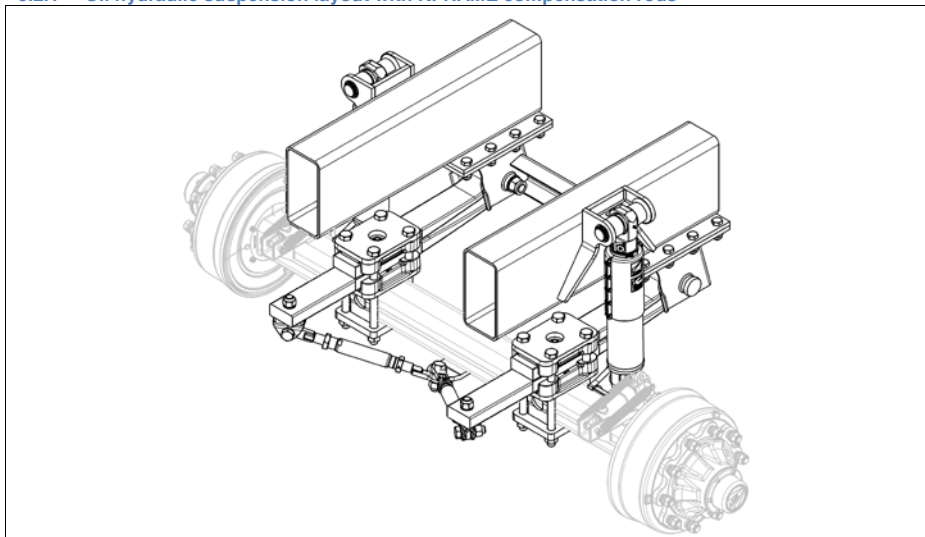

5.2.2 Lubrication and maintenance point map

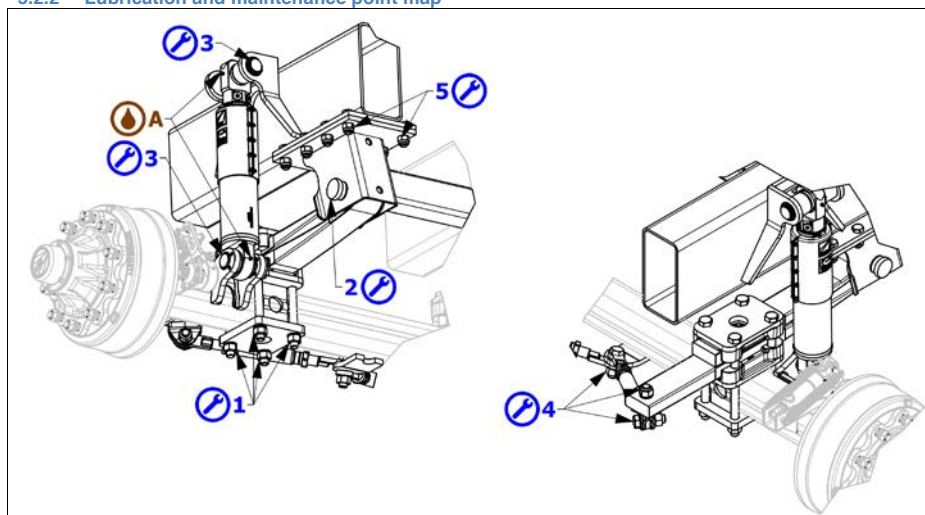

5.3 ADR - COLAERT HydrOK series oil hydraulic suspensions

5.3.1 HydrOK oil hydraulic suspension layout

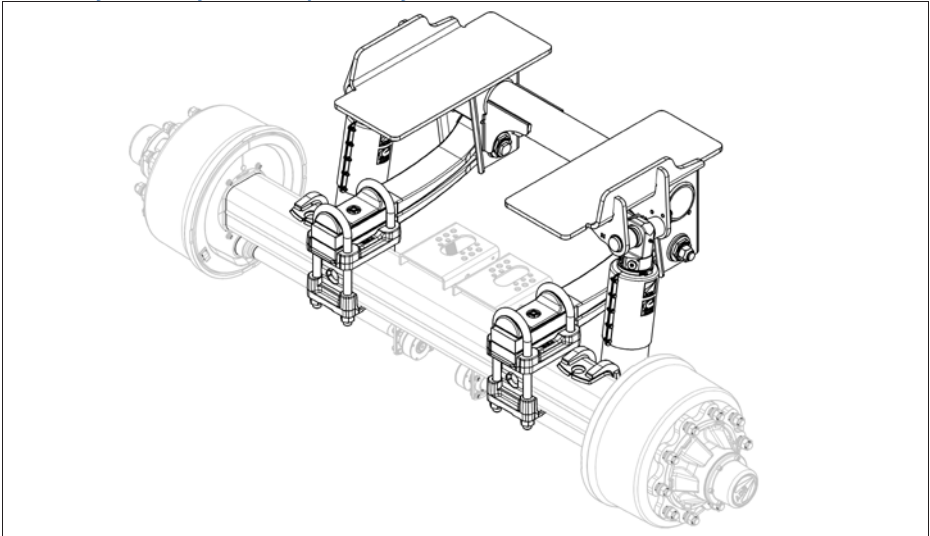

5.3.2 Lubrication and maintenance point map

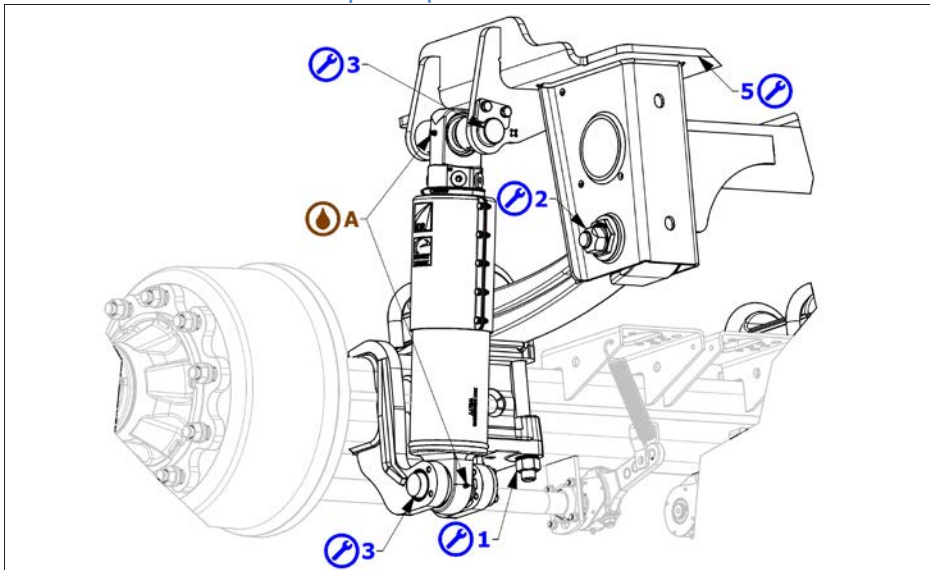

Hydro



1 – Check correct parabolic arm anchoring housing.

After the first 10 km at full load, after the first 500 working hours (or 8500 km travelled), later every 1500 working hours (or 25000 km travelled).

Make sure suspension parabolic arm anchors are correctly tightened.

Check torque with torque wrench according to the diagonals of each anchor indicated in the illustration.

1-A: Parabolic arm oil hydraulic suspensions with rigid stabiliser frame (KFRAME).

1-B: Suspension with yoke U-BOLT.

For tightening torque, see the table below.

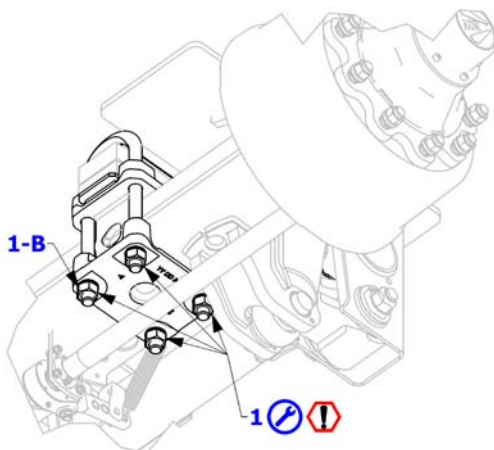
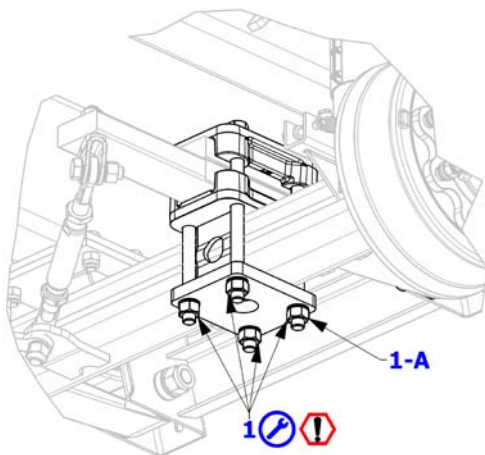

Part torque instructions

id	Thread	Wrench	tightening torque (kgm)	tightening torque (Nm)
1-A	M 24	36	80 min / 85 max	800 min / 850 max
1-B	M 24	36	60 min / 71 max	605 min / 715 max

2 – Check parabolic arm articulation nut torque to frame

After the first 10 km at full load, after the first 500 working hours (or 8500 km travelled), later every 1500 working hours (or 25000 km travelled).

Check, moderately moving the vehicle forward and back or forcing the pins with a lever, that parabolic arm articulation pins do not rock.

Check torque on the nuts indicated in the illustration using a torque wrench, following the instructions in the table at the bottom of the page.

For regulation systems with eccentric bushing (2-B), if necessary check axle alignment following regulation instructions IS-228. For further information visit www.adraxles.com or contact **ADR - Colaert customer service**.

Incorrect suspension arm anchoring could serious jeopardise driving safety and produce abnormal tyre wear.

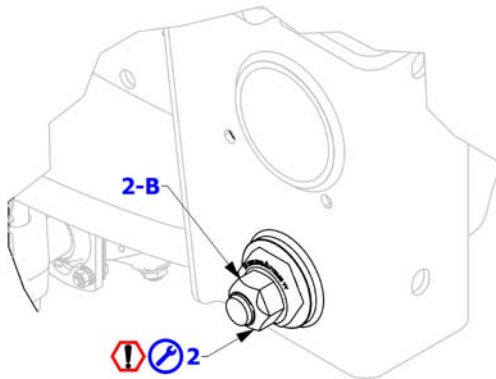
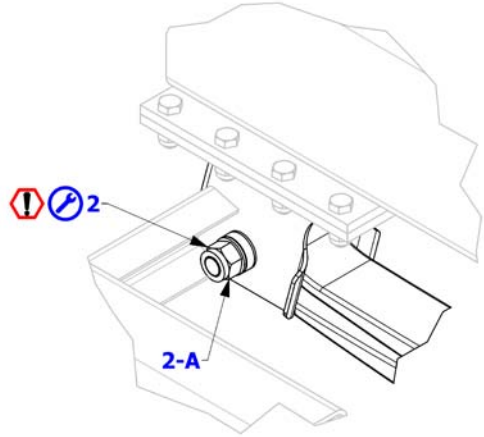

Hydro

Part torque instructions

id	screw	wrench	Number of parts to be tightened	tightening torque (kgm)	tightening torque (Nm)
2-A	M 30	46	2	84 min / 99 max	840 min / 990 max
2-B	M 27	41	2	55 min / 60 max	550 min / 1000 max



3 – Check suspension cylinder fastening and check for any oil leaks.

After the first 10 km at full load, after the first 500 working hours (or 8500 km travelled), later every 1500 working hours (or 25000 km travelled).

Make sure suspension oil hydraulic cylinder anchors do not rock and are correctly secured.

Check torque on screws 3-B (if included) and 3-AB indicated in the illustration using a torque wrench, following the instructions in the table at the bottom of the page.



A - Suspension cylinder joint terminal lubrication.

After the first 10 km at full load, later every 500 working hours (or 8500 km travelled).

Lubricate in the illustrated points with **ADR Lithogrease 3** grease.

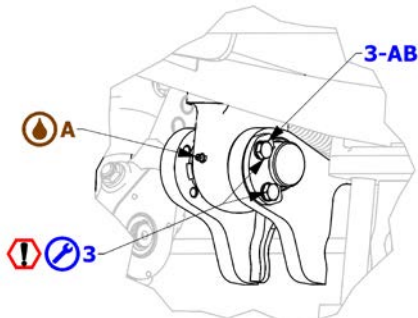
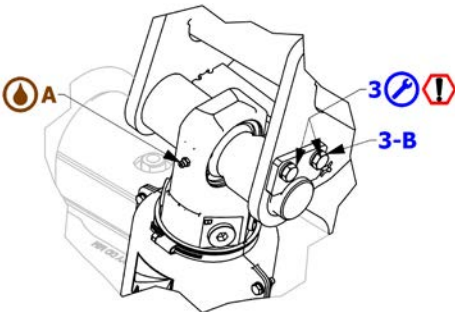
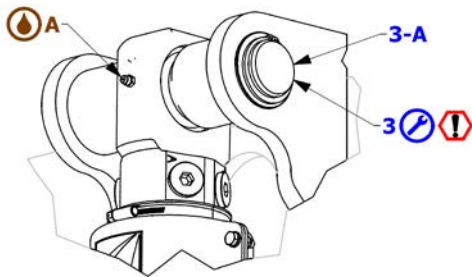

Part torque instructions

id	screw	wrench	Number of parts to be tightened	tightening torque (kgm)	tightening torque (Nm)
3-B	M 10	16	2	4 min / 6 max	40 min / 60 max
3-AB	M 10	16	2	4 min / 6 max	40 min / 60 max



4 – Check cross beam compensation rod fastening.

After the first 10 km at full load, after the first 500 working hours (or 8500 km travelled), later every 1500 working hours (or 25000 km travelled).

In versions with compensation rods, make sure rod end screws are correctly tightened. Check torque as indicated in the following table with a torque wrench.

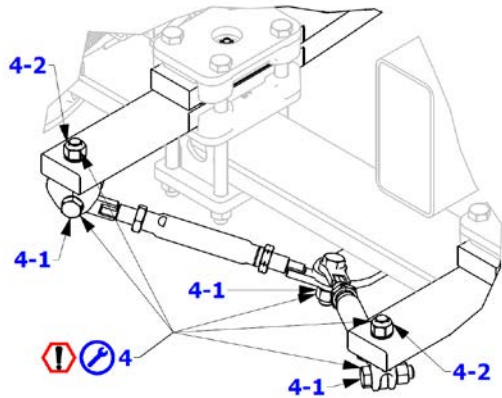

Part torque instructions

id	screw	wrench	Number of parts to be tightened	tightening torque (kgm)	tightening torque (Nm)
4-1	M 24	36	3	65 min / 69 max	650 min / 690 max
4-2	M 24	36	2	32 min / 36 max	320 min / 360 max



5 - Check bolt torque.

After the first 10 km at full load, after the first 500 working hours (or 8500 km travelled), later every 1500 working hours (or 25000 km travelled).

In versions with bolted coupling to vehicle chassis, check all support bolt torque.

For tightening torque see the table below.

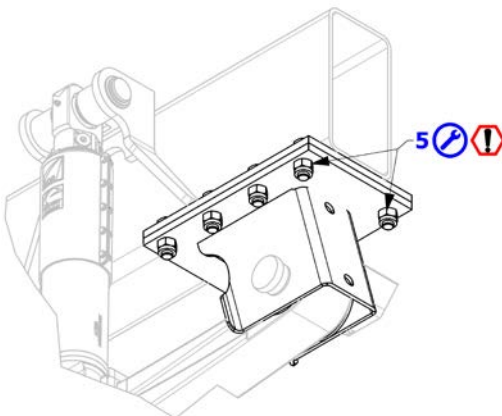



















Part torque instructions

screw	wrench	tightening torque (kgm)	tightening torque (Nm)
M 20	30	38 min / 42 max	380 min / 420 max
M 22	34	51 min / 56 max	510 min / 560 max
M 24	36	66 min / 72 max	660 min / 720 max
M 27	41	97 min / 104 max	970 min / 1040 max

5.4 ADR - COLAERT HydroEVO series independent arm hydraulic suspensions

5.4.1 HydroEVO series suspension maintenance work summary table

Oil hydraulic suspension lubrication and maintenance table  Lubrication  Maintenance	After the first 10 km at full load.	After the first 500 working hours or first 8500 km travelled.	Every 500 working hours or every 8500 km travelled. ¹	Every 1500 working hours or every 25000 km travelled. ¹
Lubrication with special ADR Lithogrease 3 grease				
A - Upper and lower suspension cylinder joints				
B - Independent arm articulation pins				
Maintenance				
0 – Visual inspection of the integrity of all components.				
1 – check pin stop plate screw torque				
2 – check oscillating arm articulation stop screw and nut torque				
3 – check suspension cylinder fastening and check for any oil leaks				
4 – check frame fastening bolt torque				

¹ For each instruction, increase check frequency in the event of heavy duty use.

ADR - Colaert independent arm hydraulic suspension layout

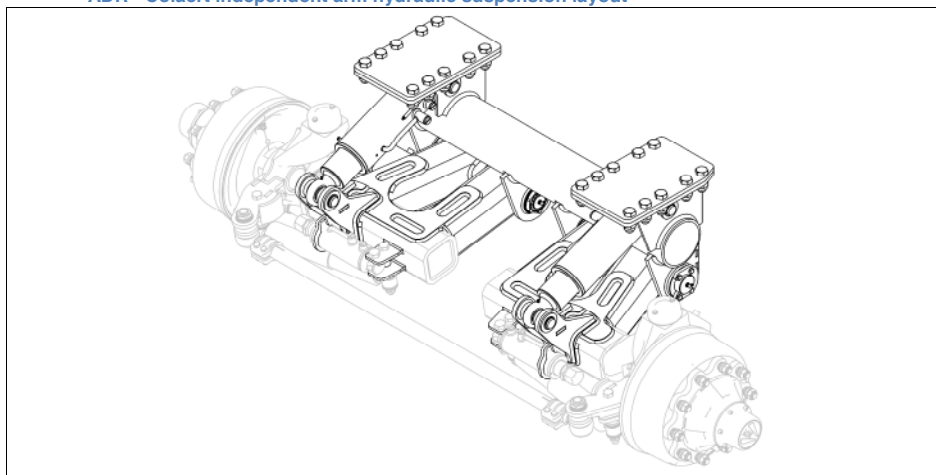

5.4.2 Lubrication and maintenance point map

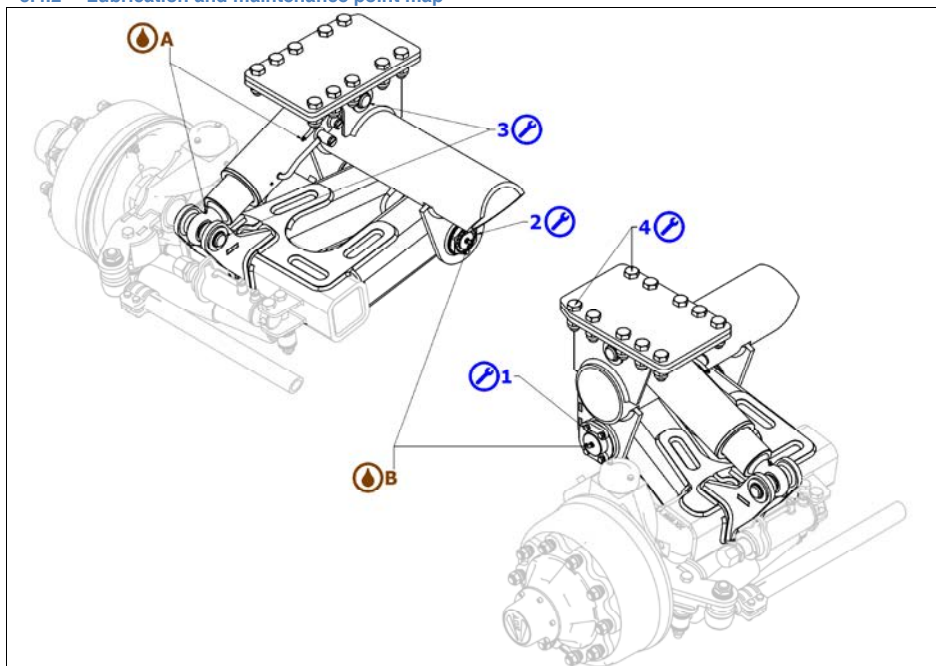

 1 – Check pin stop plate screw torque

After the first 10 km at full load, after the first 500 working hours (or 8500 km travelled), later every 1500 working hours (or 25000 km travelled).

Make sure the 4 fastening screw 1-2 on the stop plate 1-1 are correctly tightened. Check torque with torque wrench.

For tightening torque, see the table in the next page.

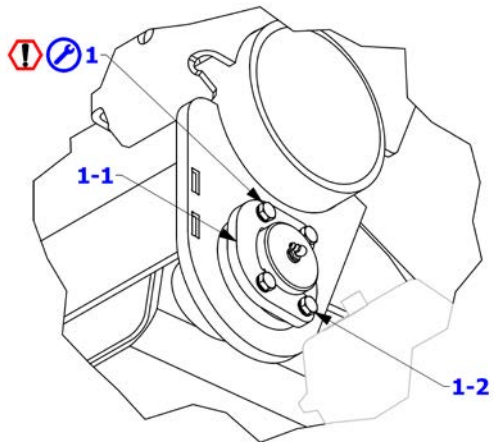



2 – Check oscillating arm articulation nut torque.

After the first 10 km at full load, after the first 500 working hours (or 8500 km travelled), later every 1500 working hours (or 25000 km travelled).

Check nut 2-2 and screw 2-4 torque.
Procedure:

- Remove the threaded nut stop screws 2-4.
- Remove the rack 2-3
- Check nut 2-2 torque with torque wrench.
- Reassemble the rack 2-3 and secure it to the nut with screws 2-4, check torque using torque wrench.

Tightening torque is provided in the table below.

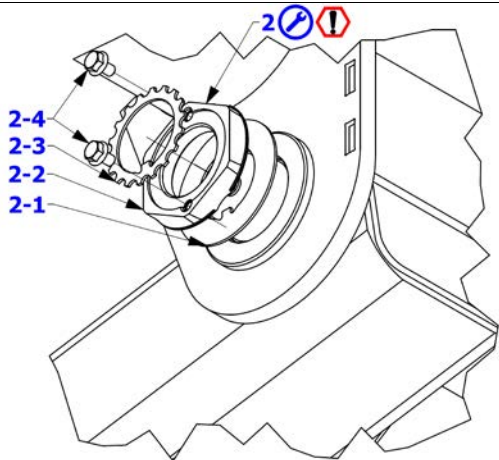

Part torque instructions

id	thread	wrench	tightening torque (kgm)	tightening torque (Nm)
1-2	M 10	16	4.5 min / 5.5 max	45 min / 55 max
2-2	M 55	85	30 min / 35 max	300 min / 350 max
2-4	M 8	13	4 min / 5 max	40 min / 50 max



3 – Check suspension cylinder fastening and check for any oil leaks.

After the first 10 km at full load, after the first 500 working hours (or 8500 km travelled), later every 1500 working hours (or 25000 km travelled).

Make sure suspension oil hydraulic cylinder anchors do not rock and are correctly secured.



A - Suspension cylinder joint terminal lubrication.

After the first 10 km at full load, later every 200 working hours.

Lubricate using the specific greasers in the illustrated points. Use **ADR Lithogrease 3** grease

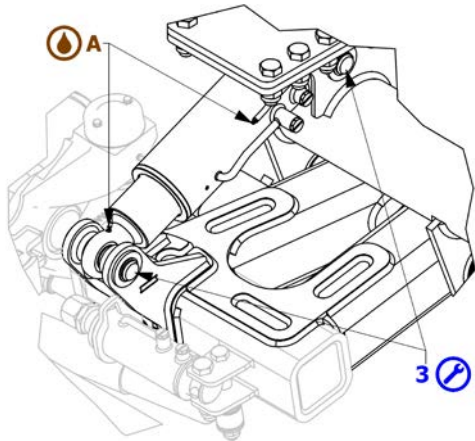

4 - Check bolt torque.

After the first 10 km at full load, after the first 500 working hours (or 8500 km travelled), later every 1500 working hours (or 25000 km travelled).

In versions with bolted coupling to vehicle chassis. Check all support bolt torque.

For tightening torque see the table below.

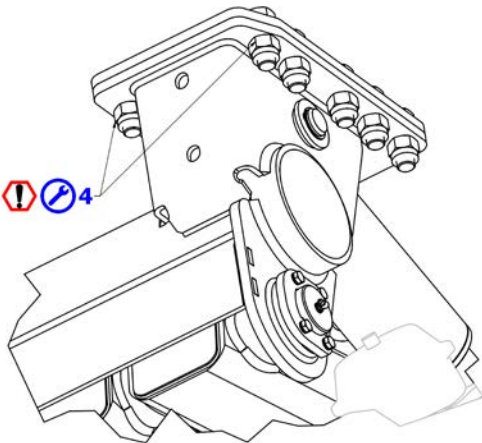

Part torque instructions

id	thread	wrench	tightening torque (kgm)	tightening torque (Nm)
4	M 24	36	67 min / 82 max	670 min / 820 max



B - Independent arm articulation pin lubrication

After the first 10 km at full load, later every 500 working hours (or 8500 km travelled).

Lubricate using the specific greasers B-1 and B-2 in the illustrated points. Use **ADR Lithgrease 3** grease

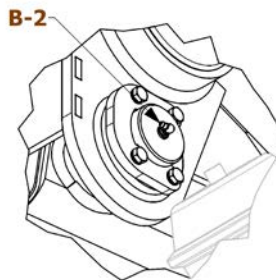
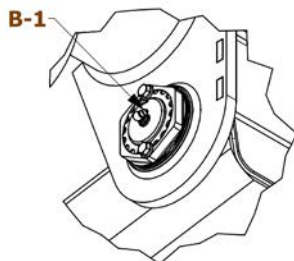
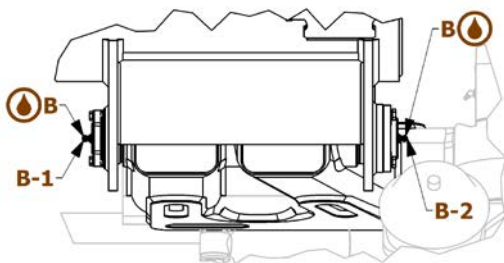



moving innovation

**A.D.R. S.p.A.**

Via Antonio Maria Ceriani, 96 - 21040 Uboldo (VA) ITALY
Tel. +39 02 961711 - Fax +39 02 96171420
info@adraxles.com - www.adraxles.com

**COLAERT ESSIEUX**

Route nationale 11/bis 59189 Steenbecque FRANCE
Tel. +33 328438550 - Fax +33 328436863
commercial@colaertessieux.fr - www.colaert-essieux.fr

**ADR Polska**

Ul Bieszczadzka, 5 - 38540 Zagorz POLAND
Tel. +48 1346 89333 - Fax +48 1346 89368
atw@atwsystem.pl - www.atwsystem.pl

**ADR UK - TYREMART AGRICULTURAL LTD**

Main Road, Long Bennington, Newark, Notts, NG235DJ GREAT BRITAIN
Tel. +44 1400 283820 - Fax +44 1400 283137
accounting@tyremartagri.co.uk - www.tyremartagri.co.uk

**ADRGEPLASMETAL sa**

Pol. Malpica c/ J n°1 - 50.057 Zaragoza ESPAÑA
Tel. +34 976 465 254 - Fax. +34 976 571 132
info@adrgeplasmetal.com - www.geplasmetal.com

**C.L.M. S.r.l.**

Zona industriale, 26 - 33049 S.Pietro al Natisone (UD) ITALY
Tel. +39 432 727851 - Fax +39 432 727852
www.clmwheels.com

**Qingdao ADR Axles Manufacturing Co., Ltd.**

No. 1616 Lingang Industrial Park, Jiaonan City, Qingdao City,
Shandong Province - Post Code 266400 CHINA
Tel. +86 532 8619 6636 - Fax +86 532 86196501 - info@adrsystem.cn

**ADR EIXOS BRASIL - Riberáo Preto - SP**

Rua Antonio Fernandes Figueroa, 1807, Parque Industrial Lagoinha - Riberáo Preto São Paulo cep
14.085-280 BRASIL - Tel. +55 16 39653946 - Fax +55 16 36173079

ADR EIXOS BRASIL - Itupeva - SP

Rod. Vice Prefeito Hermenegildo Tonolli, 2777 - Galpao 3 - 13295-000 - Itupeva / SP - BRASIL Tel.
+55 11 4496 3990 - Fax +55 11 4496 4170 - adrbrasil@adreixos.com.br - www.adraxles.com/pt

**OMEGA Drives Inc.**

7A - 845 Lagimodiere Blvd. Winnipeg, Manitoba R2J 3M2 CANADA
Tel. +1 204 453 2477 - Fax +1 204 453 2478
info@omegadrives.com - www.omegadrives.com

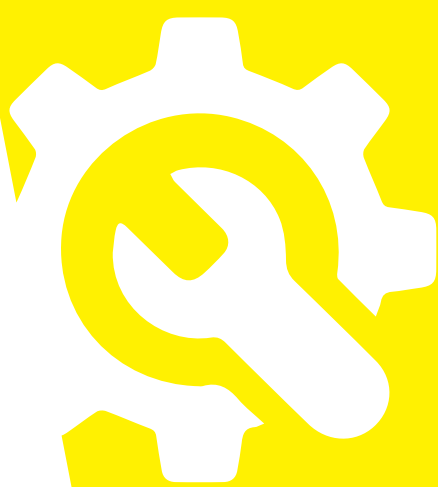

www.adraxles.com
group



www.adraxles.com